

**CUSTOMER:**Interforward

**NO.:**2022112104

**DISTRIBUTOR:**  
(PE48AA1)

**APPROVE SHEET**  
[ Compliance with RoHS ]

**PRODUCT:** DC BRUSHLESS FAN

**USER P/N.:** \_\_\_\_\_

**Parts No.:** UF1238B2UR1135066RBH

**Printed model number on the stick:**UF1238B2URBH

(SIGNATURE)

**JAMICON GROUP**

**KAIMEI ELECTRONIC CORP.**

**Tel: +886-2-26981010**

**Fax: +886-2-26980386**



APPROVED	CHECKED	DRAWN
張裕銳	鄧龍軍	郝文姣

### Records of Revision

Part No.	UF1238B2UR1135066RBH	Customer:	Interforward
Rev	Revision Description		Date
A0	First edition		2022/11/21

## 1. MECHANICAL:

1-01	Dimension	Dimension of fan shall be shown in the outline styling drawing attached.
1-02	Motor	Four-pole motor.
1-03	Frame	Plastic material UL 94V-0(P.B.T).
1-04	Impeller	Plastic material UL 94V-0(P.B.T).
1-05	Free drop shock	In minute package condition, the fan should withstand each one drop of three faces from 30cm distance height onto 10 mm thickness of wooden board.

## 2.ELECTRICAL:25°C/65%RH

2-01	Rated current	Rated current shall be measured after 30 minutes continuous rotation at rated voltage.
2-02	Start voltage	The voltage that enable to start the fan by sudden switch on.
2-03	Rated Speed	Rated speed shall be measured after 10 minutes continuous rotation at rated voltage.
2-04	Input Power	Input power shall be measured after 10 minutes continuous rotation at rated voltage.
2-05	Lock Current	Locked current shall be measured Within one minute at rotor locked, after 30 minutes continuous rotation at rated voltage in clear air.
2-06	Insulation resistance	More than 10M ohm at 500 V.D.C between lead and housing.
2-07	Dielectric strength	Measured 5 mA(max) trip current at 700 V.A.C for 3 sec. between lead and housing.
2-08	Locked motor protection	Designed to meet UL, CUL and TUV.

**DO NOT use power or ground PWM to control the fan speed.If the fan speed needs to be adjusted,please contact JAMICON to customize the product design for your application.**

### 3.CHARACTERISTICS:

3-01	Air Flow & Static Pressure	The air flow data and static pressures should be determined in accordance with AMCA standard or DIN 24163 specification in a double- chamber testing with intake-side measurement.
3-02	Noise level	The measurement of noise level is carried out with reference to DIN 45635 in an echoic chamber with the microphone positioned 1 M from the air intake. Testing fan shall be hung in clean air.

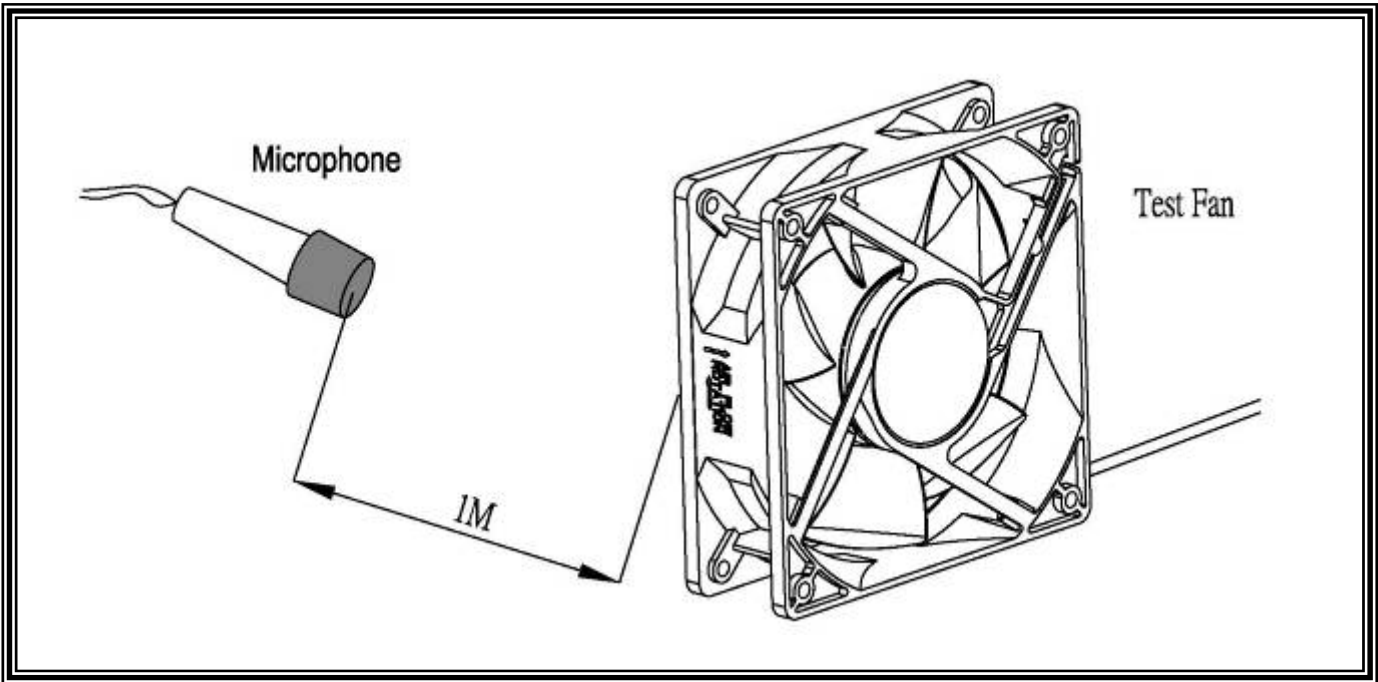

### 4.ENVIRONMENTAL:

4-01	Operating temperature	-10°C to 70°C (ordinary humidity)
4-02	Storage Temperature	-40°C to 70°C (ordinary humidity)
4-03	Humidity	After 96 hrs, 95% RH 40±2°C per MIL-STD-202F method 103B, Humidity test , The measured data of insulation resistance & dielectric strength should meet the specification listed in attach.
4-04	Thermal Shock	After thermal shock test per MIL-STD-202F method 107D, Condition D, The measured data of insulation resistance & dielectric strength should the specification.

**5.DATA-SHEET:****PARTS NO.: UF1238B2UR1135066RBH****SAP NO.: U1238B2UR1135066BH****5-1. SPECIFICATION:**

NO.	ITEM	SPECIFICATION	UNIT	CONDITION
5-1-01	Dimension	120*120*38	mm	-----
5-1-02	Bearing	Dual Ball	-----	-----
5-1-03	Rated Voltage	24.0	VDC	-----
5-1-04	Operating Voltage	12.0 ~ 27.6	VDC	MAX. 27.6V
5-1-05	Start Voltage	12.0	VDC	On/off test max.
5-1-06	Speed	5200	R.P.M	±10%,At rated Voltage
5-1-07	Input Current	1.20	Amp	At rated Voltage
5-1-08	Input Power	28.80	Watt	At rated Voltage
5-1-09	Nominal Current	1.5	Amp	At rated Voltage
5-1-10	Air Flow	199.7	CFM	At 0 static Pressure of rated speed
5-1-11	Static Pressure	1.052	inchH <sub>2</sub> O	At 0 air flow of rated speed
5-1-12	Noise	60.3	dBA	At rated speed
5-1-13	Life Expectancy(L10)	70,000	Hours	At 40°C (Bearing)
5-1-14	Motor protection	Electronic protected		
5-1-15	Polarity Protection	YES	-----	-----
5-1-16	Auto Restart	YES	-----	-----
5-1-17	Speed Signal Output	NO	-----	-----
5-1-18	Alarm Signal Output	NO	-----	-----
5-1-19	Rotation direction	From the label side	-----	Clockwise
5-1-20	Weight	-----	Gram	Per each piece
5-1-21	Safety Certificate	-----	-----	-----

**5-2. LEAD WIRE:**

NO.	ITEM	SPECIFICATION			
5-2-01	AWG NO. & Authorize	24AWG , UL1007			
5-2-02	Color	—	+		
		Black	Red		
5-2-03	Line Length	255 ± 10mm			
5-2-04	Connector	Notes as: Pitch:3.96mm Housing:Molex 5239-02 compatible parts.			
5-2-05	Tube	NO			

### JAMICON FAN PERFORMANCE CURVES

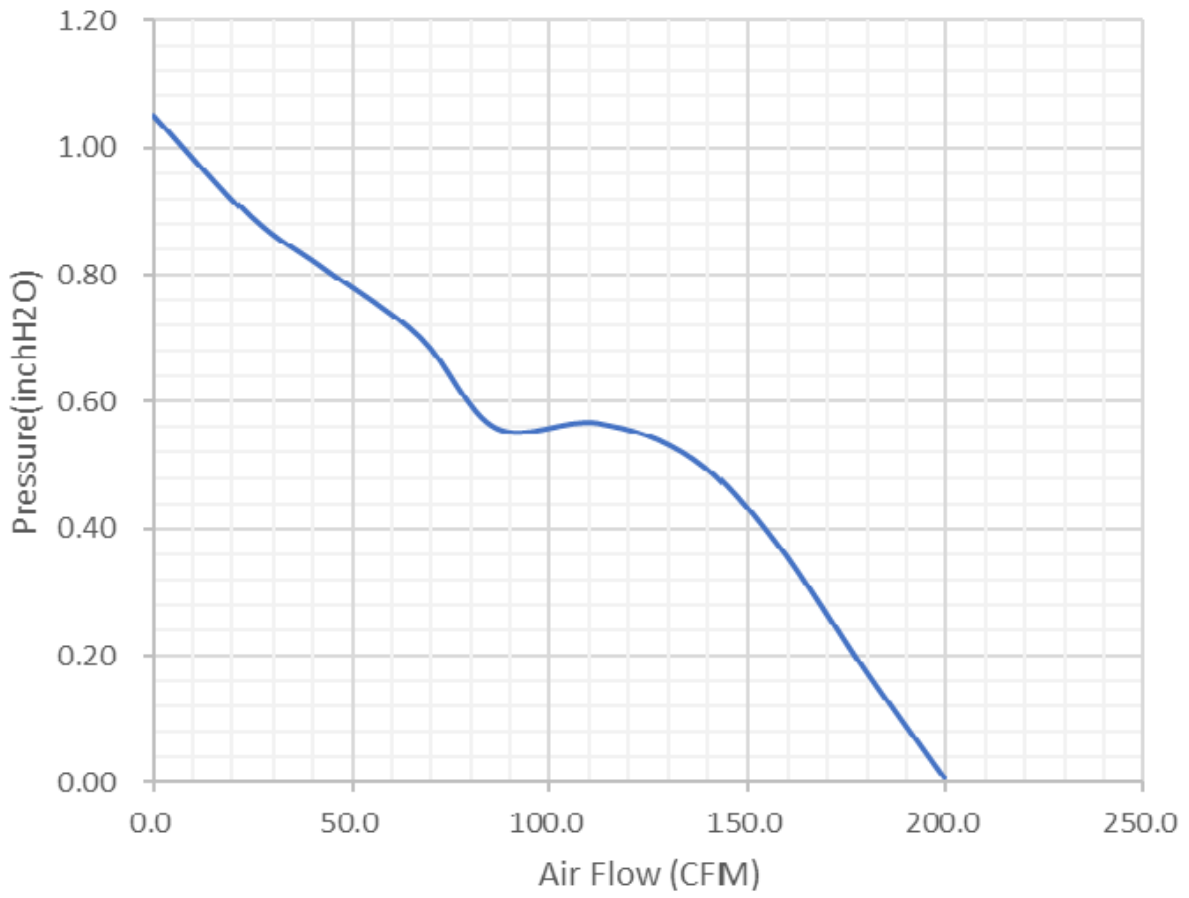

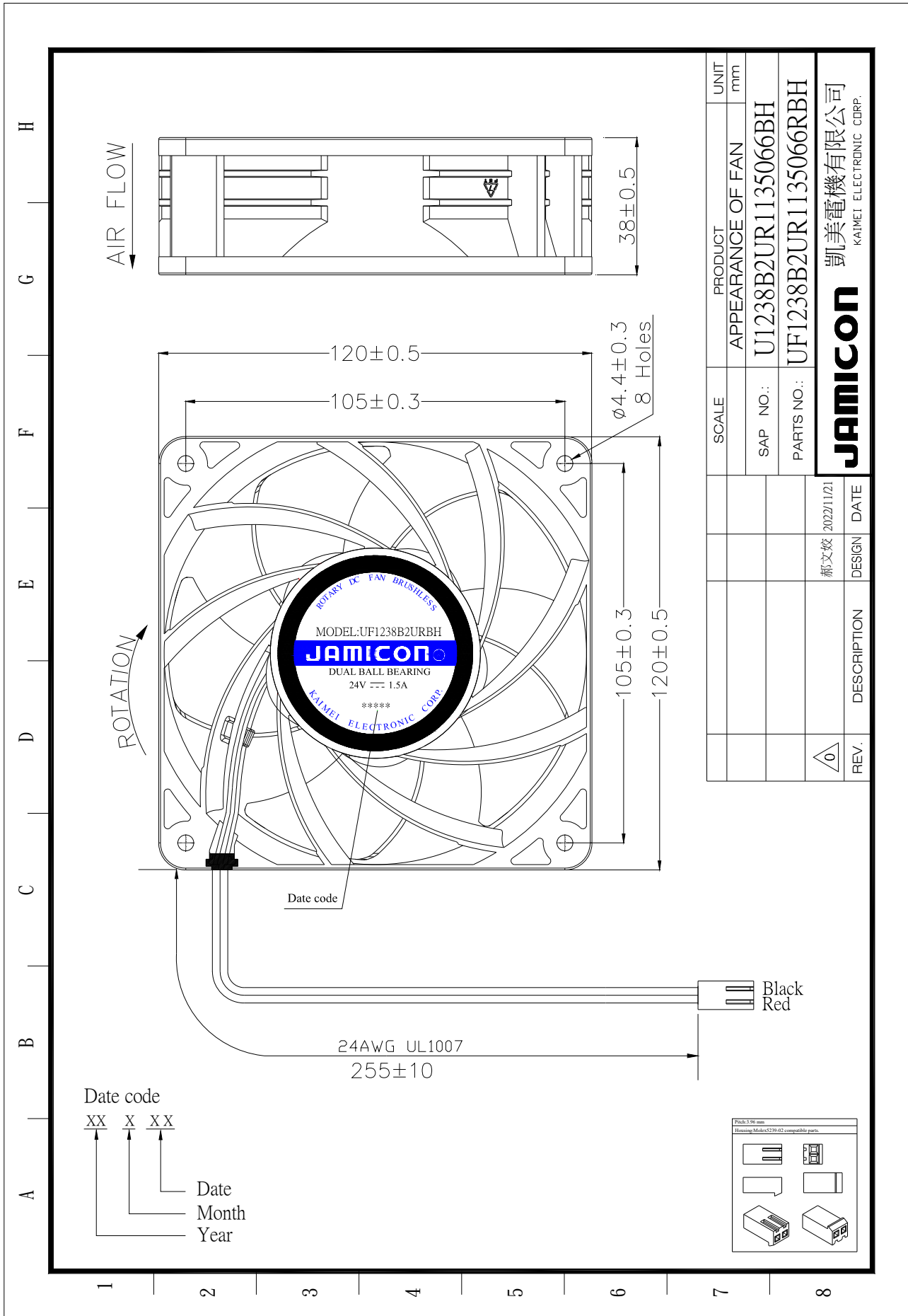

SCALE	PRODUCT APPEARANCE OF FAN	UNIT
	U1238B2UR1135066BH	mm
SAP NO.:	UF1238B2UR1135066RBH	
PARTS NO.:		
REV.	DESCRIPTION	DESIGN
0		
REV.	DATE	DATE
	郝文姣	2022/11/21

**JAMICON**  
 凯美电机有限公司  
 KAMEI ELECTRONIC CORP.

# Auto-restart

Fan motor speed

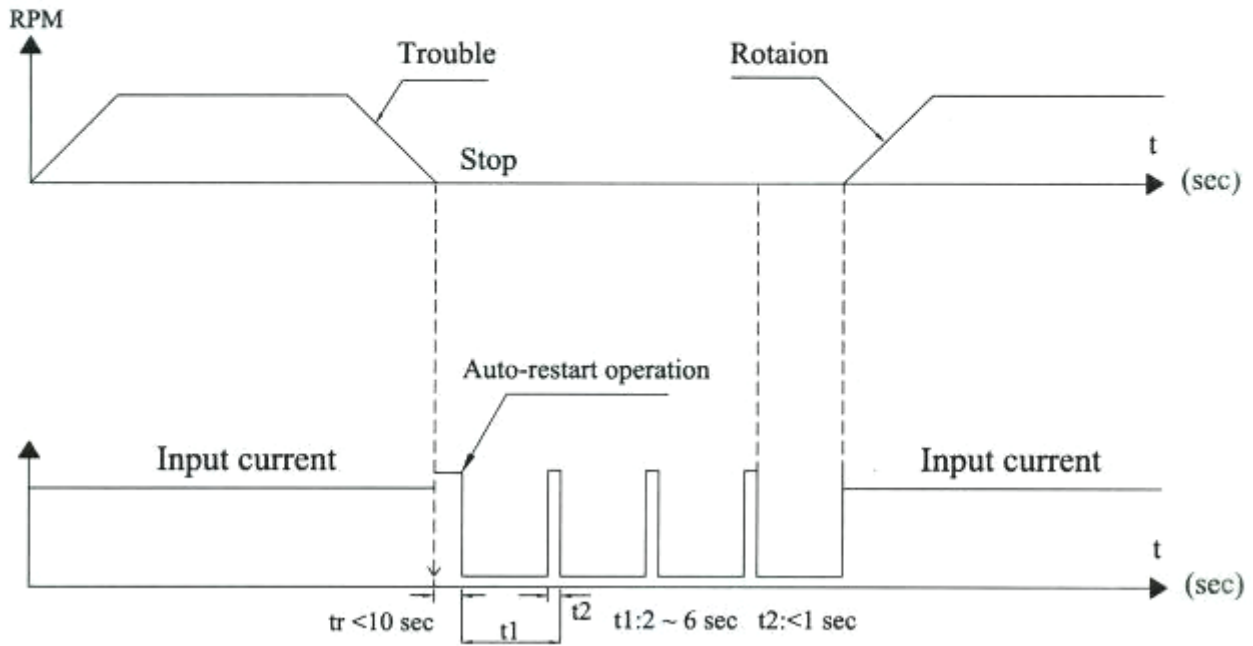

Notes:

1. JAMICON will not guarantee this product if it is used in conditions other than the parameters outlined in this specifications.  
如果在其他條件下使用本產品，凱美電機將不保證，而不是本規範中概述的參數。
2. Except where specifically stated, all tests are carried out at relative (ambient) temperature and humidity conditions of 25°C, 65%RH. The test value is only for fan performance itself.  
除非特別說明，所有試驗均在 25°C、65%相對濕度的相對（環境）溫度和濕度條件下進行。測試值僅用於風扇性能本身。
3. It is very important to establish the correct polarity before connecting the fan to the power source, Positive (+) and Negative (-). Damage may be cause by connecting with reverse polarity. (For the fan with polarity protection function, Jamicon still recommends not to connect the polarity reversely as much as possible.) 在將風扇連接到電源（正極（+）和負極（-）之前，確定正確的極性非常重要。使用相反極性連接可能導致損壞。（對於具有極性保護功能的風扇，Jamicon 仍建議盡可能不要將極性接反）
4. Please be cautious when mounting the fan. Incorrect mounting of fans may cause excess resonance, vibration and subsequent noise.  
安裝風扇時請小心。風扇安裝不正確可能導致過度共振、振動和隨後的噪音。
5. Please do not touch the impeller and never carry the fan the lead wires. The bearings and the lead wires may be damaged. Additionally, static electricity may damage the internal circuits of the fan  
請不要觸摸葉輪，也不要攜帶風扇引線，軸承和導線可能損壞。此外，靜電可能會損壞風扇的內部電路
6. Not all series fans are provided with the lock rotor protection feature. Damage or failure will result from operating fans without this feature, if the impeller for the fan is in any way hindered or impaired.  
並非所有系列風機都具有鎖定轉子保護功能。如果風扇的葉輪受到任何阻礙或損壞，則在沒有此功能的情況下運行風扇將導致損壞或故障

- 7、 DO NOT use power or ground PWM to control the fan speed. If the fan speed needs to be adjusted, please contact JAMICON to customize the product design for you application.  
不要使用電源或接地 PWM 控制風扇轉速。如果需要調整風扇轉速，請聯繫凱美電機為您的應用定制產品設計。
- 8、 Always ensure that fans are stored according to the storage temperatures specified. Do not store in a high humidity environment. If the fans are stored for more than 6 months, we recommend functional testing before using.  
始終確保按照規定的存儲溫度存儲風扇，不要存放在高濕度環境中，如果風扇存放超過 6 個月，我們建議在使用前進行功能測試。
- 9、 Avoid operating JAMICON products in environments where poisonous or corrosive elements are present (organic, silicon, cyanogens, formal in phenol, H<sub>2</sub>S, SO<sub>2</sub>, NO<sub>2</sub>, Cl<sub>2</sub>, etc)  
避免在存在有毒或腐蝕性元素（有機、矽、氰、苯酚中的甲醛、H<sub>2</sub>S、SO<sub>2</sub>、NO<sub>2</sub>、Cl<sub>2</sub> 等）的環境中操作凱美電機產品
- 10、 When using multiple fans in parallel, connect an 'over 4.7μF 'capacitor externally to the fan to prevent abnormality resulting from unstable power.  
當並聯使用多個風扇時，在風扇外部連接一個“超過 4.7μF”的電容器，以防止電源不穩定導致異常。
- 11、 The “Life Expectancy” of this fan has not been evaluated for use in combination with any end application. Therefore, the life expectancy Test reports (L10 and MTTF report) that relate to this fan are only for reference.  
該風扇的“預期壽命”尚未評估是否與任何終端應用結合使用。因此，與該風機相關的預期壽命測試報告（L10 和 MTTF 報告）僅供參考。
- 12、 Except as pertains to some special designs , there is no guarantee that the products will be free from any such safety problems or failures as caused by the introduction of powder , droplets of water or encroachment of insect into the hub .  
除某些特殊設計外，不保證產品不會出現因粉末、水滴或昆蟲侵入輪轂而引起的任何安全問題或故障。