

LISTEN.
THINK.
SOLVE.SM

CompactBlock LDX I/O

TECHNICAL DATA



1790D SERIES



	Preface	
	About This Publication	5
	Additional Resources	5
	Chapter 1	
CompactBlock LDX I/O for the DeviceNet Network	Introduction	7
	Features.	10
	Benefits.	10
	Typical Configuration	11
	System Compatibility	11
	CompactBlock LDX I/O	
	Family Module Communication	11
	Polled	11
	Cyclic	12
	Change-of-state	12
	Software and EDS File Requirements.	12
	Status Indicators.	13
	Module/Network Status Indicators - All Base Modules	14
	I/O Status Indicators - Digital Base and Expansion Modules	14
	I/O Status Indicators - Analog Base Modules	15
	I/O Status Indicators - Analog Base Modules	15
	I/O Status Indicators - RTD and Thermocouple Base Modules	16
	Power Supply Requirements	16
	Mounting	16
	CompactBlock LDX I/O Accessories and DeviceNet Cables	18
	Chapter 2	
DeviceNet Digital and Analog D-Shell Blocks	General Specifications	19
	Module Information.	20
	24V dc 16 Sourcing Output Base and Expansion Modules (1790D-0B16 and 1790-0B16X)	21
	24V dc 16 Sinking Output Base and Expansion Modules (1790D-0V16 and 1790-0V16X)	22
	6-relay Output Base Module (1790D-0W6)	23
	8-relay Output Expansion Module - 1790-0W8X	24
	24V dc 16 Universal Input Base and Expansion Modules (1790D-16BV0 and 1790-16BV0X)	25
	24V dc 8 Universal Input/8 Sourcing Output Base and Expansion Modules (1790D-8BV8B and 1790-8BV8BX)	27
	24V dc 8 Universal Input/8 Sinking Output Base and Expansion Modules (1790D-8BV8V and 1790-8BV8VX)	29
	4-channel Input RTD Base Module (1790D-4R0)	31
	4-channel Input Thermocouple Base Module (1790D-4T0)	33
	2-channel Analog Current Output Module (1790D-N0C2)	35
	2-channel Analog Voltage Output Module (1790D-N0V2)	36

DeviceNet Digital and Analog Terminal Blocks

4-channel Analog Current Input Module (1790D-N4C0)	37
4-channel Analog Voltage Input Module (1790D-N4V0)	39
Chapter 3	
General Specifications	41
Module Information.	42
120V ac, 6 Output Base Module (1790D-T0A6)	43
120V ac, 8 Output Base Module (1790-T0A8X)	44
24V dc 16 Sourcing Output Base and Expansion Modules (1790D-T0B16 and 1790-T0B16X)	45
24V dc 32 Sourcing Output Base Module (1790D-T0B32).	46
24V dc 16 Sinking Output Base and Expansion Modules (1790D-T0V16 and 1790-T0V16X)	48
24V dc 32 Sinking Output Base Module (1790D-T0V32).	49
6 Relay Output Base Module (1790D-T0W6)	51
8 Relay Output Expansion Module (1790-T0W8X)	52
24V dc 16 Universal Input Base and Expansion Modules (1790D-T16BV0 and 1790-T16BV0X)	53
24V dc 32 Universal Input Base Module (1790D-T32BV0)	55
120V ac 8 Input Base and Expansion Modules (1790D-T8A0 and 1790-T8A0X)	57
24V dc 8 Universal Input/8 Sourcing Output Base and Expansion Modules (1790D-T8BV8B and 1790-T8BV8BX)	59
24V dc 16 Universal Input/16 Sourcing Output Base Module (1790D-T16BV16B)	61
24V dc 8 Universal Input/8 Sinking Output Base and Expansion Modules (1790D-T8BV8V and 1790-T8BV8VX)	63
24V dc 16 Universal Input/16 Sinking Output Base Module (1790D-T16BV16V)	65
4 Channel Input RTD Base Module (1790D-T4R0)	67
4 Channel Input Thermocouple Base Module (1790D-T4T0)	69
2 Channel Analog Current Output Module (1790D-TN0C2).	71
2 Channel Analog Voltage Output Module (1790D-TN0V2).	72
4 Channel Analog Current Input Module (1790D-TN4C0)	73
4 Channel Analog Voltage Input Module (1790D-TN4V0)	75

About This Publication

This publication provides detailed technical information on the CompactBlock LDX I/O for DeviceNet modules.

Additional Resources

The publications listed in this table contain more information on CompactBlock LDX I/O modules as well as the DeviceNet network and its products.

Related Publications for CompactBlock LDX I/O Modules

Pub. Title	Pub. Number
IP20 Block I/O Selection Guide	1790-SG001
1790 CompactBlock LDX I/O Product Profile	1790-PP002
CompactBlock LDX Analog Modules User Manual	1790-UM001
CompactBlock LDX I/O for DeviceNet Technical Data	1790D-TD001
CompactBlock LDX I/O for PROFIBUS DP Technical Data	1790P-TD001
CompactBlock LDX RTD/Resistance Input Module User Manual	1790-UM002
CompactBlock LDX I/O Thermocouple Modules User Manual	1790-UM003
DeviceNet Analog Base D-Shell CompactBlock LDX I/O Installation Instructions	1790-IN004
DeviceNet Analog Base Terminal Block CompactBlock LDX I/O Installation Instructions	1790-IN002
DeviceNet Digital Base D-Shell Block CompactBlock LDX I/O Installation Instructions	1790-IN007
DeviceNet Digital Base D-shell Block CompactBlock LDX I/O Series B Installation Instructions	1790-IN013
DeviceNet Digital Base Terminal Block CompactBlock LDX I/O Series A Installation Instructions	1790-IN006
DeviceNet Digital Base Terminal Block CompactBlock LDX I/O Series B Installation Instructions	1790-IN012
Digital Expansion Terminal Block CompactBlock LDX I/O Installation Instructions	1790-IN005
Profibus DP Digital Base Terminal Block CompactBlock LDX I/O Installation Instructions	1790-IN009
DeviceNet Media Design and Installation Guide	DNET-UM072

You can view or download publications at <http://literature.rockwellautomation.com>. To order paper copies of technical documentation, contact your local Rockwell Automation distributor or sales representative.

Notes:

CompactBlock LDX I/O for the DeviceNet Network

Introduction

The CompactBlock I/O product family offers a cost-effective I/O product line for industrial automation.

CompactBlock LDX I/O uses the leading device-level communication network, the DeviceNet network, to translate simple messages from the controller to the plant floor. It is especially suitable where low cost and confined space are coupled with reduced environmental requirements.

The DeviceNet network uses advanced network technology, producer and consumer communication, to increase network function and throughput. Visit our website at <http://www.ab.com/networks> for producer and consumer technology information and updates.

CompactBlock LDX I/O Modules

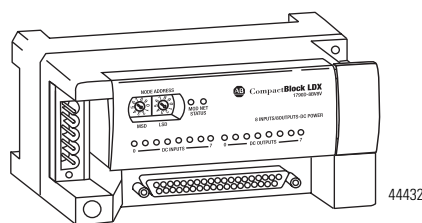

16-bit Base Module with D-shell Connector

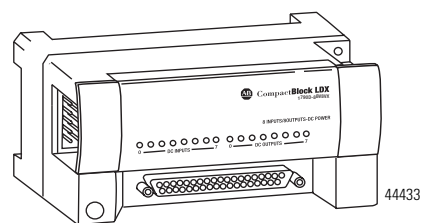

16-bit Expansion Module with D-shell Connector

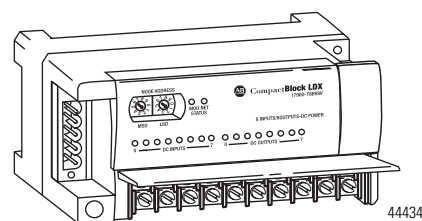

16-bit Base Module with Screw Terminations

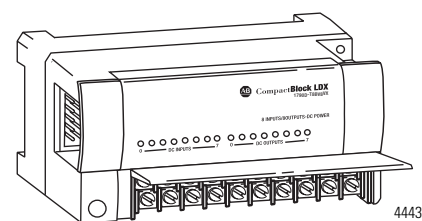

16-bit Expansion Module with Screw Terminations

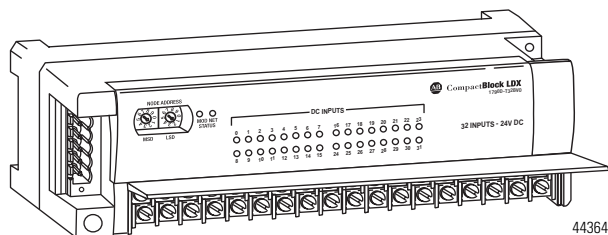

32-bit Base Module with Screw Terminations

The table shows what CompactBlock LDX I/O for DeviceNet base and expansion modules are available with D-shell connectors.

CompactBlock LDX I/O Modules with D-shell Connectors

D-shell Modules	Description
1790D-0B16	24V dc, 16 sourcing output base module
1790-0B16X	24V dc, 16 sourcing output expansion module
1790D-0V16	24V dc, 16 sinking output base module
1790-0V16X	24V dc, 16 sinking output expansion module
1790D-0W6	6-relay output base module
1790-0W8X	8-relay output expansion module
1790D-16BV0	24V dc, 16 universal input base module
1790-16BV0X	24V dc, 16 universal input expansion module
1790D-8BV8B	24V dc, 8 universal input/8 sourcing output base module
1790-8BV8BX	24V dc, 8 universal input/8 sourcing output expansion module
1790D-8BV8V	24V dc, 8 universal input/8 sinking output base module
1790-8BV8VX	24V dc, 8 universal input/8 sinking output expansion module
1790D-4R0	4-channel input RTD base module
1790D-4T0	4-channel input thermocouple base module
1790D-N0C2	2-channel analog output current module
1790D-N0V2	2-channel analog output voltage module
1790D-N4C0	4-channel analog input current module
1790D-N4V0	4-channel analog input voltage module

The table shows what CompactBlock LDX I/O for DeviceNet base and expansion modules are available with screw terminations (terminal blocks).

CompactBlock LDX I/O Modules with Screw Terminations

Terminal Blocks	Description
1790D-T0A6	120V ac, 6 output base module
1790-T0A8X	120V ac, 8 output expansion module
1790D-T0B16	24V dc, 16 sourcing output base module
1790-T0B16X	24V dc, 16 sourcing output expansion module
1790D-T0B32	24V dc, 32 sourcing output base module
1790D-T0V16	24V dc, 16 sinking output base module
1790-T0V16X	24V dc, 16 sinking output expansion module
1790D-T0V32	24V dc, 32 sinking output base module
1790D-T0W6	6-relay output base module
1790-T0W8X	8-relay output expansion module
1790D-T16BV0	24V dc, 16 universal input base module
1790-T16BV0X	24V dc, 16 universal input expansion module
1790D-T32BV0	24V dc, 32 universal input base module
1790D-T8A0	120V ac, 8 input base module
1790-T8A0X	120V ac, 8 input expansion module
1790D-T8BV8B	24V dc, 8 universal input/8 sourcing output base module
1790-T8BV8BX	24V dc, 8 universal input/8 sourcing output expansion module
1790D-T16BV16B	24V dc, 16 universal input/16 sourcing output base module
1790D-T8BV8V	24V dc, 8 universal input/8 sinking output base module
1790-T8BV8VX	24V dc, 8 universal input/8 sinking output expansion module
1790D-T16BV16V	24V dc, 16 universal input/16 sinking output base module
1790D-T4R0	4-channel input RTD base module
1790D-T4T0	4-channel input thermocouple base module
1790D-TN0C2	2-channel analog current output module
1790D-TN0V2	2-channel analog voltage output module
1790D-TN4C0	4-channel analog current input module
1790D-TN4V0	4-channel analog voltage input module

Features

CompactBlock LDX I/O for DeviceNet modules are compatible with PLC, SLC, SoftLogix, or Logix programmable controllers by using DeviceNet scanners. All CompactBlock LDX I/O module values are accessible through the data tables of the PLC or SLC programmable controller.

Set node addresses on the modules by using rotary switches on the base module, RSNetWorx for DeviceNet software, or a similar configuration tool. Set the baud rate by using a similar configuration tool.

Benefits

- Wide breadth of I/O types can handle diverse commercial applications.
- Units expand up to 4 digital modules for flexibility of node size (6...64 points).
- Base modules have a built-in DeviceNet adapter.
 - Digital base modules (24V dc, 120V ac, and relay) support up to three digital expansion modules.
 - Analog base modules (current and voltage) support up to two digital expansion modules.
 - RTD and thermocouple base modules do not support expansion modules.
- Universal sink and source inputs reduce the number of components to stock and allow flexibility of input types.
- Units are compatible with a broad range of sensors that include:
 - NEMA/IEC Type 3 compliance for dc modules.
 - NEMA/IEC Type 1 compliance for ac modules.
- Very compact units can fit into confined areas - 104 x 52 x 42 mm (4 x 2 x 1.6 in.).
- Selectable termination types - removable D-shell and fixed-screw termination - are available.
- Units are easy to connect and configure by using modular EDS files.
- Installation and configuration costs are minimized.
- Units are ODVA conformance tested, which means there is a high level of interoperability with other DeviceNet products.
- Resistance temperature detector (RTD) and thermocouple modules support a wide range of sensors and have on-board scaling.
- Cyclic and change-of-state messaging increases network throughput and productivity.
- Auto baud rate detection is available.
- Units mount horizontally or vertically on a DIN rail.
- Units are UL/cUL-listed and CE-certified.

Typical Configuration

This illustration shows how CompactBlock LDX I/O modules fit into a typical DeviceNet system.

CompactBlock LDX I/O Modules in a DeviceNet System

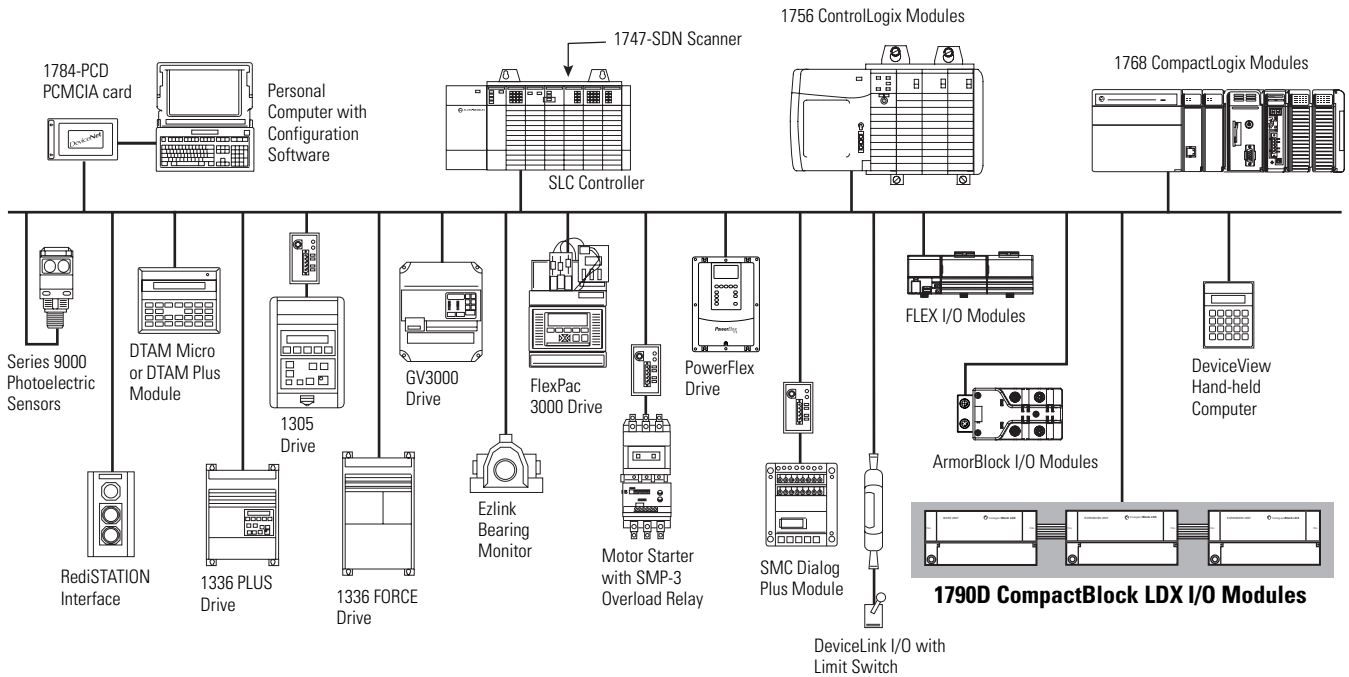

44412

System Compatibility

CompactBlock LDX I/O modules are compatible with any programmable controllers when used with DeviceNet scanners.

CompactBlock LDX I/O Family Module Communication

The CompactBlock LDX I/O modules act as slaves in a master/slave environment. I/O data is exchanged with the master through a polled, cyclic, or change-of-state connection. This selection is made in the DeviceNet scanner module's configuration.

Polled

When the CompactBlock LDX I/O module is configured as a polled device, a master initiates communication by sending its polled I/O message to the module. The module consumes the message, updates any outputs, and produces a response. If any inputs are present, the response contains the input data.

Cyclic

When using cyclic operation, the master sends data only to the CompactBlock LDX I/O module and receives data only from the module at a preconfigured time interval.

Change-of-state

When the CompactBlock LDX I/O modules are configured for change-of-state, the master sends output data only when:

- the user's control program wants to update the module's output.
- the time period for communication has expired.

The CompactBlock LDX I/O module's input data is sent to the master only when:

- an input changes.
- the time period for communication has expired.

With change-of-state, the master does not have to request input data from the slave. It is sent automatically when data changes. In addition, an adjustable "heartbeat" is produced periodically by the CompactBlock LDX I/O module to let the consuming device know that the module connection is alive and ready to communicate.

Software and EDS File Requirements

CompactBlock LDX I/O modules require RSNetWorx for DeviceNet software, version 3.0 or later. We recommend the use of RSNetworx for DeviceNet software, version 7.0 or later. Additionally, current functions of CompactBlock LDX I/O modules require current, modular EDS files for RSNetWorx for DeviceNet software.

These files are easy to install and are available online at <http://www.ab.com/networks/eds/>.

EDS files for modules with matching catalog numbers (for D-shell and terminal block versions) are the same. On the website or in RSNetWorx for DeviceNet software, you can see only one catalog number listed for both versions.

Status Indicators

Each CompactBlock I/O module has indicators to provide a diagnostic readout.

Status Indicators

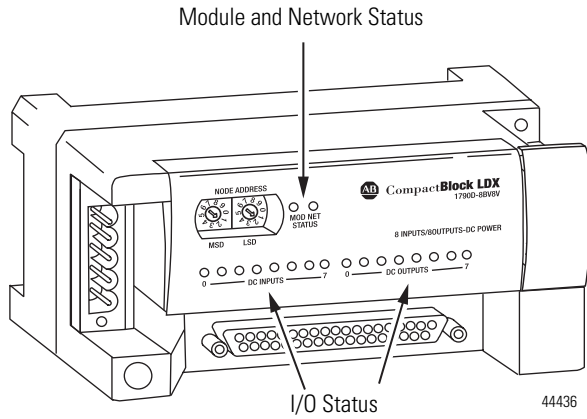

16-bit Base Module

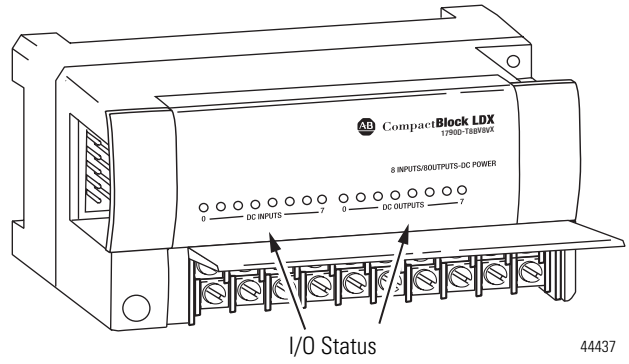

16-bit Expansion Module

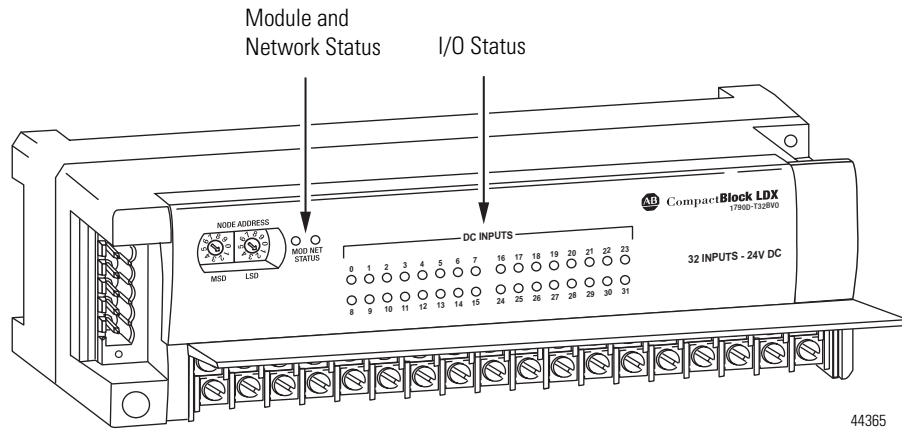

32-bit Base Module

Module/Network Status Indicators - All Base Modules

Indication	Probable Cause	Recommended Action
Module Status		
Solid Red	Unrecoverable fault in base unit.	Replace base module.
Flashing Red	Fault in expansion unit, or node address switches do not match current node address.	Reconnect or replace, as needed.
Solid Green	Normal operation.	None.
Off	No power.	Apply power to device.
Network Status		
Solid Red	Module node number is a duplicate of an existing node, or network communication issues exist.	Change module node number to an unused address, or verify network wiring is correct and communication is stable.
Flashing Red	An I/O connection has timed out.	Cycle power to the module.
Solid Green	The module is operating in a normal condition, and the module is online with connections in the established state. As a group 2 module, the module is allocated to a master.	None.
Flashing Green	The module is online with no connections in the established state.	Establish connections to other nodes. As a group 2 module, allocate the module to a master.
Off	No power.	Wait until the module has completed the dup_MAC_id test or power the module.

I/O Status Indicators - Digital Base and Expansion Modules

I/O Status Indicators			
Function	LED Color	Module Illumination	Condition
Outputs	Each output Green	None. Green.	Output not energized. Output energized.
Inputs	Each input Green	None. Green.	No valid input. Valid input

I/O Status Indicators - Analog Base Modules

1790D-NOV2, 1790D-TNOV2 Analog Voltage Output Module		1790D-NOC2, 1790D-TNOC2 Analog Current Output Module	
Status	Description	Status	Description
Flashing Green/Red	Power up	Flashing Green/Red	Power up
Off	Offline	Off	Offline
Off	Online and no field power	Off	Online and no field power
Solid Green	DeviceNet connection and no field power	Green	DeviceNet connection and no field power
Solid Green	Field power and open wire	Green	Field power and open wire
Solid Green	Field power and valid output	Green	Field power and valid output
Flashing Red	Field power and output out of range	Flashing Red	Field power and output out of range
Flashing Green	Output idle	Flashing Green	Output idle
Flashing Red	Recoverable fault	Flashing Red	Recoverable fault

I/O Status Indicators - Analog Base Modules

1790D-N4V0, 1790D-TN4V0		1790D-N4C0, 1790D-TN4C0	
Status	Description	Status	Description
Flashing Green/Red	Power up	Flashing Green/Red	Power up
Off	Offline	Off	Offline
Solid Red	Online and no field power	Red	Online and no field power
Solid Red	DeviceNet connection and no field power	Red	DeviceNet connection and no field power
Solid Green	Field power and open wire	Flashing Red ⁽¹⁾	Field power and open wire (4...20 mA range only) ⁽²⁾
Solid Green	Field power and valid input	Green	Field power and valid input
Solid Green	Input over range	Green	Input over range
Solid Green	Input under range	Flashing Red ⁽¹⁾	Input under range < 3 mA (4...20 mA range only) ⁽²⁾
Flashing Red	Recoverable fault	Flashing Red	Recoverable fault

⁽¹⁾ Green for 0...20 mA range.

⁽²⁾ Can be determined from the data table.

I/O Status Indicators - RTD and Thermocouple Base Modules

1790D-4R0, 1790D-4T0	
Status	Description
Flashing Green/Red	Power up
Off	Offline
Solid Red	Online and no field power
Solid Red	DeviceNet connection and no field power
Flashing Red	Field power and open wire
Solid Green	Field power and valid input
Flashing Red	Input over range
Flashing Red	Input under range
Flashing Red	Recoverable fault

Power Supply Requirements

The DeviceNet network supplies power to the CompactBlock I/O base and expansion modules. Inputs and outputs are powered by an external 24V dc source that is independent of the network.

Mounting

You can mount the CompactBlock I/O base and expansion modules directly to a panel or on a DIN rail. The illustration shows the base and expansion modules mounting dimensions.

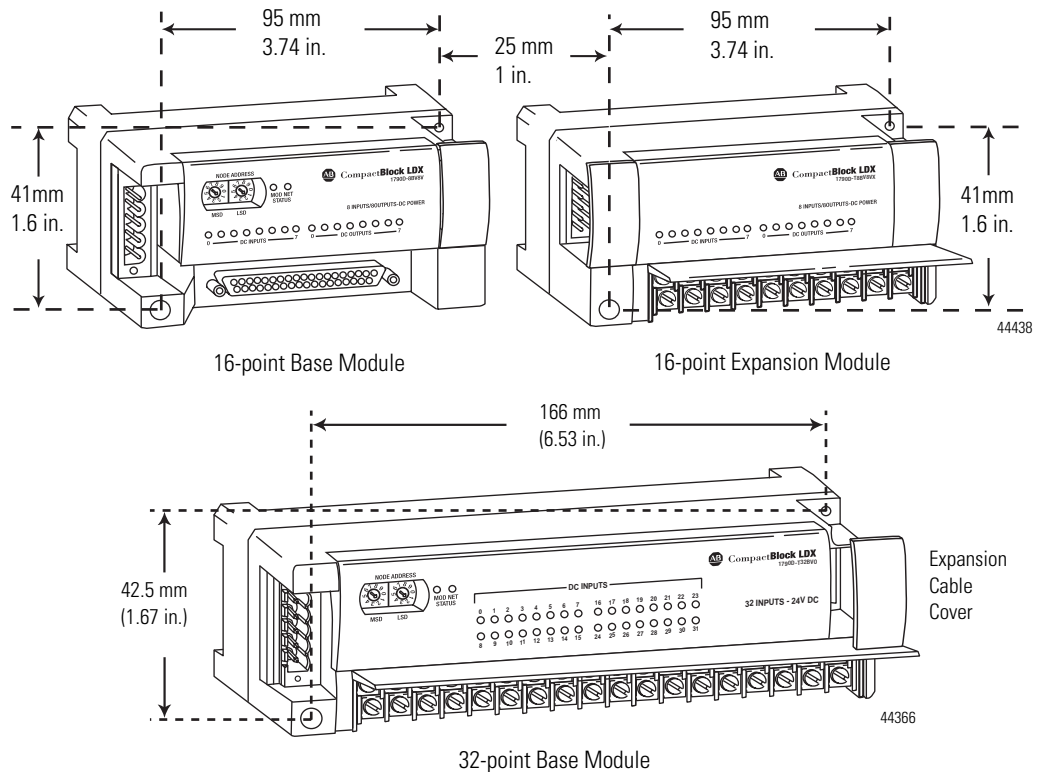

Remember to consider the length of the expansion ribbon cable when installing a base module with an expansion module. The expansion module must be close enough for the expansion cable to reach from the base module to the expansion module.

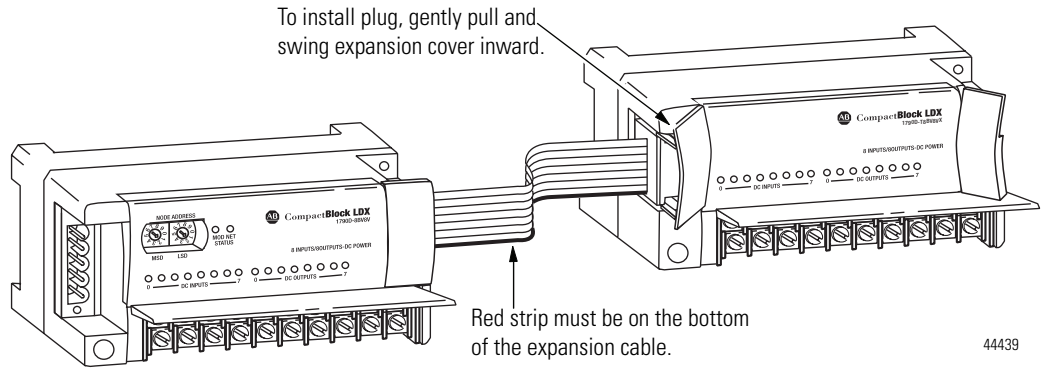

Both digital and analog base modules support up to three expansion modules. Beginning with the base module, you can mount the modules either horizontally or vertically as shown in the figure.

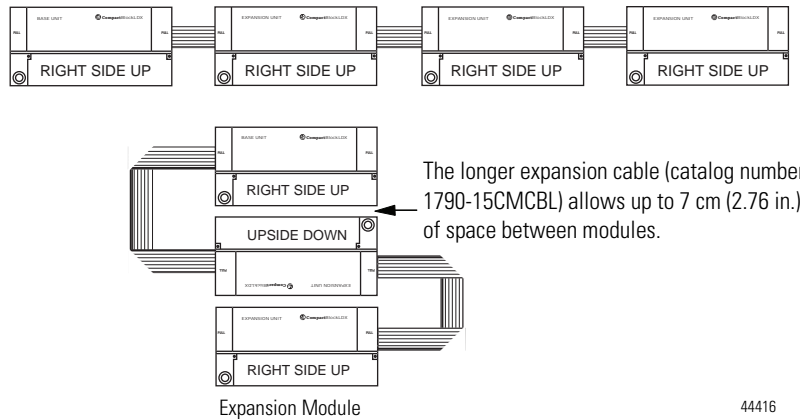

CompactBlock LDX I/O Accessories and DeviceNet Cables

This table lists the optional components for CompactBlock LDX I/O modules.

Optional Components for CompactBlock LDX I/O

Optional Component	Catalog No.
LDX I/O replacement ribbon cable ⁽¹⁾ , 7 cm (2.76 in.), in lots of 5	1790-7CMCBL
LDX I/O longer ribbon cable, 15 cm (5.90 in.), in lots of 5	1790-15CMBL
Five-position open-style plug for the DeviceNet network	1799-DNETCON
Five-position open-style plug/locking screws for the DeviceNet network	1799-DNETSCON
DeviceNet five-position plug to five-pin micro male connector, straight, in lots of five	1799-DNC5MMS

⁽¹⁾ Included with expansion module.

This table lists the DeviceNet cables for CompactBlock LDX I/O modules.

DeviceNet Cables for CompactBlock LDX I/O

Description	Length m (ft)	Part Number (aluminum)	Part Number (stainless steel)	Application
Mini male to conductor (unshielded)	1 (3.3)	1485-P1M5-C	1485RS-P1M5-C	DeviceNet drop cable (flat media)
	6 (19.7)	1485R-P6M5-C	1485RS-P6M5-C	
Mini male to conductor (shielded)	1 (3.3)	1485R-P1M5-C	1485P-1M5-C	DeviceNet drop cable (round media)
	2 (6.6)	1485R-P2M5-C	1485RS-P2M5-C	
	3 (9.8)	1485RS-P3M5-C	1485RS-P3M5-C	

DeviceNet Digital and Analog D-Shell Blocks

General Specifications

The table contains specifications that are common to all of the DeviceNet base and expansion modules in this section. Individual module connection sizes, word, and bit definitions, schematics, wiring diagrams, and specifications are detailed after this table.

Environmental Specifications	
Attribute	Value
Operating temperature	0...55 °C (32...131 °F) for Series A 0...60 °C (32...140 °F) for Series B IEC 60068-2-1 (Test Ad, Operating Cold), IEC 60068-2-2 (Test Bd, Operating Dry Heat), IEC 60068-2-14 (Test Nb, Operating Thermal Shock)
Storage temperature	-40...85 °C (-40...185 °F) IEC 60068-2-1 (Test Ab, Unpackaged Nonoperating Cold), IEC 60068-2-2 (Test Bb, Unpackaged Nonoperating Dry Heat), IEC 60068-2-14 (Test Na, Unpackaged Nonoperating Thermal Shock)
Relative humidity	5...90% noncondensing IEC 60068-2-30 (Test Db, Unpackaged Nonoperating)
Operating altitude	2000 m
Vibration	5g @ 10...500 Hz EC60068-2-6 (Test Fc, Operating)
Shock: operating nonoperating	30 g IEC60068-2-27 Test Ea, (Unpackaged Shock) 50 g IEC60068-2-27 Test Ea, (Unpackaged Shock)
Emissions	Group 1, Class A CISPR 11
ESD immunity	8 kV air discharges IEC 61000-4-2
Radiated RF immunity	10V/m with 1 kHz sine-wave 80%AM from 80 MHz...1000 MHz 10V/m with 200 Hz 50% Pulse 100%AM @ 900 MHz IEC 61000-4-3
EFT/B immunity	±1 kV @ 5 kHz on power ports +2 kV @ 5 kHz on signal ports ±2 kV @ 5 kHz on communications ports IEC 61000-4-4
Surge transient immunity	±1 kV line-line (DM) and ±2 kV line-earth (CM) on power ports ±1 kV line-line (DM) and ±2 kV line-earth (CM) on signal ports ±2 kV line-earth (CM) on shielded ports IEC 61000-4-5
Conducted RF immunity	10V rms with 1 kHz sine-wave 80%AM from 150 kHz...80 MHz IEC 61000-4-6
Enclosure type rating	None (open style)
Mounting	DIN rail or screw
Dimensions (HxWxD), approx.	52 x 104 x 42 mm (2.03 x 4.07 x 1.64 in.)
Weight, approx.	0.3 lb (0.1 kg)

DeviceNet Specifications	
Network protocol	I/O Slave messaging: Poll command, Bit Strobe command, Cyclic command, COS command
Network length	500 m max @ 125 Kbps, 100 m max @ 500 Kbps
Indicators	1 red/green module status, 1 red/green network status
Number of nodes	64 max - rotary switch type node address setting
Communication rate	125 Kbps, 250 Kbps, 500 Kbps - auto baud rate selection
Isolation voltage	50V dc (continuous), Reinforced Insulation Type Tested at 1250V dc for 60 s, I/O to system
Wire size	0.25...2.5 mm ² (22...14 AWG) solid or stranded copper wire rated at 75 °C or greater 1.2 mm (3/64 in.) insulation max
General Specifications	
Wiring category ⁽¹⁾	2 - on signal ports 2 - on power ports 2 - on communications ports
Product certifications ⁽²⁾ (when product or packaging is marked)	c-UL-us UL Listed Industrial Control Equipment, certified for U.S. and Canada. See UL File E150833. c-UL-us UL Listed for Class I, Division 2, Group A,B,C,D Hazardous Locations, certified for U.S. and Canada. See UL File E195620. European Union 89/336/EEC EMC Directive, compliant with: EN 50082-2; Industrial Immunity EN 61326; Meas./Control/Lab., Industrial Requirements EN 61000-6-2; Industrial Immunity EN 61000-6-4; Industrial Emissions European Union 73/23/EEC LVD, compliant with: EN61131-2; Programmable Controllers C-Tick Australian Radiocommunications Act, compliant with AS/NZS CISPR11; Industrial Emissions Open Device Vendors Association (ODVA) conformance tested to DeviceNet specifications

⁽¹⁾ Use this wiring category information for planning conductor routing. Refer to Industrial Automation Wiring and Grounding Guidelines, publication [1770-4.1](#).

⁽²⁾ See the Product Certification link at <http://www.ab.com> for Declarations of Conformity, Certificates, and other certification details.

Module Information

This section contains detailed information for each CompactBlock LDX I/O module in these areas:

- Simplified schematic diagrams
- Connection sizes
- Word and bit definitions
- Connection wiring diagrams
- Module specifications

24V dc 16 Sourcing Output Base and Expansion Modules (1790D-OB16 and 1790-OB16X)

Simplified Schematic

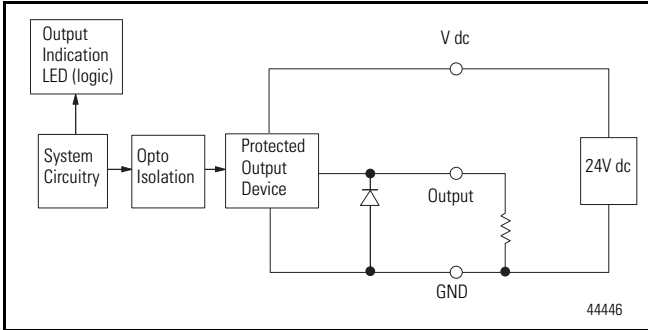

Connection Sizes

Modules	I/O Points	Produce (input bytes)	Consume (output bytes)
1790D-OB16 and 1790-OB16X	16 outputs	0 default 1 input with status ⁽¹⁾	2

⁽¹⁾ Available with series B or later.

Word/Bit Definitions

Input with Status Assembly Selected (1790D-OB16)								
Bit	07	06	05	04	03	02	01	00
Produces 0	Status ⁽¹⁾							

- ⁽¹⁾ Status indicates status of base and expansion modules, **available with series B or later**. There is no specific bit for Status. This byte will be used for "Status" as below:
- 00 (hex) : Normal operation
 - 01 (hex) : EEPROM Checksum fault
 - 02 (hex) : Too many expansion units
 - 03 (hex) : EEPROM parameter not initialized or Serial Number is zero value
 - 04 (hex) : First expansion unit changed
 - 05 (hex) : Second expansion unit changed
 - 06 (hex) : Third expansion unit changed
 - 11 (hex) : Rotary S/W changed

Bit	07	06	05	04	03	02	01	00
Consumes 0	07	06	05	04	03	02	01	00
Consumes 1	015	014	013	012	011	010	09	08

Word	Bit	Description
Consumes 0	00...07	Output bits - when the bit is set (1), the output will be turned on. Bit 00 corresponds to output 00, bit 01 corresponds to output 01, bit 02 to output 02, bit 03 to output 03, ...
Consumes 1	08...15	Output bits - when the bit is set (1), the output will be turned on. Bit 00 corresponds to output 08, bit 01 corresponds to output 09, bit 02 to output 010, bit 03 to output 011, ...

Wiring Diagram for D-shell Connector

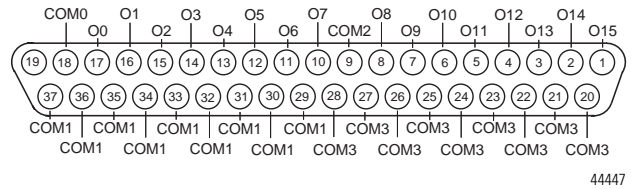

- Sourcing outputs** - wire Com 0 and Com 2 to Field Power (+) 24V dc, wire Com 1 and Com 3 to Field Power (-) GND. Note that all Com 1 and Com 3 are internally connected.

Module Specifications

1790D-OB16 and 1790-OB16X	
Attribute	Value
Outputs per module	16 points nonisolated, sourcing
On-state voltage	10V dc min, 24V dc nom, 28.8V dc max
On-state voltage drop	0.5V dc max
On-state current	1 mA min per channel
Off-state voltage	28.8V dc max
Off-state leakage	0.5 mA max
Output signal delay	Off to On: 0.5 ms max, On to Off: 1.0 ms max
Indicators	16 green status
Output current rating	0.5 A max per output, 4.0 A max per common
Common type	8 points/8 COM for 1790D-OB16
General Specifications	
DeviceNet power - base module	Supply voltage - 24V dc nom Voltage range - 11...28.8V dc Power dissipation - 1.2 W max @ 28.8V dc
Field power	Supply voltage - 24V dc nom Voltage range - 10...28.8V dc Power dissipation - 6 mA @ 28.8V dc per point
Isolation	I/O to logic: photocoupler isolation Isolation voltage: 1250V ac rms
Wiring	37-pin D-shell connector

24V dc 16 Sinking Output Base and Expansion Modules (1790D-0V16 and 1790-0V16X)

Simplified Schematic

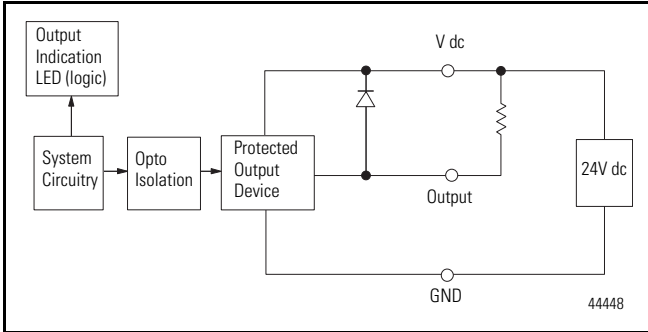

Connection Sizes

Modules	I/O Points	Produce (input bytes)	Consume (output bytes)
1790D-0V16 and 1790-0V16X	16 output	0 default 1 input with status ⁽¹⁾	2

⁽¹⁾ Available with series B or later.

Word/Bit Definitions

Input with Status Assembly Selected (1790D-0V16)								
Bit	07	06	05	04	03	02	01	00
Produces 0	Status ⁽¹⁾							

- ⁽¹⁾ Status indicates status of base and expansion modules, **available with series B or later**. There is no specific bit for Status. This byte will be used for "Status" as below:
- 00 (hex) : Normal operation
 - 01 (hex) : EEPROM Checksum fault
 - 02 (hex) : Too many expansion units
 - 03 (hex) : EEPROM parameter not initialized or Serial Number is zero value
 - 04 (hex) : First expansion unit changed
 - 05 (hex) : Second expansion unit changed
 - 06 (hex) : Third expansion unit changed
 - 11 (hex) : Rotary S/W changed

Bit	07	06	05	04	03	02	01	00
Consumes 0	07	06	05	04	03	02	01	00
Consumes 1	015	014	013	012	011	010	09	08

Word	Bit	Description
Consumes 0	00...07	Output bits - when the bit is set (1), the output will be turned on. Bit 00 corresponds to output 00, bit 01 corresponds to output 01, bit 02 to output 02, bit 03 to output 03, ...
Consumes 1	08...15	Output bits - when the bit is set (1), the output will be turned on. Bit 00 corresponds to output 08, bit 01 corresponds to output 09, bit 02 to output 010, bit 03 to output 011, ...

Wiring Diagram for D-shell Connector

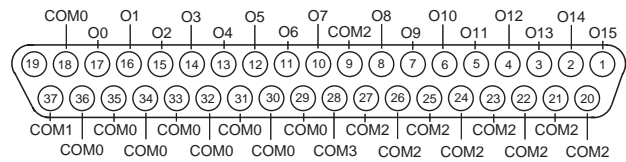

- Sinking outputs** - wire Com 0 and Com 2 to Field Power (+) 24V dc, wire Com 1 and Com 3 to Field Power (-) GND. Note that all Com 0 and Com 2 are internally connected.

Module Specifications

1790D-0V16 and 1790-0V16X

Attribute	Value
Outputs per module	16 points nonisolated, sinking
On-state voltage	10V dc min, 24V dc nom, 28.8V dc max
On-state voltage drop	0.5V dc max
On-state current	1 mA min per channel
Off-state voltage	28.8V dc max
Off-state leakage	0.5 mA max
Output signal delay	Off to On: 0.5 ms max, On to Off: 1.0 ms max
Indicators	16 green status
Output current rating	0.5 A max per output 4.0 A max per common
Common type	8 points/2 COM for 1790D-0V16

General Specifications

DeviceNet power - base module	Supply voltage - 24V dc nom Voltage range - 11...28.8V dc Power dissipation - 1.2 W max @ 28.8V dc
Field power	Supply voltage - 24V dc nom Voltage range - 10...28.8V dc Power dissipation - 6 mA @ 28.8V dc per point
Isolation	I/O to logic: photocoupler isolation Isolation voltage: 1250V ac rms
Wiring	37-pin D-shell connector

6-relay Output Base Module (1790D-0W6)

Simplified Schematic

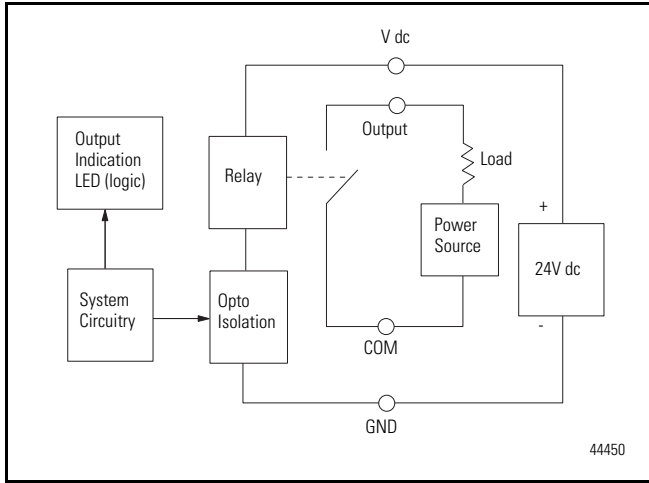

Connection Sizes

Module	I/O Points	Produce (input bytes)	Consume (output bytes)
1790D-0W6	6 outputs	0 default 1 input with status ⁽¹⁾	1

⁽¹⁾ Available with series B or later.

Word/Bit Definitions

Input with Status Assembly Selected (1790D-0W6)								
Bit	07	06	05	04	03	02	01	00
Produces 0	Status ⁽¹⁾							

⁽¹⁾ Status indicates status of base and expansion modules, **available with series B or later**. There is no specific bit for Status. This byte will be used for "Status" as below:

1. 00 (hex) : Normal operation
2. 01 (hex) : EEPROM Checksum fault
3. 02 (hex) : Too many expansion units
4. 03 (hex) : EEPROM parameter not initialized or Serial Number is zero value
5. 04 (hex) : First expansion unit changed
6. 05 (hex) : Second expansion unit changed
7. 06 (hex) : Third expansion unit changed
8. 11 (hex) : Rotary S/W changed

Bit	05	04	03	02	01	00
Consumes 0	05	04	03	02	01	00

Word	Bit	Description
Consumes 0	00...06	Output bits - when the bit is set (1), the output will be turned on. Bit 00 corresponds to output 00, bit 01 corresponds to output 01, bit 02 to output 02, bit 03 to output 03, ...

Wiring Diagram for D-shell Connector

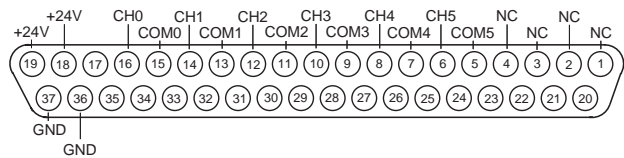

44451

- Wire pins 18 and 19 to Field Power (+) 24V dc.
Wire pins 36 and 37 to Field Power (-) GND.

Module Specifications

1790D-0W6	
Attribute	Value
Relay type	Form A, normally open Single pole, single throw
Output voltage range (load dependent)	5...28.8V dc @ 2.0 A resistive 30V ac @ 2.0 A resistive
Output current rating (at rated power)	2.0 A @ 5...28.8V dc resistive 2.0 A @ 30V ac resistive
Load, min	100 µA, 100 mV dc per input
On-state voltage drop, max	0.5V @ 2.0 A, resistive load, 24V dc
Initial contact resistance	30 mΩ
Expected contact life	300 Kcycles resistive, 100 Kcycles inductive
Off-state leakage, max	1.5 mA max
Output delay time	Off to On: 10 ms max, On to Off: 10 ms max
Indicators	6 green status
Common type	1 point/1 COM
General Specifications	
DeviceNet power	Supply voltage - 24V dc nom Voltage range - 11...28.8V dc Power dissipation - 1.2 W max @ 28.8V dc
Field power	Supply voltage - 24V dc nom Voltage range - 19.2...28.8V dc Power dissipation - 10 mA @ 28.8V dc per channel
Isolation	I/O to logic: photocoupler isolation Isolation voltage: 1250V ac rms
Wiring	37-pin D-shell connector

8-relay Output Expansion Module - 1790-0W8X

Simplified Schematic

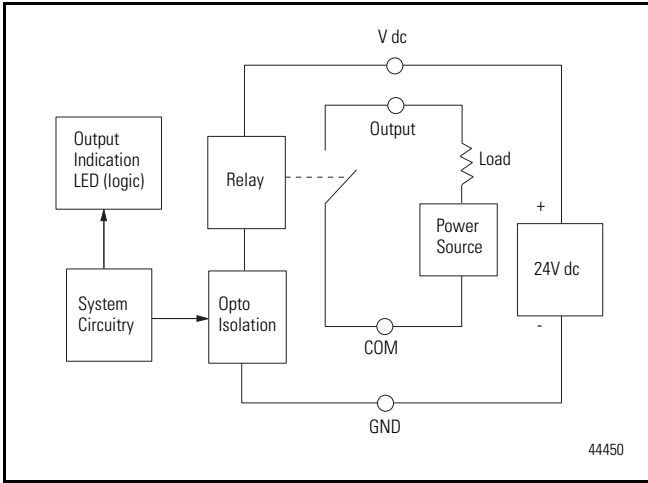

Connection Sizes

Module	I/O Points	Produce (input bytes)	Consume (output bytes)
1790-0W8X	8 outputs	0	1

Word/Bit Definitions

Bit	07	06	05	04	03	02	01	00
Consumes 0	07	06	05	04	03	02	01	00

Word	Bit	Description
Consumes 0	00...08	Output bits - when the bit is set (1), the output will be turned on. Bit 00 corresponds to output 00, bit 01 corresponds to output 01, bit 02 to output 02, bit 03 to output 03, ...

Wiring Diagram for D-shell Connector

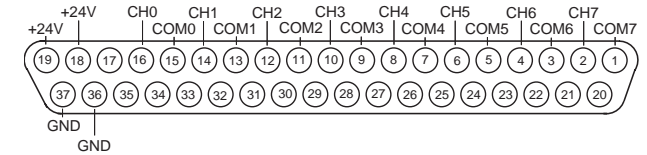

44452

- Wire pins 18 and 19 to Field Power (+) 24V dc.
Wire pins 36 and 37 to Field Power (-) GND.

Module Specifications

1790-0W8X

Attribute	Value
Relay type	Form A, normally open Single pole, single throw
Output voltage range (load dependent)	5...24V dc @ 2.0 A resistive 30V ac @ 2.0 A resistive
Output current rating (at rated power)	2.0 A @ 5...24V dc resistive 2.0 A @ 30V dc resistive
Load, min	100 µA, 100 mV dc per input
On-state voltage drop, max	0.5V @ 2.0 A, resistive load, 24V dc
Initial contact resistance	30 mΩ
Expected contact life	300 Kcycles resistive 100 Kcycles inductive
Off-state leakage, max	1.5 mA max
Output delay time	Off to On: 10 ms max, On to Off: 10 ms max
Indicators	8 green status
Common type	1 point/1 COM

General Specifications

Field power	Supply voltage - 24V dc nom Voltage range - 19.2...28.8V dc Power dissipation - 10 mA @ 28.8V dc per channel
Isolation	I/O to logic: photocoupler isolation Isolation voltage: 1250V ac rms
Wiring	37-pin D-shell connector

24V dc 16 Universal Input Base and Expansion Modules (1790D-16BV0 and 1790-16BV0X)

Simplified Schematic

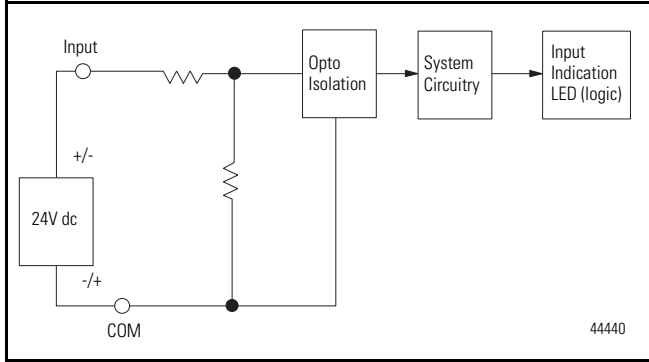

Connection Sizes

Modules	I/O Points	Produce (input bytes)	Consume (output bytes)
1790D-16BV0, 1790-16BV0X	16 input	2 default 3 inputs with status ⁽¹⁾	0

⁽¹⁾ Available with series B or later.

Word/Bit Definitions

Default (1790D-16BV0 and 1790-16BV0X)								
Bit	07	06	05	04	03	02	01	00
Produces 0	I7	I6	I5	I4	I3	I2	I1	I0
Produces 1	I15	I14	I13	I12	I11	I10	I9	I8

Word	Bit	Description
Produces 0	00...07	Input bits - when the bit is set (1), the input is on. Bit 00 corresponds to input I0, bit 01 corresponds to input I1, bit 02 corresponds to input I2, bit 03 corresponds to input I3, ...
Produces 1	08...15	Input bits - when the bit is set (1), the input is on. Bit 00 corresponds to input I8, bit 01 corresponds to input I9, bit 02 corresponds to input I10, bit 03 corresponds to input I11, ...

Inputs with Status Assembly Selected (1790D-16BV0)								
Bit	07	06	05	04	03	02	01	00
Produces 0	Status ⁽¹⁾							
Produces 1	I15	I14	I13	I12	I11	I10	I9	I8
Produces 2	I23	I22	I21	I20	I19	I18	I17	I16

⁽¹⁾ Status indicates status of base and expansion modules, **available with series B or later**. There is no specific bit for Status. This byte will be used for "Status" as below:

- 00 (hex) : Normal operation
- 01 (hex) : EEPROM Checksum fault
- 02 (hex) : Too many expansion units
- 03 (hex) : EEPROM parameter not initialized or Serial Number is zero value
- 04 (hex) : First expansion unit changed
- 05 (hex) : Second expansion unit changed
- 06 (hex) : Third expansion unit changed
- 11 (hex) : Rotary S/W changed

Word	Bit	Description
Produces 0	00...07	Status byte
Produces 1	08...15	Input bits - when the bit is set (1), the input is on. Bit 00 corresponds to input I0, bit 01 corresponds to input I1, bit 02 corresponds to input I2, bit 03 corresponds to input I3, ...
Produces 2	16...23	Input bits - when the bit is set (1), the input is on. Bit 00 corresponds to input I8, bit 01 corresponds to input I9, bit 02 corresponds to input I10, bit 03 corresponds to input I11, ...

Wiring Diagram for D-shell Connector

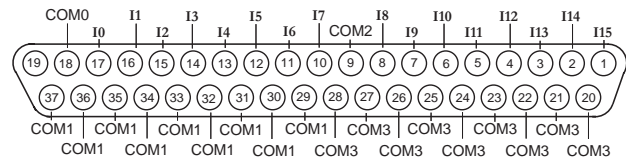

44441

- For inputs 0...7: Sinking inputs** - wire Com 1 to Field Power (+) 24V dc, wire Com 0 to Field Power (-) GND.
Sourcing inputs - wire Com 1 to Field Power (-) GND, wire Com 0 to Field Power (+) 24V dc.
 - For inputs 8...15: Sinking inputs** - wire Com 3 to Field Power (+) 24V dc, wire Com 2 to Field Power (-) GND.
Sourcing inputs - wire Com 3 to Field Power (-) GND, wire Com 2 to Field Power (+) 24V dc.
- Note that all Com 1 and Com 3 are internally connected - Com 1 is used for inputs 0...7, Com 3 is used for inputs 8...15.

Module Specifications

1790D-16BVO and 1790-BVOX	
Attribute	Value
Inputs per block	16 points, sinking or sourcing
On-state voltage	9.6V dc min, 24V dc nom, 28.8V dc max
Off-state voltage	5.0V dc max
On-state current	8 mA max per channel @ 28.8V dc
Input impedance, nom	4.8 K Ω
Indicators	16 green input status
Common type	8 points/8COM (nonpolariy)
General Specifications	
DeviceNet power - base block	Supply voltage - 24V dc nom Voltage range - 11...28.8V dc Power dissipation - 1.2 W max @ 28.8V dc
Isolation	I/O to logic: photocoupler isolation Isolation voltage: 1250V ac rms DeviceNet to logic: nonisolated DeviceNet power: nonisolated
Wiring	37-pin D-shell connector

Module Specifications

1790D-8BV8B, 1790-8BV8BX	
Input Specifications	
Attribute	Value
Inputs per module	8 points nonisolated, sinking or sourcing
On-state voltage	9.6V dc min 24V dc nom 28.8V dc max
On-state current	8 mA max per point @ 28.8V dc
Off-state voltage	5V dc max
Input impedance, nom	4.8 K Ω
Indicators	8 green status
Common type	8 points/8COM (nonpolarity)
Output Specifications	
Outputs per module	8 points nonisolated, sourcing
On-state voltage	10V dc min 24V dc nom 28.8V dc max
On-state voltage drop	0.5V dc max
On-state current	1 mA min per channel
Off-state leakage	0.5 mA max
Output signal delay	Off to On: 0.5 ms max, On to Off: 1.0 ms max
Indicators	8 green status
Output current rating	0.5 A max per output, 4.0 A max per common
Common type	8 points/8 COM - 1790D-8BV8B
General Specifications	
DeviceNet power - base module	Supply voltage - 24V dc nom Voltage range - 11...28.8V dc Power dissipation - 1.2 W max @ 28.8V dc
Field power	Supply voltage - 24V dc nom Voltage range - 10...28.8V dc Power dissipation - 6 mA @ 28.8V dc per point
Isolation	I/O to logic: photocoupler isolation Isolation voltage: 1250V ac rms DeviceNet to logic: nonisolated DeviceNet power: nonisolated
Wiring	37-pin D-shell connector

24V dc 8 Universal Input/8 Sinking Output Base and Expansion Modules (1790D-8BV8V and 1790-8BV8VX)

Simplified Schematic

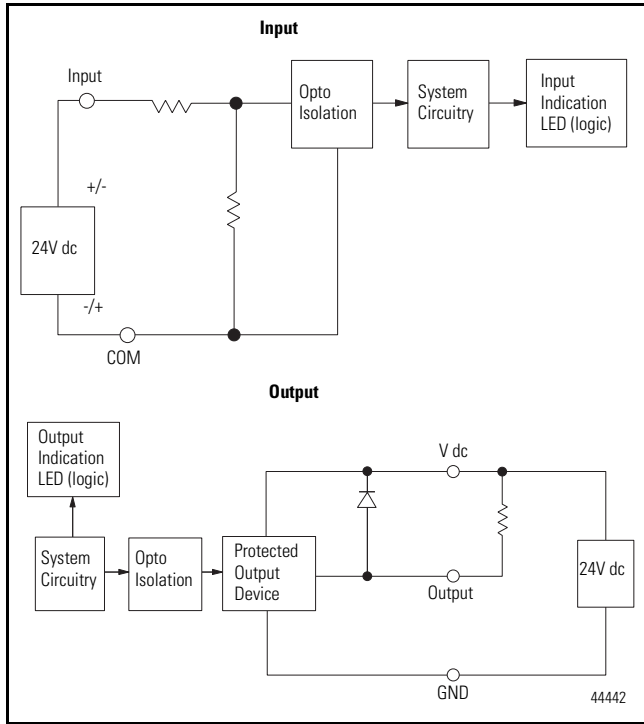

Connection Sizes

Modules	I/O Points	Produce (input bytes)	Consume (output bytes)
1790D-8BV8V, 1790-8BV8VX	8 input/ 8 output	1 default 2 inputs with status ⁽¹⁾	1

⁽¹⁾ Available with series B or later.

Word/Bit Definitions

Default (1790D-8BV8V and 1790-8BV8VX)								
Bit	07	06	05	04	03	02	01	00
Produces 0	I7	I6	I5	I4	I3	I2	I1	I0

Word	Bit	Description
Produces 0	00... 07	Input bits - when the bit is set (1), the input is on. Bit 00 corresponds to input I0, bit 01 corresponds to input I1, bit 02 corresponds to input I2, bit 03 corresponds to input I3, ...

Inputs with Status Assembly Selected (1790D-8BV8V)								
Bit	07	06	05	04	03	02	01	00
Produces 0	Status ⁽¹⁾							
Produces 1	I15	I14	I13	I12	I11	I10	I9	I8

⁽¹⁾ Status indicates status of base and expansion modules, **available with series B or later**. There is no specific bit for Status. This byte will be used for "Status" as below:

- 00 (hex) : Normal operation
- 01 (hex) : EEPROM Checksum fault
- 02 (hex) : Too many expansion units
- 03 (hex) : EEPROM parameter not initialized or Serial Number is zero value
- 04 (hex) : First expansion unit changed
- 05 (hex) : Second expansion unit changed
- 06 (hex) : Third expansion unit changed
- 11 (hex) : Rotary S/W changed

Word	Bit	Description
Produces 0	00... 07	Status byte
Produces 1	08... 15	Input bits - when the bit is set (1), the input is on. Bit 00 corresponds to input I0, bit 01 corresponds to input I1, bit 02 corresponds to input I2, bit 03 corresponds to input I3, ...

Bit	07	06	05	04	03	02	01	00
Consumes	O7	O6	O5	O4	O3	O2	O1	O0

Word	Bit	Description
Consumes	00... 07	Output bits - when the bit is set (1), the output is on. Bit 00 corresponds to output O0, bit 01 corresponds to output O1, bit 02 to output O2, bit 03 to output O3, ...

Wiring Diagram for D-shell Connector

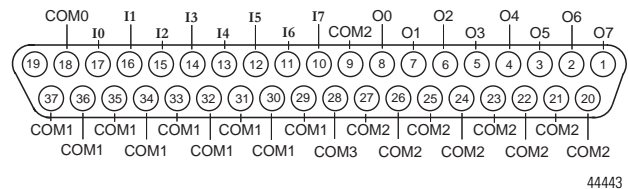

- Sinking inputs** - wire Com 1 to Field Power (+) 24V dc, wire Com 0 to Field Power (-) GND.
- Sourcing inputs** - wire Com 1 to Field Power (-) GND, wire Com 0 to Field Power (+) 24V dc. Note that all Com 1 are internally connected.
- Sinking outputs** - wire Com 2 to Field Power (+) 24V dc, wire Com 3 to Field Power (-) GND. Note that all Com 2 are internally connected.

Module Specifications

1790D-8BV8V and 1790-8BV8VX	
Input Specifications	
Attribute	Value
Inputs per block	8 points nonisolated, sinking or sourcing
On-state voltage	9.6V dc min, 24V dc nom, 28.8V dc max
On-state current	8 mA max per point @ 28.8V dc
Off-state voltage	5V dc max
Input impedance, nom	4.8 K Ω
Indicators	8 green status
Common type	8 points/8COM (nonpolarity)
Output Specifications	
Outputs per block	8 points nonisolated, sinking
On-state voltage	10V dc min, 24V dc nom, 28.8V dc max
On-state voltage drop	0.5V dc max
On-state current	1 mA min per channel
Off-state leakage	0.5 mA max
Output signal delay	Off to On: 0.5 ms max, On to Off: 1.0 ms max
Indicators	8 green status
Output current rating	0.5 A max per output, 4.0 A max per common
Common type	8 points/8 COM
General Specifications	
DeviceNet power - base block	Supply voltage - 24V dc nom Voltage range - 11...28.8V dc Power dissipation - 1.2 W max @ 28.8V dc
Field power	Supply voltage - 24V dc nom Voltage range - 10...28.8V dc Power dissipation - 6 mA @ 28.8V dc per point
Isolation	I/O to logic: photocoupler isolation Isolation voltage: 1250V ac rms DeviceNet to logic: nonisolated DeviceNet power: nonisolated
Wiring	37-pin D-shell connector

Resolution	16 bits across 625 Ω 0.1 °C/bit or 0.1 °F/bit (RTD sensors) 20 bit Sigma-Delta modulation converter
Data format	16 bit integer (2's compliment)
Module scan time	8 ms/channel @ Notch Filter = 60 Hz
Overall accuracy	0.2% Full scale @ 0...55 °C
Settable notch filter	10 Hz (default), 25 Hz, 50 Hz, 60 Hz, 100 Hz, 250 Hz, 500 Hz
Open wire detection	Out of range, open wiring
Excitation current	1 mA
Input impedance	5 m Ω
DeviceNet power	Supply voltage - 24V dc nom Voltage range - 11...28.8V dc Power dissipation - 1.2 W max @ 28.8V dc
Field power	Supply Voltage - 24V dc nom Voltage Range - 21.6...26.4V dc ($\pm 10\%$) Power Dissipation - 1.5 W max @ 26.4V dc
Isolation	I/O to logic: photocoupler isolation Isolation voltage: Type Test 1250V ac rms for 60 s DeviceNet to logic: nonisolated Field power: nonisolated
Indicators	4 red/green I/O status
Wiring	37-pin D-shell connector

IMPORTANT: This module does not support any expansion modules.

4-channel Input Thermocouple Base Module (1790D-4T0)

Simplified Schematic

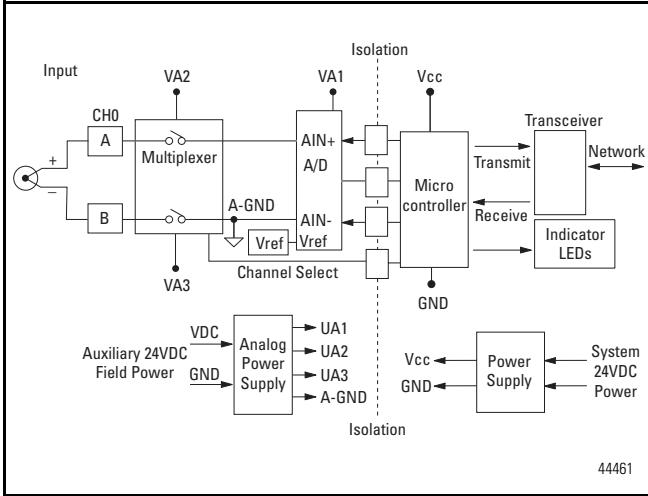

Input Data File

Word	Bit Position															
	15	14	13	12	11	10	9	8	7	6	5	4	3	2	1	0
0	Thermocouple Input Data Channel 0															
1	Thermocouple Input Data Channel 1															
2	Thermocouple Input Data Channel 2															
3	Thermocouple Input Data Channel 3															
4	Not Used			S11	S10	S9	S8	Not Used			S3	S2	S1	S0		

Wiring Diagram for D-shell Connector

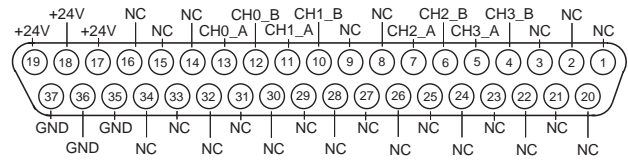

44462

Connection Sizes

Module	I/O Points	Produce (input bytes)	Consume (output bytes)
1790D-4T0	4 channel	10	0

- Wire pins 17, 18 and 19 to Field Power (+) 24V dc. Wire pins 35, 36 and 37 to Field Power (-) GND.

Word/Bit Definitions

Word	Decimal Bit	Description
Read Word 0	Bits 00...15	Channel 0 input data
Read Word 1	Bits 00...15	Channel 1 input data
Read Word 2	Bits 00...15	Channel 2 input data
Read Word 3	Bits 00...15	Channel 3 input data
Read Word 4	Bits 00...03	Underrange for individual channels - Bit 00 corresponds to input channel 0, bit 01 corresponds to input channel 1 and so on. When set (1) the input signal is below the input channel's minimum range.
	Bits 04...07	Not used: Set to 0
	Bits 08...11	Overrange for individual channels - Bit 08 corresponds to input channel 0, bit 09 corresponds to input channel 1 and so on. When set (1) the input signal is above the input channel's maximum range, or open RTD is detected.
	Bits 12...15	Not used: Set to 0

Module Specifications

1790D-4T0			
Attribute	Value		
Inputs per module	4 channel, thermocouple/mV input		
Input range	±76.50 mV		
Sensors supported	Sensor Type	Range	Scaling
	Voltage 10 µV	-76.50...76.50 mV	-7650...7650
	Type B	300...1800 °C	3000...18,000
	Type E	-270...1000 °C	-2700...10,000
	Type J	-210...1200 °C	-2100...12,000
	Type K	-270...1370 °C	-2700...13,700
	Type R	-50...1768 °C	-500...17,680
	Type S	-50...1768 °C	-500...17,680
	Type T	-270...400 °C	-2700...4000
	Type N	-270...1300 °C	-2700...13,000
Resolution	16 bits, 0.1 °C/bit or 0.1°F/bit (thermocouple sensors) 20 bit Sigma-Delta modulation converter		
Data format	16 bit integer (2's compliment)		
Module scan time	140 ms/channel @ Notch Filter = 60 Hz		
Overall accuracy	0.2% full scale @0 °C...55 °C		
Settable notch filter	10 Hz (default), 25 Hz, 50 Hz, 60 Hz, 100 Hz, 250 Hz, 500 Hz		
Open wire detection	Out of range, open wiring		
Cold junction compensation range	0...70 °C		
Input impedance	5 mΩ		
General Specifications			
DeviceNet power	Supply voltage - 24V dc nom Voltage range - 11...28.8V dc Power dissipation - 1.2 W max @ 28.8V dc		
Field power	Supply voltage - 24V dc nom Voltage range - 21.6...26.4V dc (±10%) Power dissipation - 1.5 W max @26.4V dc		
Isolation	I/O to logic: photocoupler isolation Isolation voltage: Type Test 1250V ac rms for 60 s DeviceNet to logic: nonisolated Field power: nonisolated		
Indicators	4 red/green I/O status		
Wiring	37-pin D-shell connector		
IMPORTANT: This module does not support any expansion modules.			

2-channel Analog Current Output Module (1790D-N0C2)

Simplified Schematic

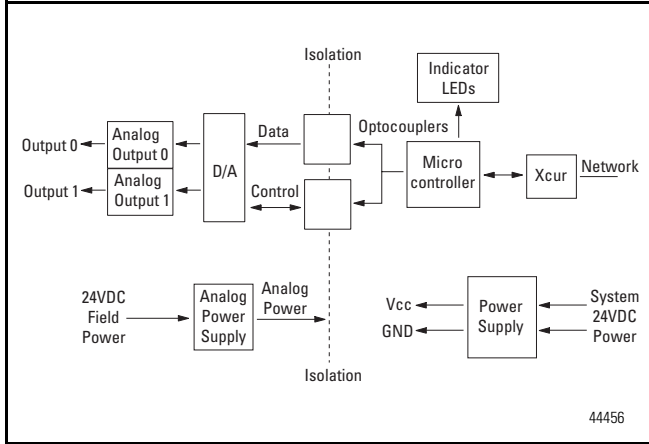

Connection Sizes

Module	I/O Points	Produce (input bytes)	Consume (output bytes)
1790D-N0C2	2 channel	0	4

Word/Bit Definitions

Word	Decimal Bit	Description
Write Word 0	Bits 00...11	Channel 0 output data
	Bits 12...15	Not used: Set to 0
Write Word 1	Bits 00...11	Channel 1 output data
	Bits 12...15	Not used: Set to 0

Output Data File

Word	Bit Position															
	15	14	13	12	11	10	9	8	7	6	5	4	3	2	1	0
0	Not Used				Analog Output Data Channel 0											
1	Not Used				Analog Output Data Channel 1											

Wiring Diagram for D-shell Connector

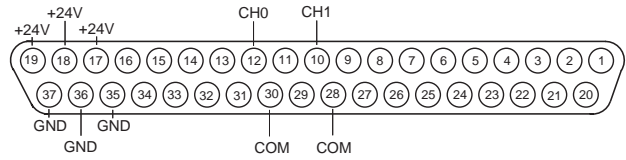

44457

- Wire pins 17, 18 and 19 to Field Power (+) 24V dc.
- Wire pins 35, 36 and 37 to Field Power (-) GND.

Module Specifications

1790D-N0C2	
Attribute	Value
Outputs per module	2 channel single-ended, nonisolated
Output current	0...20 mA
Resolution	12 bits, 1/4096 max, 4.88 μ A/bit
Converted data	Binary data, 0000 to 0fff (max scale)
Conversion time	2ms/channel
Overall accuracy	0.2% full scale @ 0...55 $^{\circ}$ C
Calibration	None required
Allowable external output load resistance	600 Ω max
Insulation resistance	20 m Ω min @ 250V dc (between insulated circuits)

General Specifications	
DeviceNet power	Supply voltage - 24V dc nom Voltage range - 11...28.8V dc Power dissipation - 1.2 W max @ 28.8V dc
Field power	Supply voltage - 24V dc nom Voltage range - 21.6...26.4V dc (\pm 10%) Power dissipation - 1.5 W max @26.4V dc
Isolation	I/O to logic: photocoupler isolation Isolation voltage: Type Test 1250V ac rms for 60 s DeviceNet to logic: nonisolated Field power: nonisolated
Indicators	2 red/green I/O status
Wiring	37-pin D-shell connector

IMPORTANT: This analog base module can accommodate a **maximum** of two discrete expansion modules.

2-channel Analog Voltage Output Module (1790D-NOV2)

Simplified Schematic

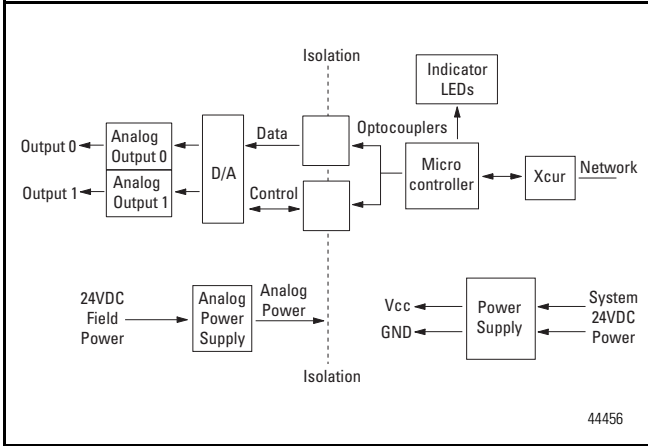

Connection Sizes

Module	I/O Points	Produce (input bytes)	Consume (output bytes)
1790D-NOV2	2 channel	0	4

Word/Bit Definitions

Word	Decimal Bit	Description
Write Word 0	Bits 00...11	Channel 0 output data
	Bits 12...15	Not used: Set to 0
Write Word 1	Bits 00...11	Channel 1 output data
	Bits 12...15	Not used: Set to 0

Output Data File

Word	Bit Position															
	15	14	13	12	11	10	9	8	7	6	5	4	3	2	1	0
0	Not Used				Analog Output Data Channel 0											
1	Not Used				Analog Output Data Channel 1											

Wiring Diagram for D-shell Connector

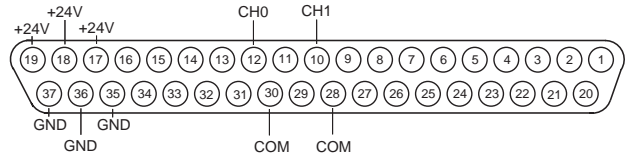

44458

- Wire pins 17, 18 and 19 to Field Power (+) 24V dc.
Wire pins 35, 36 and 37 to Field Power (-) GND.

Module Specifications

1790D-NOV2

Attribute	Value
Outputs per module	2 channel single-ended, nonisolated
Output voltage	0...10V
Resolution	12 bits, 1/4096 max 2.44 mV/bit
Converted data	Binary data 0000 to 0fff (max scale)
Conversion time	2 ms/channel
Overall accuracy	0.2% full scale @ 0 °...55 °C
Calibration	None required
Allowable external output load resistance	1 KΩ min
Output impedance	0.5 Ω max
Insulation resistance	20 mΩ min @ 250V dc (between insulated circuits)

General Specifications

DeviceNet power	Supply voltage - 24V dc nom Voltage range - 11...28.8V dc Power dissipation - 1.2 W max @ 28.8V dc
Field power	Supply voltage - 24V dc nom Voltage range - 21.6...26.4V dc (±10%) Power dissipation - 1.5 W max @ 26.4V dc
Isolation	I/O to logic: photocoupler isolation Isolation voltage: Type Test 1250V ac rms for 60 s DeviceNet to logic: nonisolated Field power: nonisolated
Indicators	2 red/green I/O status
Wiring	37-pin D-shell connector

IMPORTANT: This analog base module can accommodate a **maximum** of two discrete expansion modules.

4-channel Analog Current Input Module (1790D-N4C0)

Simplified Schematic

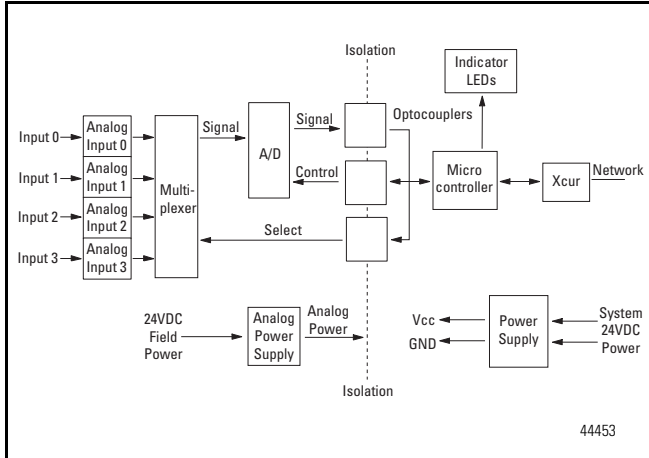

Connection Sizes

Module	I/O Points	Produce (input bytes)	Consume (output bytes)
1790D-N4C0	4 channel	10	0

Word/Bit Definitions

Word	Decimal Bit	Description
Read Word 0	Bits 00...11	Channel 0 input data
	Bits 12...15	Not used: Set to 0
Read Word 1	Bits 00...11	Channel 1 input data
	Bits 12...15	Not used: Set to 0
Read Word 2	Bits 00...11	Channel 2 input data
	Bits 12...15	Not used: Set to 0

Word	Decimal Bit	Description
Read Word 3	Bits 00...11	Channel 3 input data
	Bits 12...15	Not used: Set to 0
Read Word 4	Bits 00...03	Status bits for individual channels - Bit 00 corresponds to input channel 0, bit 01 corresponds to input channel 1 and so on. When set (1) indicates: No field power Open wire (4...20 mA current input only) Under range (4...20 mA current input only) Recoverable module fault (whole channel to be set) Unrecoverable module fault (whole channel to be set)
	Bits 04...15	Not used: Set to 0

Wiring Diagram for D-shell Connector

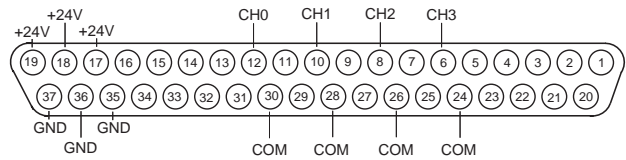

- Wire pins 17, 18 and 19 to Field Power (+) 24V dc.
Wire pins 35, 36 and 37 to Field Power (-) GND.

Input Data File

Word	Bit Position															
	15	14	13	12	11	10	9	8	7	6	5	4	3	2	1	0
0	Not Used											Analog Input Data Channel 0				
1	Not Used											Analog Input Data Channel 1				
2	Not Used											Analog Input Data Channel 2				
3	Not Used											Analog Input Data Channel 3				
4	Not Used												S3	S2	S1	S0

Module Specifications

1790D-N4C0	
Attribute	Value
Inputs per module	4 channel single-ended, nonisolated
Input current (software configurable)	4...20 mA (default) 0...20 mA
Resolution	12 bits-unipolar, 1/4096 max 3.90 μ A/bit (4...20 mA) 4.88 μ A/bit (0...20 mA)
Converted data	Binary data 0000 to 0fff (max scale)
Conversion time	10 ms/channel
Overall accuracy	0.2% full scale @ 0...55 °C
Calibration	None required
Input impedance	249 Ω
Insulation resistance	20 m Ω min @ 250V dc (between insulated circuits)
General Specifications	
DeviceNet power	Supply voltage - 24V dc nom Voltage range - 11...28.8V dc Power dissipation - 1.2 W max @ 28.8V dc
Field power	Supply voltage - 24V dc nom Voltage range - 21.6...26.4V dc (\pm 10%) Power dissipation - 1.5 W max @ 26.4V dc
Isolation	I/O to logic: photocoupler isolation Isolation voltage: Type Test 1250V ac rms for 60 s DeviceNet to logic: nonisolated Field power: nonisolated
Indicators	4 red/green I/O status
Wiring	37-pin D-shell connector
IMPORTANT: This analog base module can accommodate a maximum of two discrete expansion modules.	

4-channel Analog Voltage Input Module (1790D-N4V0)

Simplified Schematic

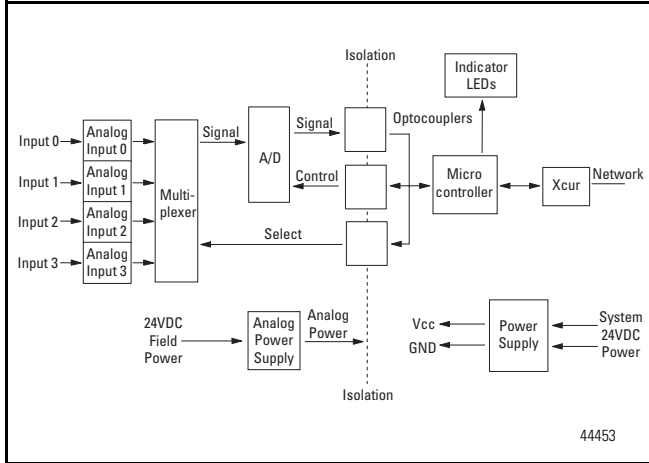

Wiring Diagram for D-shell Connector

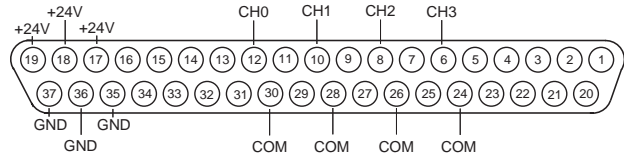

- Wire pins 17, 18 and 19 to Field Power (+) 24V dc.
Wire pins 35, 36 and 37 to Field Power (-) GND.

Input Data File

Word	Bit Position															
	15	14	13	12	11	10	9	8	7	6	5	4	3	2	1	0
0	Not Used				Analog Input Data Channel 0											
1	Not Used				Analog Input Data Channel 1											
2	Not Used				Analog Input Data Channel 2											
3	Not Used				Analog Input Data Channel 3											
4	Not Used												S3	S2	S1	S0

Connection Sizes

Module	I/O Points	Produce (input bytes)	Consume (output bytes)
1790D-N4V0	4 channel	10	0

Word/Bit Definitions

Word	Decimal Bit	Description
Read Word 0	Bits 00...11	Channel 0 input data
	Bits 12...15	Not used: Set to 0
Read Word 1	Bits 00...11	Channel 1 input data
	Bits 12...15	Not used: Set to 0
Read Word 2	Bits 00...11	Channel 2 input data
	Bits 12...15	Not used: Set to 0
Read Word 3	Bits 00...11	Channel 3 input data
	Bits 12...15	Not used: Set to 0
Read Word 4	Bits 00...03	Status bits for individual channels - Bit 00 corresponds to input channel 0, bit 01 corresponds to input channel 1 and so on. When set (1) indicates: No field power Open wire (4...20 mA current input only) Under range (4...20 mA current input only) Recoverable module fault (whole channel to be set) Unrecoverable module fault (whole channel to be set)
	Bits 04...15	Not used: Set to 0

Module Specifications

1790D-N4V0	
Attribute	Value
Inputs per module	4 channel single-ended, nonisolated
Input voltage	0...10V
Resolution	12 bits-unipolar, 1/4096 max, 2.44 mV/bit
Converted data	Binary data 0000 to 0fff (max scale)
Conversion time	10ms/channel
Overall accuracy	0.2% full scale @ 0...55 °C
Calibration	None required
Input impedance	500 KΩmin
Insulation resistance	20 MΩmin @ 250V dc (between insulated circuits)
General Specifications	
DeviceNet power	Supply voltage - 24V dc nom Voltage range - 11...28.8V dc Power dissipation - 1.2 W max @ 28.8V dc
Field power	Supply voltage - 24V dc nom Voltage range - 21.6...26.4V dc (±10%) Power dissipation - 1.5 W max @ 26.4V dc
Isolation	I/O to logic: photocoupler isolation Isolation voltage: Type Test 1250V ac rms for 60 s DeviceNet to logic: nonisolated Field power: nonisolated
Indicators	4 red/green I/O status
Wiring	37-pin D-shell connector

IMPORTANT: This analog base module can accommodate a **maximum** of two discrete expansion modules.

Notes:

DeviceNet Digital and Analog Terminal Blocks

General Specifications

The table contains specifications that are common to all of the DeviceNet base and expansion modules in this section. Individual module connection sizes, word, and bit definitions, schematics, wiring diagrams, and specifications are detailed after this table.

Environmental Specifications	
Attribute	Value
Operating temperature	0...55 °C (32...131 °F) for Series A 0...60 °C (32...140 °F) for Series B IEC 60068-2-1 (Test Ad, Operating Cold), IEC 60068-2-2 (Test Bd, Operating Dry Heat), IEC 60068-2-14 (Test Nb, Operating Thermal Shock)
Storage temperature	-40...85 °C (-40...185 °F) IEC 60068-2-1 (Test Ab, Unpackaged Nonoperating Cold), IEC 60068-2-2 (Test Bb, Unpackaged Nonoperating Dry Heat), IEC 60068-2-14 (Test Na, Unpackaged Nonoperating Thermal Shock)
Relative humidity	5...90% noncondensing IEC 60068-2-30 (Test Db, Unpackaged Nonoperating)
Operating altitude	2000 m
Vibration	5g @ 10...500 Hz EC60068-2-6 (Test Fc, Operating)
Shock: operating nonoperating	30 g IEC60068-2-27 Test Ea, (Unpackaged Shock) 50 g IEC60068-2-27 Test Ea, (Unpackaged Shock)
Emissions	Group 1, Class A CISPR 11
ESD immunity	8 kV air discharges IEC 61000-4-2
Radiated RF immunity	10V/m with 1 kHz sine-wave 80%AM from 80 MHz...1000 MHz 10V/m with 200 Hz 50% Pulse 100%AM @ 900 MHz IEC 61000-4-3
EFT/B immunity	±1 kV @ 5 kHz on power ports +2 kV @ 5 kHz on signal ports ±2 kV @ 5 kHz on communications ports IEC 61000-4-4
Surge transient immunity	±1 kV line-line (DM) and ±2 kV line-earth (CM) on power ports ±1 kV line-line (DM) and ±2 kV line-earth (CM) on signal ports ±2 kV line-earth (CM) on shielded ports IEC 61000-4-5
Conducted RF immunity	10V rms with 1 kHz sine-wave 80%AM from 150 kHz...80 MHz IEC 61000-4-6
Enclosure type rating	None (open style)
Mounting	DIN rail or screw
Dimensions (HxWxD), approx.	52 x 104 x 42 mm (2.03 x 4.07 x 1.64 in.) for 16-point modules 52 x 176 x 42 mm (2.03 x 6.93 x 1.64 in.) for 32-point modules
Weight, approx.	0.3 lb (0.1 kg)

DeviceNet Specifications	
Network protocol	I/O Slave messaging: Poll command, Bit Strobe command, Cyclic command, COS command
Network length	500 m max @ 125 Kbps, 100 m max @ 500 Kbps
Indicators	1 red/green module status, 1 red/green network status
Number of nodes	64 max - rotary switch type node address setting
Communication rate	125 Kbps, 250 Kbps, 500 Kbps - auto baud rate selection
Isolation voltage	50V dc (continuous), Reinforced Insulation Type Tested at 1250V dc for 60 s, I/O to system
Wire size	0.25...2.5 mm ² (22...14 AWG) solid or stranded copper wire rated at 75 °C or greater 1.2 mm (3/64 in.) insulation max
General Specifications	
Wiring category ⁽¹⁾	2 - on signal ports 2 - on power ports 2 - on communications ports
Product certifications ⁽²⁾ (when product or packaging is marked)	c-UL-us UL Listed Industrial Control Equipment, certified for U.S. and Canada. See UL File E150833. c-UL-us UL Listed for Class I, Division 2, Group A,B,C,D Hazardous Locations, certified for U.S. and Canada. See UL File E195620. European Union 89/336/EEC EMC Directive, compliant with: EN 50082-2; Industrial Immunity EN 61326; Meas./Control/Lab., Industrial Requirements EN 61000-6-2; Industrial Immunity EN 61000-6-4; Industrial Emissions European Union 73/23/EEC LVD, compliant with: EN61131-2; Programmable Controllers C-Tick Australian Radiocommunications Act, compliant with AS/NZS CISPR11; Industrial Emissions Open Device Vendors Association (ODVA) conformance tested to DeviceNet specifications

⁽¹⁾ Use this wiring category information for planning conductor routing. Refer to Industrial Automation Wiring and Grounding Guidelines, publication [1770-4.1](#).

⁽²⁾ See the Product Certification link at <http://www.ab.com> for Declarations of Conformity, Certificates, and other certification details.

Module Information

This section contains detailed information for each CompactBlock LDX I/O module in these areas:

- Simplified schematic diagrams
- Connection sizes
- Word and bit definitions
- Connection wiring diagrams
- Module specifications

120V ac, 6 Output Base Module (1790D-T0A6)

Simplified Schematic

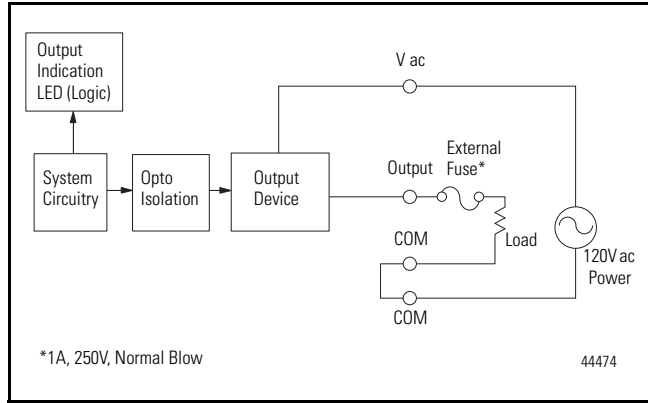

Connection Sizes

Module	I/O Points	Produce (input bytes)	Consume (output bytes)
1790D-T0A6	6 outputs	0 default 1 input with status ⁽¹⁾	1

⁽¹⁾ Available with series B or later.

Word/Bit Definitions

Input with Status Assembly Selected (1790D-T0A6)								
Bit	07	06	05	04	03	02	01	00
Produces 0	Status ⁽¹⁾							

⁽¹⁾ Status indicates status of base and expansion modules, **available with series B or later**. There is no specific bit for Status. This byte will be used for "Status" as below:

1. 00 (hex) : Normal operation
2. 01 (hex) : EEPROM Checksum fault
3. 02 (hex) : Too many expansion units
4. 03 (hex) : EEPROM parameter not initialized or Serial Number is zero value
5. 04 (hex) : First expansion unit changed
6. 05 (hex) : Second expansion unit changed
7. 06 (hex) : Third expansion unit changed
8. 11 (hex) : Rotary S/W changed

Bit	05	04	03	02	01	00
Consumes 0	05	04	03	02	01	00

Word	Bit	Description
Consumes 0	00...06	Output bits - when the bit is set (1), the output will be turned on. Bit 00 corresponds to output 00, bit 01 corresponds to output 01, bit 02 to output 02, bit 03 to output 03, ...

Wiring Diagram for Terminal Block

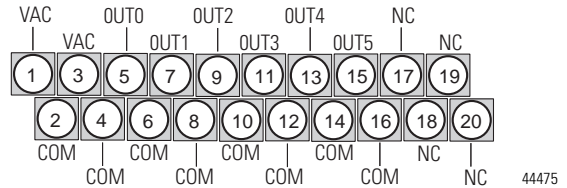

- Wire 120V ac Field Power to V ac (pin 1) and COM (pin 2). Note that all V ac are internally connected. All COM are internally connected.

Module Specifications

1790D-T0A6	
Attribute	Value
Outputs per expansion module	6 points nonisolated
Load voltage range	85...132V ac
Load current, max	0.5 A rms
Load current, min	10 mA rms
Off-state leakage current, max	1.0 mA rms @ 100V rms 60 Hz
On-state voltage drop, max	1.3V rms @ max load
Operate time, max	1 ms
Release, max	1/2 cycle + 1 ms
Insulation resistance	Min 1,000 MΩ (for input-output)
Dielectric strength	2500V rms 1 minute (for input-output)
Indicators	6 green input status
Common type	6 points/6 COM
General Specifications	
DeviceNet power	Supply voltage - 24V dc nom Voltage range - 11...28.8V dc Power dissipation - 1.2 W max @ 28.8V dc
External ac power supply	Supply voltage - 110V rms, 60 Hz Voltage range - 15...132V rms, 60 Hz Power dissipation - 3.9 W @ rated current
Isolation	I/O to logic: photocoupler isolation Isolation voltage: 1250V ac rms/V ac Field power: non-isolation
Wiring	Terminal block (M3.0) - screw torque: 7 lb-in max (use copper or copper-clad aluminum conductors)
Recommended fusing	1 A, 250V, Normal Blow

120V ac, 8 Output Base Module (1790-T0A8X)

Simplified Schematic

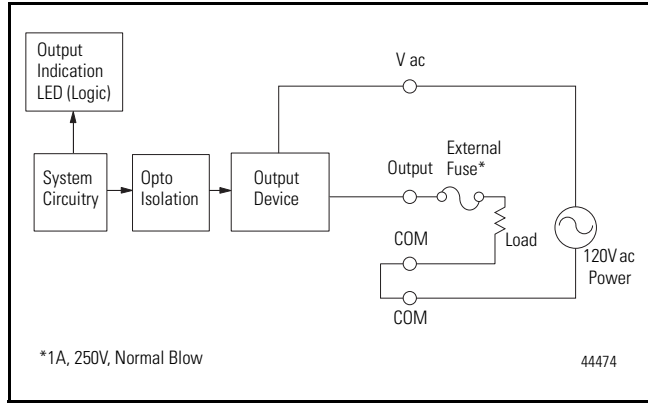

Connection Sizes

Module	I/O Points	Produce (input bytes)	Consume (output bytes)
1790-T0A8X	8 outputs	0	1

Word/Bit Definitions

Bit	07	06	05	04	03	02	01	00
Consumes 0	07	06	05	04	03	02	01	00

Word	Bit	Description
Consumes 0	00...08	Output bits - when the bit is set (1), the output will be turned on. Bit 00 corresponds to output 00, bit 01 corresponds to output 01, bit 02 to output 02, bit 03 to output 03, ...

Wiring Diagram for Terminal Block

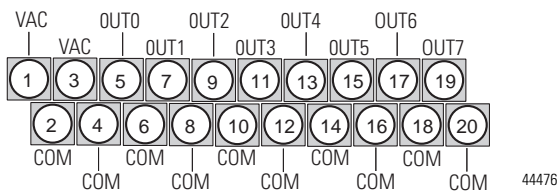

- Wire 120V ac Field Power to V ac (pin 1) and COM (pin 2). Note that all V ac are internally connected. All COM are internally connected.

Module Specifications

1790-T0A8X	
Attribute	Value
Outputs per expansion module	8 points nonisolated
Load voltage range	15...132V rms
Load current, max	0.5 A rms
Load current, min	10 mA rms
Off-state leakage current, max	1.0 mA rms @ 100V rms 60 Hz
On-state voltage drop, max	1.3V rms @ max load
Operate time, max	1 ms
Release, max	1/2 cycle + 1 ms
Insulation resistance	Min 1,000 MΩ (for input-output)
Dielectric strength	2500V rms 1 minute (for input-output)
Indicators	8 green input status
Common type	8 points/8 COM
General Specifications	
External AC power supply	Supply voltage - 110V rms, 60 Hz Voltage range - 15...132V rms, 60 Hz Power dissipation - 5.2 W @ rated current
Isolation	I/O to logic: photocoupler isolation Isolation voltage: 1250V ac rms/V ac Field power: non-isolation
Wiring	Terminal block (M3.0) - screw torque: 7 lb-in max (use copper or copper-clad aluminum conductors)

24V dc 16 Sourcing Output Base and Expansion Modules (1790D-T0B16 and 1790-T0B16X)

Simplified Schematic

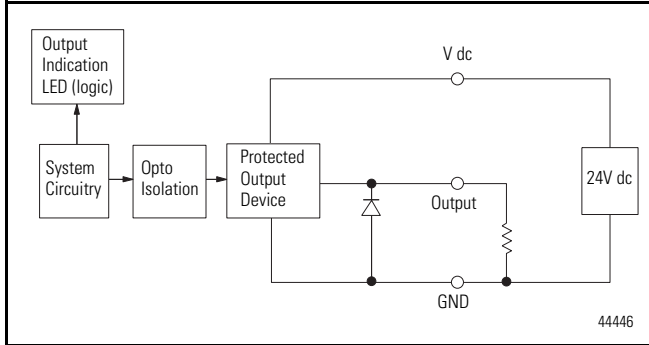

Connection Sizes

Modules	I/O Points	Produce (input bytes)	Consume (output bytes)
1790D-T0B16 and 1790-T0B16X	16 outputs	0 default 1 input with status ⁽¹⁾	2

⁽¹⁾ Available with series B or later.

Word/Bit Definitions

Input with Status Assembly Selected (1790D-T0B16)								
Bit	07	06	05	04	03	02	01	00
Produces 0	Status ⁽¹⁾							

- ⁽¹⁾ Status indicates status of base and expansion modules, **available with series B or later**. There is no specific bit for Status. This byte will be used for "Status" as below:
- 00 (hex) : Normal operation
 - 01 (hex) : EEPROM Checksum fault
 - 02 (hex) : Too many expansion units
 - 03 (hex) : EEPROM parameter not initialized or Serial Number is zero value
 - 04 (hex) : First expansion unit changed
 - 05 (hex) : Second expansion unit changed
 - 06 (hex) : Third expansion unit changed
 - 11 (hex) : Rotary S/W changed

Bit	07	06	05	04	03	02	01	00
Consumes 0	07	06	05	04	03	02	01	00
Consumes 1	015	014	013	012	011	010	09	08

Word	Bit	Description
Consumes 0	00...07	Output bits - when the bit is set (1), the output will be turned on. Bit 00 corresponds to output 00, bit 01 corresponds to output 01, bit 02 to output 02, bit 03 to output 03, ...
Consumes 1	08...15	Output bits - when the bit is set (1), the output will be turned on. Bit 00 corresponds to output 08, bit 01 corresponds to output 09, bit 02 to output 010, bit 03 to output 011, ...

Wiring Diagram for Terminal Module

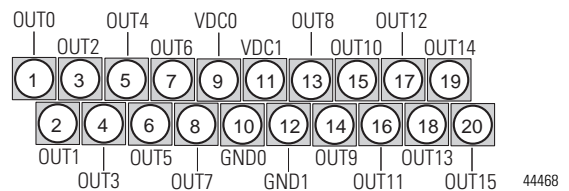

- Sourcing outputs** - wire V dc0 (pin 9) and V dc1 (pin 11) to Field Power (+) 24V dc, wire GND0 (pin 10) and GND1 (pin 12) to Field Power (-) GND.

Module Specifications

1790D-T0B16 and 1790-T0B16X	
Attribute	Value
Outputs per module	16 points nonisolated, sourcing
On-state voltage	10V dc min, 24V dc nom, 28.8V dc max
On-state voltage drop	0.5V dc max
On-state current	1 mA min per channel
Off-state voltage	28.8V dc max
Off-state leakage	0.5 mA max
Output signal delay	Off to On: 0.5 ms max, On to Off: 1.0 ms max
Indicators	16 green status
Output current rating	0.5 A max per output 4.0 A max per common
Common type	8 points/8 COM
General Specifications	
DeviceNet power - base module	Supply voltage - 24V dc nom Voltage range - 11...28.8V dc Power dissipation - 1.2 W max @ 28.8V dc
Field power	Supply voltage - 24V dc nom Voltage range - 10...28.8V dc Power dissipation - 6 mA @ 28.8V dc per point
Isolation	I/O to logic: photocoupler isolation Isolation voltage: 1250V ac rms
Wiring	Terminal block (M3.0) - screw torque: 7 lb-in max (use copper or copper-clad aluminum conductors)

24V dc 32 Sourcing Output Base Module (1790D-T0B32)

Simplified Schematic

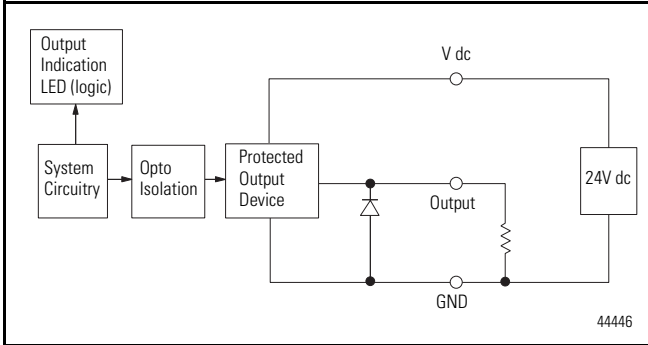

Connection Sizes

Modules	I/O Points	Produce (input bytes)	Consume (output bytes)
1790D-T0B32	32 outputs	0 default 1 input with status	4

Word/Bit Definitions

Inputs with Status Assembly Selected (1790D-T0B32)

Bit	07	06	05	04	03	02	01	00
Produces 0	Status ⁽¹⁾							

⁽¹⁾ Status indicates status of base and expansion modules, **available with series B or later**. There is no specific bit for Status. This byte will be used for "Status" as below:

1. 00 (hex) : Normal operation
2. 01 (hex) : EEPROM Checksum fault
3. 02 (hex) : Too many expansion units
4. 03 (hex) : EEPROM parameter not initialized or Serial Number is zero value
5. 04 (hex) : First expansion unit changed
6. 05 (hex) : Second expansion unit changed
7. 06 (hex) : Third expansion unit changed
8. 11 (hex) : Rotary S/W changed

Bit	07	06	05	04	03	02	01	00
Consumes 0	07	06	05	04	03	02	01	00
Consumes 1	015	014	013	012	011	010	09	08
Consumes 2	023	022	021	020	019	018	017	016
Consumes 3	031	030	029	028	027	026	025	024

Word	Bit	Description
Consumes 0	00...07	Output bits - when the bit is set (1), the output will be turned on. Bit 00 corresponds to output 00, bit 01 corresponds to output 01, bit 02 to output 02, bit 03 to output 03, ...
Consumes 1	08...15	Output bits - when the bit is set (1), the output will be turned on. Bit 00 corresponds to output 08, bit 01 corresponds to output 09, bit 02 to output 010, bit 03 to output 011, ...
Consumes 2	16...23	Output bits - when the bit is set (1), the output will be turned on. Bit 00 corresponds to output 016, bit 01 corresponds to output 017, bit 02 to output 018, bit 03 to output 019, ...
Consumes 3	24...31	Output bits - when the bit is set (1), the output will be turned on. Bit 00 corresponds to output 024, bit 01 corresponds to output 025, bit 02 to output 026, bit 03 to output 027, ...

Wiring Diagram for Terminal Block

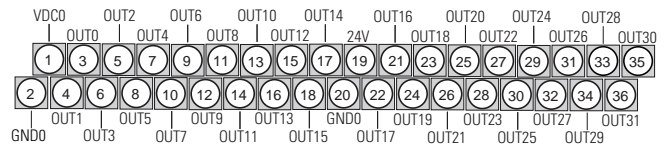

44483

- **Sourcing outputs** - wire VDC0 (pin 1) and VDC1 (pin 19) to Field Power (+) 24V dc, wire GND0 (pin 2) and GND1 (pin 20) to Field Power (-) GND.

Module Specifications

1790D-TOB32	
Attribute	Value
Outputs per module	32 points nonisolated, sourcing
On-state voltage	10V dc min, 24V dc nom, 28.8V dc max
On-state voltage drop	0.5V dc max
On-state current	1 mA min per channel
Off-state voltage	28.8V dc max
Off-state leakage	0.5 mA max
Output signal delay	Off to On: 0.5 ms max, On to Off: 1.0 ms max
Indicators	32 green status
Output current rating	0.5 A max per output 4.0 A max per common
Common type	16 points/2 COM
General Specifications	
DeviceNet power - base module	Supply voltage - 24V dc nom Voltage range - 11...28.8V dc Power dissipation - 1.2 W max @ 28.8V dc
Field power	Supply voltage - 24V dc nom Voltage range - 10...28.8V dc Power dissipation - 6 mA @ 28.8V dc per point
Isolation	I/O to logic: photocoupler isolation Isolation voltage: 1250V ac rms
Wiring	Terminal block (M3.0) - screw torque: 7 lb-in max (use copper or copper-clad aluminum conductors)

24V dc 16 Sinking Output Base and Expansion Modules (1790D-TOV16 and 1790-TOV16X)

Simplified Schematic

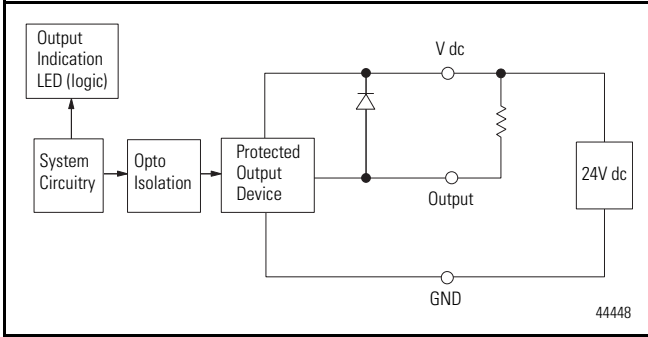

Connection Sizes

Modules	I/O Points	Produce (input bytes)	Consume (output bytes)
1790D-TOV16 and 1790-TOV16X	16 output	0 default 1 input with status ⁽¹⁾	2

⁽¹⁾ Available with series B or later.

Word/Bit Definitions

Input with Status Assembly Selected (1790D-TOV16)								
Bit	07	06	05	04	03	02	01	00
Produces 0	Status ⁽¹⁾							

⁽¹⁾ Status indicates status of base and expansion modules, **available with series B or later**. There is no specific bit for Status. This byte will be used for "Status" as below:

1. 00 (hex) : Normal operation
2. 01 (hex) : EEPROM Checksum fault
3. 02 (hex) : Too many expansion units
4. 03 (hex) : EEPROM parameter not initialized or Serial Number is zero value
5. 04 (hex) : First expansion unit changed
6. 05 (hex) : Second expansion unit changed
7. 06 (hex) : Third expansion unit changed
8. 11 (hex) : Rotary S/W changed

Bit	07	06	05	04	03	02	01	00
Consumes 0	07	06	05	04	03	02	01	00
Consumes 1	015	014	013	012	011	010	09	08

Word	Bit	Description
Consumes 0	00...07	Output bits - when the bit is set (1), the output will be turned on. Bit 00 corresponds to output 00, bit 01 corresponds to output 01, bit 02 to output 02, bit 03 to output 03, ...
Consumes 1	08...15	Output bits - when the bit is set (1), the output will be turned on. Bit 00 corresponds to output 08, bit 01 corresponds to output 09, bit 02 to output 010, bit 03 to output 011, ...

Wiring Diagram for Terminal Module

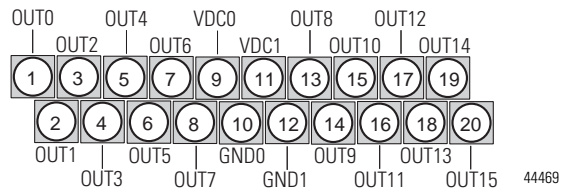

- **Sinking outputs** - wire V dc0 (pin 9) and V dc1 (pin 11) to Field Power (+) 24V dc, wire GND0 (pin 10) and GND1 (pin 12) to Field Power (-) GND.

Module Specifications

1790D-TOV16 and 1790-TOV16X	
Attribute	Value
Outputs per module	16 points nonisolated, sinking
On-state voltage	10V dc min, 24V dc nom, 28.8V dc max
On-state voltage drop	0.5V dc max
On-state current	1 mA min per channel
Off-state voltage	28.8V dc max
Off-state leakage	0.5 mA max
Output signal delay	Off to On: 0.5 ms max, On to Off: 1.0 ms max
Indicators	16 green status
Output current rating	0.5 A max per output 4.0 A max per common
Common type	8 points/2 COM
General Specifications	
DeviceNet power - base module	Supply voltage - 24V dc nom Voltage range - 11...28.8V dc Power dissipation - 1.2 W max @ 28.8V dc
Field power	Supply voltage - 24V dc nom Voltage range - 10...28.8V dc Power dissipation - 6 mA @ 28.8V dc per point
Isolation	I/O to logic: photocoupler isolation Isolation voltage: 1250V ac rms
Wiring	Terminal block (M3.0) - screw torque: 7 lb-in max (use copper or copper-clad aluminum conductors)

24V dc 32 Sinking Output Base Module (1790D-T0V32)

Simplified Schematic

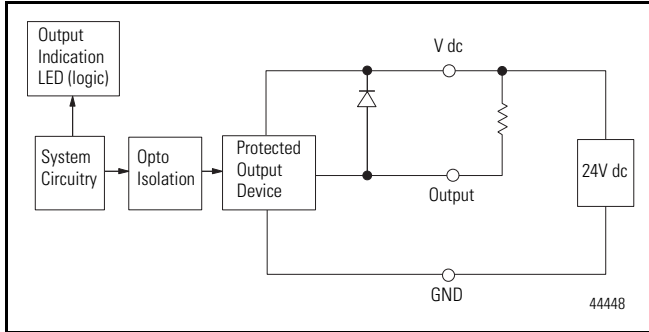

Connection Sizes

Modules	I/O Points	Produce (input bytes)	Consume (output bytes)
1790D-T0V32	32 output	0 default 1 input with status	4

Word/Bit Definitions

Input with Status Assembly Selected (1790D-T0V32)

Bit	07	06	05	04	03	02	01	00
Produces 0	Status ⁽¹⁾							

- ⁽¹⁾ Status indicates status of base and expansion modules, **available with series B or later**. There is no specific bit for Status. This byte will be used for "Status" as below:
- 00 (hex) : Normal operation
 - 01 (hex) : EEPROM Checksum fault
 - 02 (hex) : Too many expansion units
 - 03 (hex) : EEPROM parameter not initialized or Serial Number is zero value
 - 04 (hex) : First expansion unit changed
 - 05 (hex) : Second expansion unit changed
 - 06 (hex) : Third expansion unit changed
 - 11 (hex) : Rotary S/W changed

Bit	07	06	05	04	03	02	01	00
Consumes 0	07	06	05	04	03	02	01	00
Consumes 1	015	014	013	012	011	010	09	08
Consumes 2	023	022	021	020	019	018	017	016
Consumes 3	031	030	029	028	027	026	025	024

Word	Bit	Description
Consumes 0	00...07	Output bits - when the bit is set (1), the output will be turned on. Bit 00 corresponds to output 00, bit 01 corresponds to output 01, bit 02 to output 02, bit 03 to output 03, ...
Consumes 1	08...15	Output bits - when the bit is set (1), the output will be turned on. Bit 00 corresponds to output 08, bit 01 corresponds to output 09, bit 02 to output 010, bit 03 to output 011, ...
Consumes 2	16...23	Output bits - when the bit is set (1), the output will be turned on. Bit 00 corresponds to output 016, bit 01 corresponds to output 017, bit 02 to output 018, bit 03 to output 019, ...
Consumes 3	24...31	Output bits - when the bit is set (1), the output will be turned on. Bit 00 corresponds to output 024, bit 01 corresponds to output 025, bit 02 to output 026, bit 03 to output 027, ...

Wiring Diagram for Terminal Block

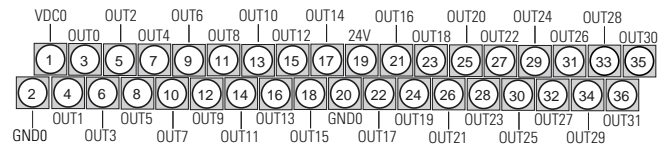

44483

- **Sinking outputs** - wire VDC0 (pin 1) and VDC1 (pin 19) to Field Power (+) 24V dc, wire GND0 (pin 2) and GND1 (pin 20) to Field Power (-) GND.

Module Specifications

1790D-TOV32	
Attribute	Value
Outputs per module	32 points nonisolated, sinking
On-state voltage	10V dc min, 24V dc nom, 28.8V dc max
On-state voltage drop	0.5V dc max
On-state current	1 mA min per channel
Off-state voltage	28.8V dc max
Off-state leakage	0.5 mA max
Output signal delay	Off to On: 0.5 ms max, On to Off: 1.0 ms max
Indicators	32 green status
Output current rating	0.5 A max per output 4.0 A max per common
Common type	16 points/2 COM
General Specifications	
DeviceNet power - base module	Supply voltage - 24V dc nom Voltage range - 11...28.8V dc Power dissipation - 1.2 W max @ 28.8V dc
Field power	Supply voltage - 24V dc nom Voltage range - 10...28.8V dc Power dissipation - 6 mA @ 28.8V dc per point
Isolation	I/O to logic: photocoupler isolation Isolation voltage: 1250V ac rms
Wiring	Terminal block (M3.0) - screw torque: 7 lb-in max (use copper or copper-clad aluminum conductors)

6 Relay Output Base Module (1790D-T0W6)

Simplified Schematic

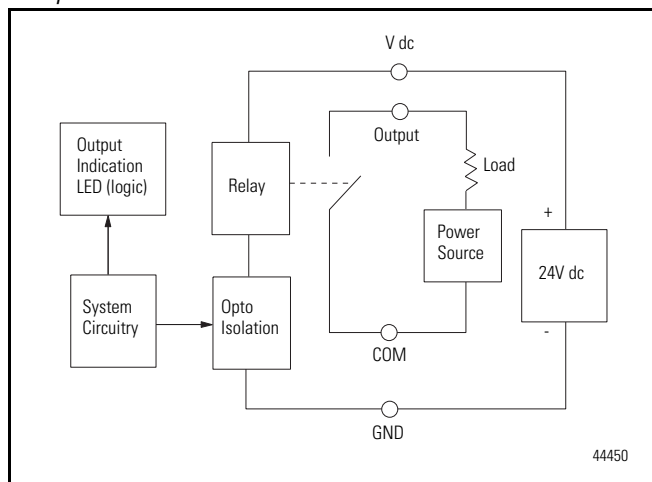

Connection Sizes

Module	I/O Points	Produce (input bytes)	Consume (output bytes)
1790D-T0W6	6 outputs	0 default 1 input with status ⁽¹⁾	1

⁽¹⁾ Available with series B or later.

Word/Bit Definitions

Input with Status Assembly Selected (1790D-T0W6)

Bit	07	06	05	04	03	02	01	00
Produces 0	Status ⁽¹⁾							

⁽¹⁾ Status indicates status of base and expansion modules, **available with series B or later**. There is no specific bit for Status. This byte will be used for "Status" as below:

- 00 (hex) : Normal operation
- 01 (hex) : EEPROM Checksum fault
- 02 (hex) : Too many expansion units
- 03 (hex) : EEPROM parameter not initialized or Serial Number is zero value
- 04 (hex) : First expansion unit changed
- 05 (hex) : Second expansion unit changed
- 06 (hex) : Third expansion unit changed
- 11 (hex) : Rotary S/W changed

Bit	05	04	03	02	01	00
Consumes 0	05	04	03	02	01	00

Word	Bit	Description
Consumes 0	00...06	Output bits - when the bit is set (1), the output will be turned on. Bit 00 corresponds to output 00, bit 01 corresponds to output 01, bit 02 to output 02, bit 03 to output 03, ...

Wiring Diagram for Terminal Block

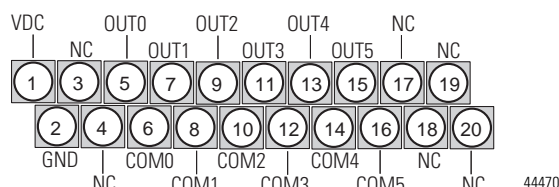

- Wire V dc (pin 1) to Field Power (+) 24V dc.
Wire GND (pin 2) to Field Power (-) GND.

Module Specifications

1790D-T0W6	
Attribute	Value
Relay type	Form A, normally open Single pole, single throw
Output voltage range (load dependent)	5...24V dc @ 2.0 A resistive 30V ac @ 2.0 A resistive 125V ac @ 2.0 A resistive 250V ac @ 2.0 A resistive
Output current rating (at rated power)	2.0 A @ 5...24V dc resistive 2.0 A @ 30V dc resistive
Load, min	100 μ A, 100mV dc per input
On-state voltage drop, max	0.5V @ 2.0 A, resistive load, 24V dc
Initial contact resistance	30 M Ω
Expected contact life	300 Kcycles resistive 100 Kcycles inductive
Off-state leakage, max	1.5 mA max
Output delay time	Off to On: 10 ms max, On to Off: 10 ms max
Indicators	6 green status
Common type	1 point/1COM
General Specifications	
DeviceNet power	Supply voltage - 24V dc nom Voltage range - 11...28.8V dc Power dissipation - 1.2 W max @ 28.8V dc
Field power	Supply voltage - 24V dc nom Voltage range - 19.2...28.8V dc Power dissipation - 10 mA @ 28.8V dc per channel
Isolation	I/O to logic: photocoupler isolation Isolation voltage: 1250V ac rms
Wiring	Terminal block (M3.0) - screw torque: 7 lb-in max (use copper or copper-clad aluminum conductors)

8 Relay Output Expansion Module (1790-TOW8X)

Simplified Schematic

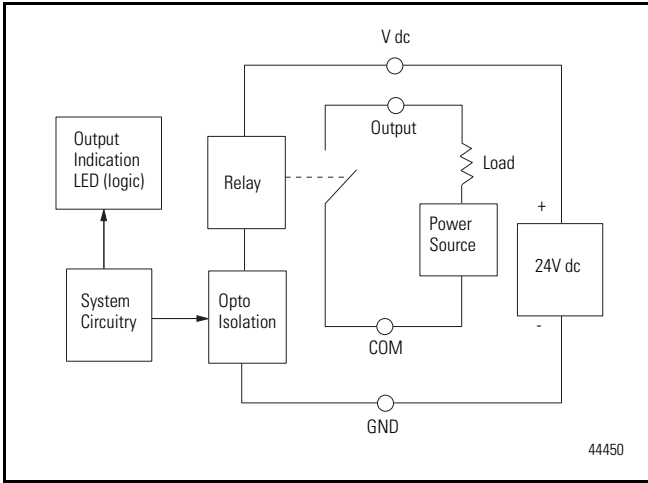

Connection Sizes

Module	I/O Points	Produce (input bytes)	Consume (output bytes)
1790-TOW8X	8 outputs	0	1

Word/Bit Definitions

Bit	07	06	05	04	03	02	01	00
Consumes 0	07	06	05	04	03	02	01	00

Word	Bit	Description
Consumes 0	00...08	Output bits - when the bit is set (1), the output will be turned on. Bit 00 corresponds to output 00, bit 01 corresponds to output 01, bit 02 to output 02, bit 03 to output 03, ...

Wiring Diagram for Terminal Block

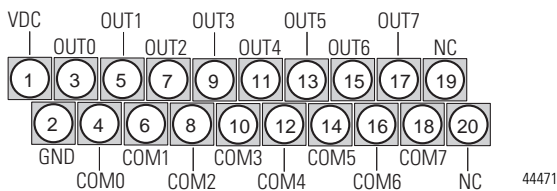

- Wire V dc (pin 1) to Field Power (+) 24V dc.
Wire GND (pin 2) to Field Power (-) GND.

Module Specifications

1790-TOW8X	
Attribute	Value
Relay type	Form A, normally open Single pole, single throw
Output voltage range (load dependent)	5...28V dc @ 2.0 A resistive 48V ac @ 0.8 A resistive 125V ac @ 2.0 A resistive 250V ac @ 2.0 A resistive
Load, min	100 μ A, 100mV dc per input
On-state voltage drop, max	0.5V @ 2.0 A, resistive load, 24V dc
Initial contact resistance	30 m Ω
Expected contact life	300 Kcycles resistive 100 Kcycles inductive
Off-state leakage, max	1.5 mA max
Output delay time	Off to On: 10 ms max, On to Off: 10 ms max
Indicators	8 green status
Common type	1 point/1COM
General Specifications	
Field power	Supply voltage - 24V dc nom Voltage range - 19.2...28.8V dc Power dissipation - 2.3W @ 28.8V dc per channel
Isolation	I/O to logic: photocoupler isolation Isolation voltage: 1250V ac rms
Wiring	Terminal block (M3.0) - screw torque: 7 lb-in max (use copper or copper-clad aluminum conductors)

24V dc 16 Universal Input Base and Expansion Modules (1790D-T16BV0 and 1790-T16BV0X)

Simplified Schematic

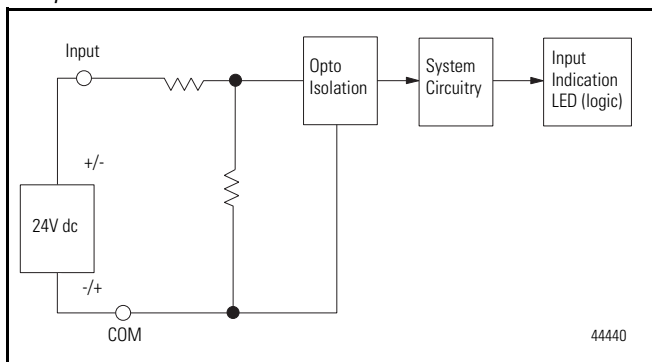

Connection Sizes

Modules	I/O Points	Produce (input bytes)	Consume (output bytes)
1790D-T16BV0, 1790-T16BV0X	16 inputs	2 default 3 input with status ⁽¹⁾	0

⁽¹⁾ Available with series B or later.

Word/Bit Definitions

Default (1790D-T16BV0 and 1790-T16BV0X)								
Bit	07	06	05	04	03	02	01	00
Produces 0	I7	I6	I5	I4	I3	I2	I1	I0
Produces 1	I15	I14	I13	I12	I11	I10	I9	I8

Word	Bit	Description
Produces 0	00...07	Input Status bits - when the bit is set (1), the input is on. Bit 00 corresponds to input I0, bit 01 corresponds to input I1, bit 02 corresponds to input I2, bit 03 corresponds to input I3, ...
Produces 1	08...15	Input Status bits - when the bit is set (1), the input is on. Bit 00 corresponds to input I8, bit 01 corresponds to input I9, bit 02 corresponds to input I10, bit 03 corresponds to input I11, ...

Inputs with Status Assembly Selected (1790D-T16BV0)								
Bit	07	06	05	04	03	02	01	00
Produces 0	Status ⁽¹⁾							
Produces 1	I15	I14	I13	I12	I11	I10	I9	I8
Produces 2	I16	I15	I14	I13	I12	I11	I10	I9

⁽¹⁾ Status indicates status of base and expansion modules, **available with series B or later**. There is no specific bit for Status. This byte will be used for "Status" as below:

1. 00 (hex) : Normal operation
2. 01 (hex) : EEPROM Checksum fault
3. 02 (hex) : Too many expansion units
4. 03 (hex) : EEPROM parameter not initialized or Serial Number is zero value
5. 04 (hex) : First expansion unit changed
6. 05 (hex) : Second expansion unit changed
7. 06 (hex) : Third expansion unit changed
8. 11 (hex) : Rotary S/W changed

Word	Bit	Description
Produces 0	00...07	Status byte
Produces 0	08...15	Input Status bits - when the bit is set (1), the input is on. Bit 00 corresponds to input I0, bit 01 corresponds to input I1, bit 02 corresponds to input I2, bit 03 corresponds to input I3, ...
Produces 1	16...23	Input Status bits - when the bit is set (1), the input is on. Bit 00 corresponds to input I8, bit 01 corresponds to input I9, bit 02 corresponds to input I10, bit 03 corresponds to input I11, ...

Wiring Diagram for Terminal Block

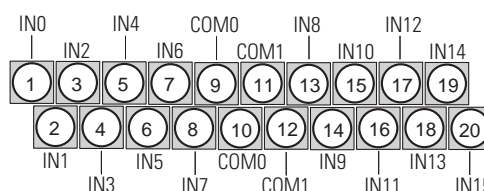

44463

- **For inputs 0...7: Sinking inputs** - wire COM 0 (pin 9) to Field Power (-) GND.
Sourcing inputs - wire COM 0 (pin 9) to Field Power (+) 24V dc.
- **For inputs 8...15: Sinking inputs** - wire COM 1 (pin 11) to Field Power (-) GND.
Sourcing inputs - wire COM 1 (pin 11) to Field Power (+) 24V dc
Note that both COM 0 are internally connected - COM 0 is used for inputs 0-7, COM 1 is used for inputs 8-15. Both COM 1 are internally connected.

Module Specifications

1790D-T16BVO and 1790-TBV0X	
Attribute	Value
Inputs per module	16 points, sinking or sourcing
On-state voltage	9.6V dc min, 24V dc nom, 28.8V dc max
Off-state voltage	5.0V dc max
On-state current	8 mA max per channel @ 28.8V dc
Input impedance, nom	4.8 K Ω
Indicators	16 green input status
Common type	8 points/8COM (non-polarity)
General Specifications	
DeviceNet power - base module	Supply voltage - 24V dc nom Voltage range - 11...28.8V dc Power dissipation - 1.2 W max @ 28.8V dc
Isolation	I/O to logic: photocoupler isolation Isolation voltage: 1250V ac rms DeviceNet to logic: nonisolated DeviceNet power: nonisolated
Wiring	Terminal block (M3.0) - screw torque: 7 lb-in max (use copper or copper-clad aluminum conductors)

24V dc 32 Universal Input Base Module (1790D-T32BV0)

Simplified Schematic

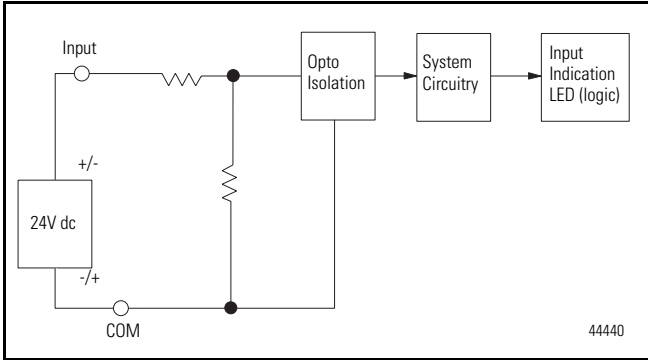

Connection Sizes

Modules	I/O Points	Produce (input bytes)	Consume (output bytes)
1790D-T32BV0	32 inputs	4 default 5 inputs with status	0

Word/Bit Definitions

Default (1790D-T32BV0)								
Bit	07	06	05	04	03	02	01	00
Produces 0	I17	I16	I15	I14	I13	I12	I11	I10
Produces 1	I115	I114	I113	I112	I111	I110	I109	I108
Produces 2	I123	I122	I121	I120	I119	I118	I117	I116
Produces 3	I131	I130	I129	I128	I127	I126	I125	I124

Word	Bit	Description
Produces 0	00...07	Input Status bits - when the bit is set (1), the input is on. Bit 00 corresponds to input I0, bit 01 corresponds to input I1, bit 02 corresponds to input I2, bit 03 corresponds to input I3, ...
Produces 1	08...15	Input Status bits - when the bit is set (1), the input is on. Bit 00 corresponds to input I8, bit 01 corresponds to input I9, bit 02 corresponds to input I10, bit 03 corresponds to input I11, ...
Produces 2	16...23	Input Status bits - when the bit is set (1), the input is on. Bit 00 corresponds to input I16, bit 01 corresponds to input I17, bit 02 corresponds to input I18, bit 03 corresponds to input I19, ...
Produces 3	24...31	Input Status bits - when the bit is set (1), the input is on. Bit 00 corresponds to input I24, bit 01 corresponds to input I25, bit 02 corresponds to input I26, bit 03 corresponds to input I27, ...

Inputs with Status Assembly Selected (1790D-T32BV0)

Bit	07	06	05	04	03	02	01	00
Produces 0	Status ⁽¹⁾							
Produces 1	I115	I114	I113	I112	I111	I110	I109	I108
Produces 2	I123	I122	I121	I120	I119	I118	I117	I116
Produces 3	I131	I130	I129	I128	I127	I126	I125	I124
Produces 4	I139	I138	I137	I136	I135	I134	I133	I132

- (1) Status indicates status of base and expansion modules, **available with series B or later**. There is no specific bit for Status. This byte will be used for "Status" as below:
- 00 (hex) : Normal operation
 - 01 (hex) : EEPROM Checksum fault
 - 02 (hex) : Too many expansion units
 - 03 (hex) : EEPROM parameter not initialized or Serial Number is zero value
 - 04 (hex) : First expansion unit changed
 - 05 (hex) : Second expansion unit changed
 - 06 (hex) : Third expansion unit changed
 - 11 (hex) : Rotary S/W changed

Word	Bit	Description
Produces 0	00...07	Status byte
Produces 1	08...15	Input Status bits - when the bit is set (1), the input is on. Bit 00 corresponds to input I0, bit 01 corresponds to input I1, bit 02 corresponds to input I2, bit 03 corresponds to input I3, ...
Produces 2	16...23	Input Status bits - when the bit is set (1), the input is on. Bit 00 corresponds to input I8, bit 01 corresponds to input I9, bit 02 corresponds to input I10, bit 03 corresponds to input I11, ...
Produces 3	24...31	Input Status bits - when the bit is set (1), the input is on. Bit 00 corresponds to input I16, bit 01 corresponds to input I17, bit 02 corresponds to input I18, bit 03 corresponds to input I19, ...
Produces 4	32...39	Input Status bits - when the bit is set (1), the input is on. Bit 00 corresponds to input I24, bit 01 corresponds to input I25, bit 02 corresponds to input I26, bit 03 corresponds to input I27, ...

Wiring Diagram for Terminal Block

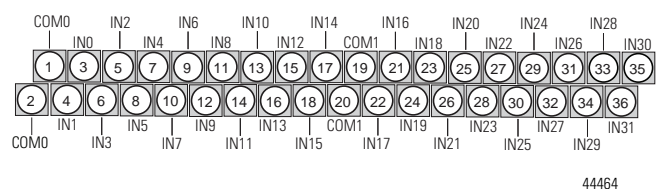

- **For inputs 0...15: Sinking inputs** - wire COM0 (pin 1) to Field Power (-) GND.
- **Sourcing inputs** - wire COM0 (pin 1) to Field Power (+) 24V dc. Note that both COM0 (pins 1 and 2) are internally connected.

- **For inputs 16...31: Sinking inputs** - wire COM1 (pin 19) to Field Power (-) GND.
Sourcing inputs - wire COM1 (pin 19) to Field Power (+) 24V dc.
 Note that both COM1 (pins 19 and 20) are internally connected.

Module Specifications

1790D-T32BV0	
Attribute	Value
Inputs per module	32 points, sinking or sourcing
On-state voltage	9.6V dc min, 24V dc nom, 28.8V dc max
Off-state voltage	5.0V dc max
On-state current	8 mA max per channel @ 28.8V dc
Input impedance, nom	4.8 K Ω
Indicators	32 green input status
Common type	16 points/4COM (non-polarity)
General Specifications	
DeviceNet power - base module	Supply voltage - 24V dc nom Voltage range - 11...28.8V dc Power dissipation - 1.2 W max @ 28.8V dc
Isolation	I/O to logic: photocoupler isolation Isolation voltage: 1250V ac rms DeviceNet to logic: nonisolated DeviceNet power: nonisolated
Wiring	Terminal block (M3.0) - screw torque: 7 lb-in max (use copper or copper-clad aluminum conductors)

120V ac 8 Input Base and Expansion Modules (1790D-T8A0 and 1790-T8A0X)

Simplified Schematic

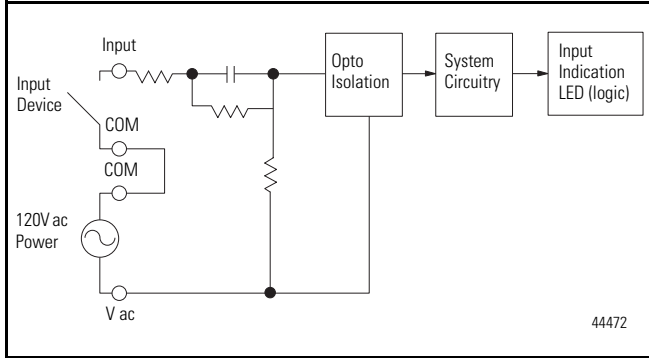

Connection Sizes

Modules	I/O Points	Produce (input bytes)	Consume (output bytes)
1790D-T8A0 and 1790-T8A0X	8 inputs	1 default 2 inputs with status ⁽¹⁾	0

⁽¹⁾ Available with series B or later.

Word/Bit Definitions

Default (1790D-T8A0 and 1790-T8A0X)								
Bit	07	06	05	04	03	02	01	00
Produces 0	I7	I6	I5	I4	I3	I2	I1	I0

Word	Bit	Description
Produces 0	00...07	Input bits - when the bit is set (1), the input will be turned on. Bit 00 corresponds to input I0, bit 01 corresponds to input I1, bit 02 to input I2, bit 03 to input I3, ...

Inputs with Status Assembly Selected (1790D-T8A0, 1790-T8A0X)								
Bit	07	06	05	04	03	02	01	00
Produces 0	Status ⁽¹⁾							
Produces 1	I15	I14	I13	I12	I11	I10	I9	I8

- ⁽¹⁾ Status indicates status of base and expansion modules, **available with series B or later**. There is no specific bit for Status. This byte will be used for "Status" as below:
- 00 (hex) : Normal operation
 - 01 (hex) : EEPROM Checksum fault
 - 02 (hex) : Too many expansion units
 - 03 (hex) : EEPROM parameter not initialized or Serial Number is zero value
 - 04 (hex) : First expansion unit changed
 - 05 (hex) : Second expansion unit changed
 - 06 (hex) : Third expansion unit changed
 - 11 (hex) : Rotary S/W changed

Word	Bit	Description
Produces 0	00...07	Status byte
Produces 1	08...15	Input bits - when the bit is set (1), the input will be turned on. Bit 00 corresponds to input I0, bit 01 corresponds to input I1, bit 02 to input I2, bit 03 to input I3, ...

Wiring Diagram for Terminal Block

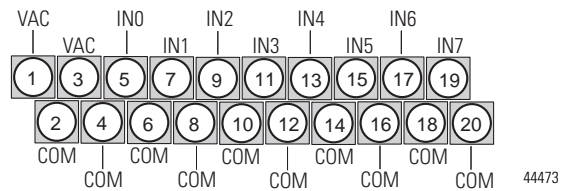

- Wire 120V ac Field Power to V ac (pin 1) and COM (pin 2). Note that all V ac are internally connected. All COM are internally connected.

Module Specifications

1790D-T8AO and 1790-T8AOX	
Attribute	Value
Inputs per module	8 points nonisolated
On-state voltage range	85V ac min 110V ac nom 132V ac max
Input impedance	18 k Ω
On-state current	9 mA max @ 132V ac
Off-state voltage	45V ac max
Input signal delay	Off to On: 10 ms, On to Off: 30 ms
Indicators	8 green input status
Common type	8 points/8 COM
General Specifications	
DeviceNet power - base module	Supply voltage - 24V dc nom Voltage range - 11...28.8V dc Power dissipation - 1.2 W max @ 28.8V dc
External AC power supply	Supply voltage - 110V rms, 60 Hz Voltage range - 85...32V rms, 47...63 Hz Power dissipation - 3 W @ 132V ac
Isolation	I/O to logic: photocoupler isolation Isolation voltage: 1250V ac rms/V ac Field power: non-isolation
Wiring	Terminal block (M3.0) - screw torque: 7 lb-in max (use copper or copper-clad aluminum conductors)
Recommended fusing	1 A, 250V, normal blow

24V dc 8 Universal Input/8 Sourcing Output Base and Expansion Modules (1790D-T8BV8B and 1790-T8BV8BX)

Simplified Schematic

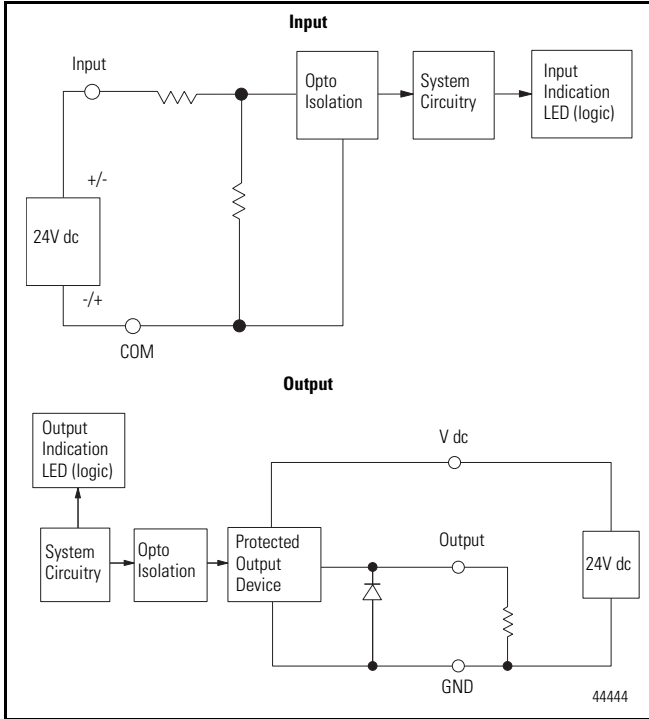

Connection Sizes

Modules	I/O Points	Produce (input bytes)	Consume (output bytes)
1790D-T8BV8B, 1790-T8BV8BX	8 input / 8 output	1 default 2 inputs with status ⁽¹⁾	1

⁽¹⁾ Available with series B or later.

Word/Bit Definitions

Default (1790D-T8BV8B and 1790-T8BV8BX)								
Bit	07	06	05	04	03	02	01	00
Produces 0	17	16	15	14	13	12	11	10

Word	Bit	Description
Produces 0	00...07	Input Status bits - when the bit is set (1), the input is on. Bit 00 corresponds to input I0, bit 01 corresponds to input I1, bit 02 corresponds to input I2, bit 03 corresponds to input I3, ...

Inputs with Status Assembly Selected (1790D-T8BV8B)								
Bit	07	06	05	04	03	02	01	00
Produces 0	Status ⁽¹⁾							
Produces 1	I15	I14	I13	I12	I11	I10	I9	I8

⁽¹⁾ Status indicates status of base and expansion modules, **available with series B or later**. There is no specific bit for Status. This byte will be used for "Status" as below:

1. 00 (hex) : Normal operation
2. 01 (hex) : EEPROM Checksum fault
3. 02 (hex) : Too many expansion units
4. 03 (hex) : EEPROM parameter not initialized or Serial Number is zero value
5. 04 (hex) : First expansion unit changed
6. 05 (hex) : Second expansion unit changed
7. 06 (hex) : Third expansion unit changed
8. 11 (hex) : Rotary S/W changed

Word	Bit	Description
Produces 0	00...07	Status byte
Produces 1	08...15	Input Status bits - when the bit is set (1), the input is on. Bit 00 corresponds to input I0, bit 01 corresponds to input I1, bit 02 corresponds to input I2, bit 03 corresponds to input I3, ...

Bit	07	06	05	04	03	02	01	00
Consumes	07	06	05	04	03	02	01	00

Word	Bit	Description
Consumes	00...07	Output bits - when the bit is set (1), the output is on. Bit 00 corresponds to output O0, bit 01 corresponds to output O1, bit 02 to output O2, bit 03 to output O3, ...

Wiring Diagram for Terminal Block

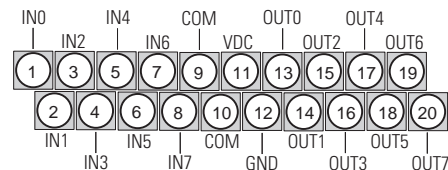

- **Sinking inputs** - wire COM (pin 9) to Field Power (-) GND.
- **Sourcing inputs** - wire COM (pin 9) to Field Power (+) 24V dc. Note that both COM (pins 9 and 10) are internally connected.
- **Sourcing outputs** - wire V dc (pin 11) to Field Power (+) 24V dc, wire GND (pin 12) to Field Power (-) GND.

Module Specifications

1790D-T8BV8B, 1790-T8BV8BX	
Input Specifications	
Attribute	Value
Inputs per module	8 points nonisolated, sinking or sourcing
On-state voltage	9.6V dc min 24V dc nom 28.8V dc max
On-state current	8 mA max per point @ 28.8V dc
Off-state voltage	5V dc max
Input impedance, nom	4.8 K Ω
Indicators	8 green status
Common type	8 points/8COM (non-polarity)
Output Specifications	
Outputs per module	8 points nonisolated, sourcing
On-state voltage	10V dc min 24V dc nom 28.8V dc max
On-state voltage drop	0.5V dc max
On-state current	1 mA min per channel
Off-state leakage	0.5 mA max
Output signal delay	Off to On: 0.5 ms max, On to Off: 1.0 ms max
Indicators	8 green status
Output current rating	0.5 A max per output, 4.0 A max per common
Common type	8 points/8COM (1790D-8BV8B)
General Specifications	
DeviceNet power - base module	Supply voltage - 24V dc nom Voltage range - 11...28.8V dc Power dissipation - 1.2 W max @ 28.8V dc
Field power	Supply voltage - 24V dc nom Voltage range - 10...28.8V dc Power dissipation - 6 mA @ 28.8V dc per point
Isolation	I/O to logic: photocoupler isolation Isolation voltage: 1250V ac rms DeviceNet to logic: nonisolated DeviceNet power: nonisolated
Wiring	Terminal block (M3.0) - screw torque: 7 lb-in max (use copper or copper-clad aluminum conductors)

24V dc 16 Universal Input/16 Sourcing Output Base Module (1790D-T16BV16B)

Simplified Schematic

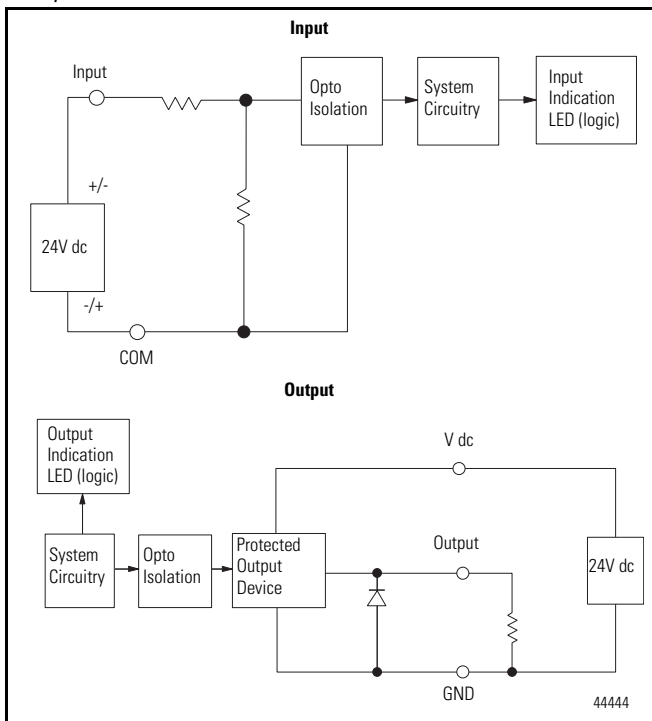

Connection Sizes

Modules	I/O Points	Produce (input bytes)	Consume (output bytes)
1790D-T16BV16B	16 inputs/ 16 outputs	2 default 3 inputs with status ⁽¹⁾	2

⁽¹⁾ Available with series B or later.

Word/Bit Definitions

Default (1790D-T16BV16B)

Bit	07	06	05	04	03	02	01	00
Produces 0	I7	I6	I5	I4	I3	I2	I1	I0
Produces 1	I15	I14	I13	I12	I11	I10	I9	I8

Word	Bit	Description
Produces 0	00...07	Input Status bits - when the bit is set (1), the input is on. Bit 00 corresponds to input I0, bit 01 corresponds to input I1, bit 02 corresponds to input I2, bit 03 corresponds to input I3, ...
Produces 1	08...15	Input Status bits - when the bit is set (1), the input is on. Bit 00 corresponds to input I8, bit 01 corresponds to input I9, bit 02 corresponds to input I10, bit 03 corresponds to input I11, ...

Inputs with Status Assembly Selected (1790D-T16BV16B)

Bit	07	06	05	04	03	02	01	00
Produces 0	Status ⁽¹⁾							
Produces 1	I15	I14	I13	I12	I11	I10	I9	I8
Produces 2	I23	I22	I21	I20	I19	I18	I17	I16

⁽¹⁾ Status indicates status of base and expansion modules, **available with series B or later**. There is no specific bit for Status. This byte will be used for "Status" as below:

1. 00 (hex) : Normal operation
2. 01 (hex) : EEPROM Checksum fault
3. 02 (hex) : Too many expansion units
4. 03 (hex) : EEPROM parameter not initialized or Serial Number is zero value
5. 04 (hex) : First expansion unit changed
6. 05 (hex) : Second expansion unit changed
7. 06 (hex) : Third expansion unit changed
8. 11 (hex) : Rotary S/W changed

Word	Bit	Description
Produces 0	00...07	Status byte
Produces 1	08...15	Input Status bits - when the bit is set (1), the input is on. Bit 00 corresponds to input I0, bit 01 corresponds to input I1, bit 02 corresponds to input I2, bit 03 corresponds to input I3, ...
Produces 2	16...23	Input Status bits - when the bit is set (1), the input is on. Bit 00 corresponds to input I8, bit 01 corresponds to input I9, bit 02 corresponds to input I10, bit 03 corresponds to input I11, ...

Bit	07	06	05	04	03	02	01	00
Consumes 0	O7	O6	O5	O4	O3	O2	O1	O0
Consumes 1	O15	O14	O13	O12	O11	O10	O9	O8

Word	Bit	Description
Consumes 0	00...07	Output bits - when the bit is set (1), the output is on. Bit 00 corresponds to output O0, bit 01 corresponds to output O1, bit 02 to output O2, bit 03 to output O3, ...
Consumes 1	08...15	Output bits - when the bit is set (1), the output is on. Bit 00 corresponds to output O8, bit 01 corresponds to output O9, bit 02 to output O10, bit 03 to output O11, ...

Wiring Diagram for Terminal Block

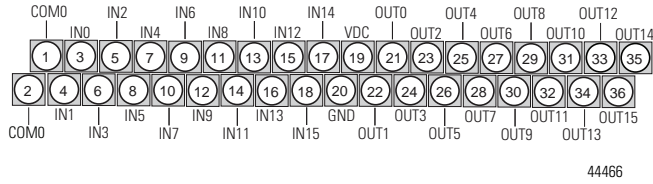

44466

- **Sinking inputs** - wire COM (pin 1) to Field Power (-) GND.
- **Sourcing inputs** - wire COM (pin 1) to Field Power (+) 24V dc. Note that both COM (pins 1 and 2) are internally connected.
- **Sourcing outputs** - wire V dc (pin 19) to Field Power (+) 24V dc, wire GND (pin 20) to Field Power (-) GND.

Module Specifications

1790D-T16BV16B	
Input Specifications	
Attribute	Value
Inputs per module	16 points nonisolated, sinking or sourcing
On-state voltage	9.6V dc min 24V dc nom 28.8V dc max
On-state current	8 mA max per point @ 28.8V dc
Off-state voltage	5V dc max
Input impedance, nom	4.8 KΩ
Indicators	16 green status
Common type	16 points/16COM (non-polarity)
Output Specifications	
Outputs per module	16 points nonisolated, sourcing
On-state voltage	10V dc min 24V dc nom 28.8V dc max
On-state voltage drop	0.5V dc max
On-state current	1 mA min per channel
Off-state leakage	0.5 mA max
Output signal delay	Off to On: 0.5 ms max, On to Off: 1.0 ms max
Indicators	16 green status
Output current rating	0.5 A max per output, 4.0 A max per common
Common type	16 points/16COM
General Specifications	
DeviceNet power - base module	Supply voltage - 24V dc nom Voltage range - 11...28.8V dc Power dissipation - 1.2 W max @ 28.8V dc
Field power	Supply voltage - 24V dc nom Voltage range - 10...28.8V dc Power dissipation - 6 mA @ 28.8V dc per point
Isolation	I/O to logic: photocoupler isolation Isolation voltage: 1250V ac rms DeviceNet to logic: nonisolated DeviceNet power: nonisolated
Wiring	Terminal block (M3.0) - screw torque: 7 lb-in max (use copper or copper-clad aluminum conductors)

24V dc 8 Universal Input/8 Sinking Output Base and Expansion Modules (1790D-T8BV8V and 1790-T8BV8VX)

Simplified Schematic

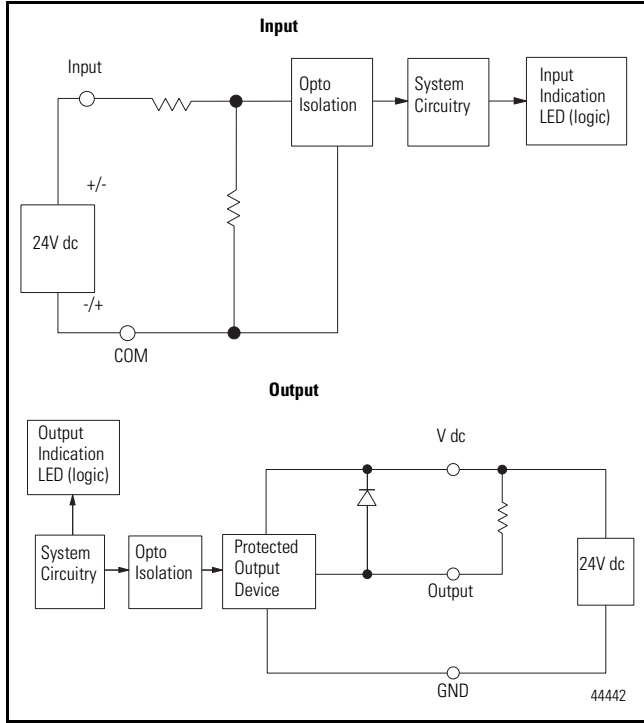

Connection Sizes

Modules	I/O Points	Produce (input bytes)	Consume (output bytes)
1790D-T8BV8V and 1790-T8BV8VX	8 input / 8 output	1 default 2 inputs with status ⁽¹⁾	1

⁽¹⁾ Available with series B or later.

Word/Bit Definitions

Default (1790D-T8BV8V and 1790-T8BV8VX)

Bit	07	06	05	04	03	02	01	00
Produces 0	I7	I6	I5	I4	I3	I2	I1	I0

Word	Bit	Description
Produces 0	00...07	Input Status bits - when the bit is set (1), the input is on. Bit 00 corresponds to input I0, bit 01 corresponds to input I1, bit 02 corresponds to input I2, bit 03 corresponds to input I3, ...

Inputs with Status Assembly Selected (1790D-T8BV8V)								
Bit	07	06	05	04	03	02	01	00
Produces 0	Status ⁽¹⁾							
Produces 1	I15	I14	I13	I12	I11	I10	I9	I8

- ⁽¹⁾ Status indicates status of base and expansion modules, **available with series B or later**. There is no specific bit for Status. This byte will be used for "Status" as below:
- 00 (hex) : Normal operation
 - 01 (hex) : EEPROM Checksum fault
 - 02 (hex) : Too many expansion units
 - 03 (hex) : EEPROM parameter not initialized or Serial Number is zero value
 - 04 (hex) : First expansion unit changed
 - 05 (hex) : Second expansion unit changed
 - 06 (hex) : Third expansion unit changed
 - 11 (hex) : Rotary S/W changed

Word	Bit	Description
Produces 0	00...07	Status byte
Produces 1	08...15	Input Status bits - when the bit is set (1), the input is on. Bit 00 corresponds to input I0, bit 01 corresponds to input I1, bit 02 corresponds to input I2, bit 03 corresponds to input I3, ...

Bit	07	06	05	04	03	02	01	00
Consumes	O7	O6	O5	O4	O3	O2	O1	O0

Word	Bit	Description
Consumes	00...07	Output bits - when the bit is set (1), the output is on. Bit 00 corresponds to output O0, bit 01 corresponds to output O1, bit 02 to output O2, bit 03 to output O3, ...

Wiring Diagram for Terminal Block

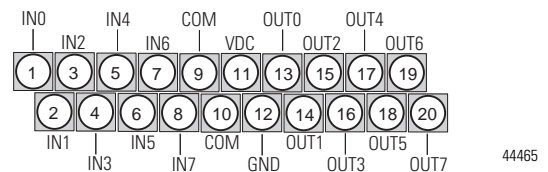

- Sinking inputs** - wire COM (pin 9) to Field Power (-) GND.
- Sourcing inputs** - wire COM (pin 9) to Field Power (+) 24V dc. Note that both COM (pins 9 and 10) are internally connected.
- Sinking outputs** - wire V dc (pin 11) to Field Power (+) 24V dc, wire GND (pin 12) to Field Power (-) GND.

Module Specifications

1790D-T8BV8V and 1790-T8BV8VX	
Input Specifications	
Attribute	Value
Inputs per block	8 points nonisolated, sinking or sourcing
On-state voltage	9.6V dc min 24V dc nom 28.8V dc max
On-state current	8 mA max per point @ 28.8V dc
Off-state voltage	5V dc max
Input impedance, nom	4.8 K Ω
Indicators	8 green status
Common type	8 points/8 COM (non-polarity)
Output Specifications	
Outputs per block	8 points nonisolated, sinking
On-state voltage	10V dc min, 24V dc nom, 28.8V dc max
On-state voltage drop	0.5V dc max
On-state current	1 mA min per channel
Off-state leakage	0.5 mA max
Output signal delay	Off to On: 0.5 ms max, On to Off: 1.0 ms max
Indicators	8 green status
Output current rating	0.5 max A per output, 4.0 A max per common
Common type	8 points/8 COM
General Specifications	
DeviceNet power - base block	Supply voltage - 24V dc nom Voltage range - 11...28.8V dc Power dissipation - 1.2 W max @ 28.8V dc
Field power	Supply voltage - 24V dc nom Voltage range - 10...28.8V dc Power dissipation - 6 mA @ 28.8V dc per point
Isolation	I/O to logic: photocoupler isolation Isolation voltage: 1250V ac rms DeviceNet to logic: nonisolated DeviceNet power: nonisolated
Wiring	Terminal block (M3.0) - screw torque: 7 lb-in max (use copper or copper-clad aluminum conductors)

24V dc 16 Universal Input/16 Sinking Output Base Module (1790D-T16BV16V)

Simplified Schematic

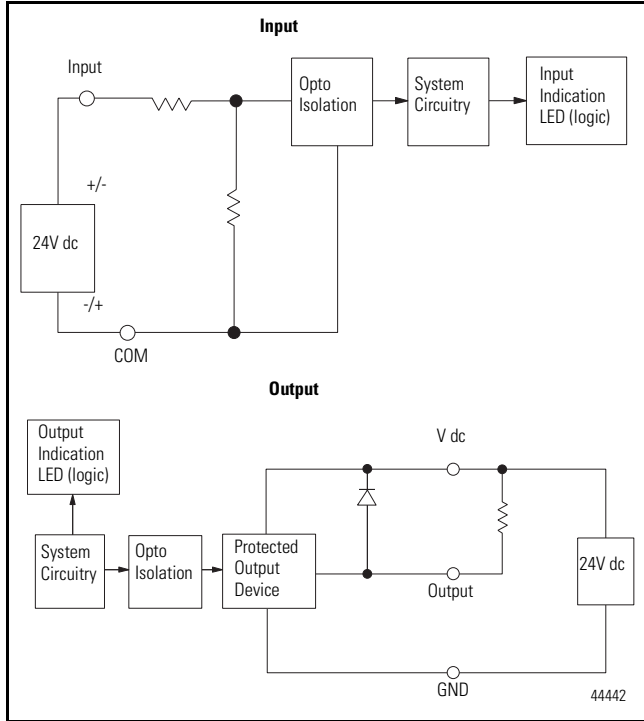

Connection Sizes

Modules	I/O Points	Produce (input bytes)	Consume (output bytes)
1790D-T16BV16V	16 input / 16 output	2 default 3 inputs with status	2

Word/Bit Definitions

Default (1790D-T16BV16V)								
Bit	07	06	05	04	03	02	01	00
Produces 0	I7	I6	I5	I4	I3	I2	I1	I0
Produces 1	I15	I14	I13	I12	I11	I10	I9	I8

Word	Bit	Description
Produces 0	00...07	Input Status bits - when the bit is set (1), the input is on. Bit 00 corresponds to input I0, bit 01 corresponds to input I1, bit 02 corresponds to input I2, bit 03 corresponds to input I3, ...
Produces 1	15...08	Input Status bits - when the bit is set (1), the input is on. Bit 00 corresponds to input I8, bit 01 corresponds to input I9, bit 02 corresponds to input I10, bit 03 corresponds to input I11, ...

Inputs with Status Assembly Selected (1790D-T16BV16V)								
Bit	07	06	05	04	03	02	01	00
Produces 0	Status ⁽¹⁾							
Produces 1	I15	I14	I13	I12	I11	I10	I9	I8
Produces 2	I23	I22	I21	I20	I19	I18	I17	I16

- ⁽¹⁾ Status indicates status of base and expansion modules, **available with series B or later**. There is no specific bit for Status. This byte will be used for "Status" as below:
- 00 (hex) : Normal operation
 - 01 (hex) : EEPROM Checksum fault
 - 02 (hex) : Too many expansion units
 - 03 (hex) : EEPROM parameter not initialized or Serial Number is zero value
 - 04 (hex) : First expansion unit changed
 - 05 (hex) : Second expansion unit changed
 - 06 (hex) : Third expansion unit changed
 - 11 (hex) : Rotary S/W changed

Word	Bit	Description
Produces 0	00...07	Status byte
Produces 1	07...15	Input Status bits - when the bit is set (1), the input is on. Bit 00 corresponds to input I0, bit 01 corresponds to input I1, bit 02 corresponds to input I2, bit 03 corresponds to input I3, ...
Produces 2	16...23	Input Status bits - when the bit is set (1), the input is on. Bit 00 corresponds to input I8, bit 01 corresponds to input I9, bit 02 corresponds to input I10, bit 03 corresponds to input I11, ...

Bit	07	06	05	04	03	02	01	00
Consumes 0	O7	O6	O5	O4	O3	O2	O1	O0
Consumes 1	O15	O14	O13	O12	O11	O10	O9	O8

Word	Bit	Description
Consumes 0	00...07	Output bits - when the bit is set (1), the output is on. Bit 00 corresponds to output O0, bit 01 corresponds to output O1, bit 02 to output O2, bit 03 to output O3, ...
Consumes 1	08...15	Output bits - when the bit is set (1), the output is on. Bit 00 corresponds to output O8, bit 01 corresponds to output O9, bit 02 to output O10, bit 03 to output O11, ...

Wiring Diagram for Terminal Block

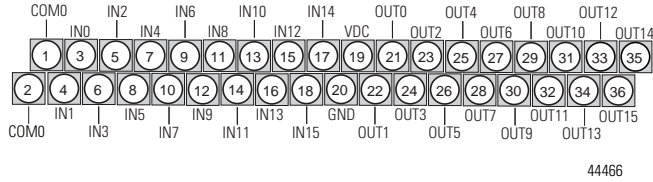

- **Sinking inputs** - wire COM (pin 1) to Field Power (-) GND.
- **Sourcing inputs** - wire COM (pin 1) to Field Power (+) 24V dc. Note that both COM (pins 1 and 2) are internally connected.
- **Sourcing outputs** - wire V dc (pin 19) to Field Power (+) 24V dc, wire GND (pin 20) to Field Power (-) GND.

Module Specifications

1790D-T16BV16V	
Input Specifications	
Attribute	Value
Inputs per module	16 points nonisolated, sinking or sourcing
On-state voltage	9.6V dc min 24V dc nom 28.8V dc max
On-state current	8 mA max per point @ 28.8V dc
Off-state voltage	5V dc max
Input impedance, nom	4.8 KΩ
Indicators	16 green status
Common type	16 points/16 COM (non-polarity)
Output Specifications	
Outputs per module	16 points nonisolated, sinking
On-state voltage	10V dc min, 24V dc nom, 28.8V dc max
On-state voltage drop	0.5V dc max
On-state current, min	1 mA per channel
On-state current, max	8 mA min per channel @ 28.8V
Off-state leakage	0.5 mA max
Output signal delay	Off to On: 0.5 ms max, On to Off: 1.0 ms max
Indicators	16 green status
Output current rating	0.5 max A per output, 4.0 A max per common
Common type	16 points/16 COM
General Specifications	
DeviceNet power - base module	Supply voltage - 24V dc nom Voltage range - 11...28.8V dc Power dissipation - 1.2 W max @ 28.8V dc
Field power	Supply voltage - 24V dc nom Voltage range - 10...28.8V dc Power dissipation - 3.22 W @ 28.8V dc
Isolation	I/O to logic: photocoupler isolation Isolation voltage: 1250V ac rms DeviceNet to logic: nonisolated DeviceNet power: nonisolated
Wiring	Terminal block (M3.0) - screw torque: 7 lb-in max (use copper or copper-clad aluminum conductors)

4 Channel Input RTD Base Module (1790D-T4R0)

Simplified Schematic

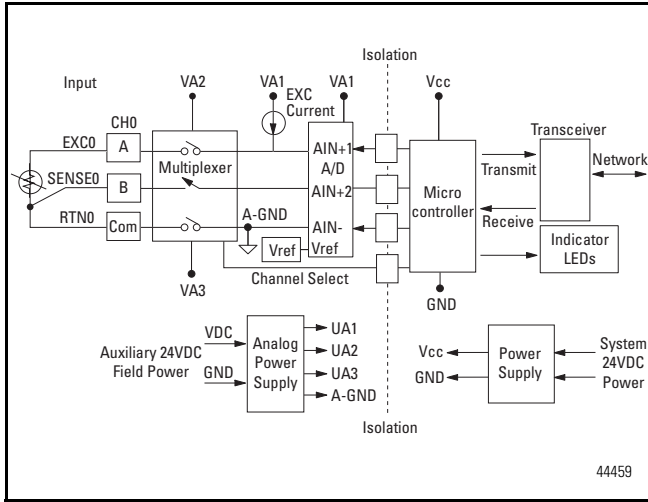

Input Data File

Word	Bit Position																
	15	14	13	12	11	10	9	8	7	6	5	4	3	2	1	0	
0	RTD Input Data Channel 0																
1	RTD Input Data Channel 1																
2	RTD Input Data Channel 2																
3	RTD Input Data Channel 3																
4	Not Used			S11	S10	S9	S8	Not Used			S3	S2	S1	S0			

Wiring Diagram for Terminal Block

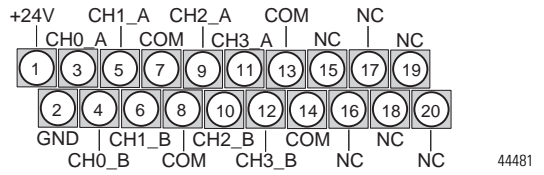

- Wire pin 1 to Field Power (+) 24V dc.
Wire pin 2 to Field Power (-) GND.

Connection Sizes

Module	I/O Points	Produce (input bytes)	Consume (output bytes)
1790D-T4R0	4 channel	10	0

Word/Bit Definitions

Word	Decimal Bit	Description
Read Word 0	Bits 00...15	Channel 0 input data
Read Word 1	Bits 00...15	Channel 1 input data
Read Word 2	Bits 00...15	Channel 2 input data
Read Word 3	Bits 00...15	Channel 3 input data
Read Word 4	Bits 00...03	Underrange for individual channels - Bit 00 corresponds to input channel 0, bit 01 corresponds to input channel 1, ... When set (1) the input signal is below the input channel's minimum range.
	Bits 04...07	Not used: Set to 0
	Bits 08...11	Overrange for individual channels - Bit 08 corresponds to input channel 0, bit 09 corresponds to input channel 1 When set (1) the input signal is above the input channel's maximum range, or open RTD is detected.
	Bits 12...15	Not used: Set to 0

Module Specifications

1790D-T4R0				
Attribute	Value			
Inputs per module	4 channel, RTD/Resistance Input			
Input range	1...625 Ω			
Sensors supported	Sensor Type	Degree	Counts	Resolution
	Resistance 100m Ω	1...625 Ω	10...6250	100 m Ω
	Resistance 10m Ω	1...327 Ω	100... 32700	10 m Ω
	100 Ω Pt/ $\alpha = 0.00385$	-200...+850 $^{\circ}\text{C}$	-2000... +8500	0.1 $^{\circ}\text{C}$
	200 Ω Pt/ $\alpha = 0.00385$	-200...+850 $^{\circ}\text{C}$	-2000... +8500	0.1 $^{\circ}\text{C}$
	500 Ω Pt/ $\alpha = 0.00385$	-200...+650 $^{\circ}\text{C}$	-2000... +6500	0.1 $^{\circ}\text{C}$
	100 Ω Pt/ $\alpha = 0.003916$	-200...+640 $^{\circ}\text{C}$	-2000... +6400	0.1 $^{\circ}\text{C}$
	200 Ω Pt/ $\alpha = 0.003916$	-200...+640 $^{\circ}\text{C}$	-2000... +6400	0.1 $^{\circ}\text{C}$
	500 Ω Pt/ $\alpha = 0.003916$	-200...+640 $^{\circ}\text{C}$	-2000... +6400	0.1 $^{\circ}\text{C}$
	100 Ω Nickel	-60...250 $^{\circ}\text{C}$	-600... 2500	0.1 $^{\circ}\text{C}$
	120 Ω Nickel	-80...260 $^{\circ}\text{C}$	-800... 2600	0.1 $^{\circ}\text{C}$
	200 Ω Nickel	-60...250 $^{\circ}\text{C}$	-600... 2500	0.1 $^{\circ}\text{C}$
	500 Ω Nickel	-60...250 $^{\circ}\text{C}$	-600... 2500	0.1 $^{\circ}\text{C}$
Resolution	16 bits across 625 Ω , 0.1 $^{\circ}\text{C}$ /bit or 0.1 $^{\circ}\text{F}$ /bit (RTD Sensors) 20bit Sigma-Delta modulation converter			
Data format	16 bit Integer (2's compliment)			
Module scan time	8 ms/channel @ Notch Filter = 60 Hz			
Overall accuracy	0.2% Full scale @ 0...55 $^{\circ}\text{C}$			
Settable notch filter	10 Hz (default), 25 Hz, 50 Hz, 60 Hz, 100 Hz, 250 Hz, 500 Hz			
Open wire detection	Out of range, open wiring			
Excitation current	1 mA			
Input impedance	5 m Ω			
DeviceNet power	Supply voltage - 24V dc nom Voltage range - 11...28.8V dc Power dissipation - 1.2 W max @ 28.8V dc			
Field power	Supply voltage - 24V dc nom Voltage range - 21.6...26.4V dc ($\pm 10\%$) Power dissipation - 1.5 W max @ 26.4V dc			
Isolation	I/O to logic: photocoupler isolation Isolation voltage: Type Test 1250V ac rms for 60 s DeviceNet to logic: nonisolated Field power: nonisolated			
Indicators	4 red/green I/O status			
Wiring	Terminal block (M3.0) - screw torque: 7 lb-in max (use copper or copper-clad) aluminum conductors)			

IMPORTANT: This module does not support any expansion modules.

4 Channel Input Thermocouple Base Module (1790D-T4T0)

Simplified Schematic

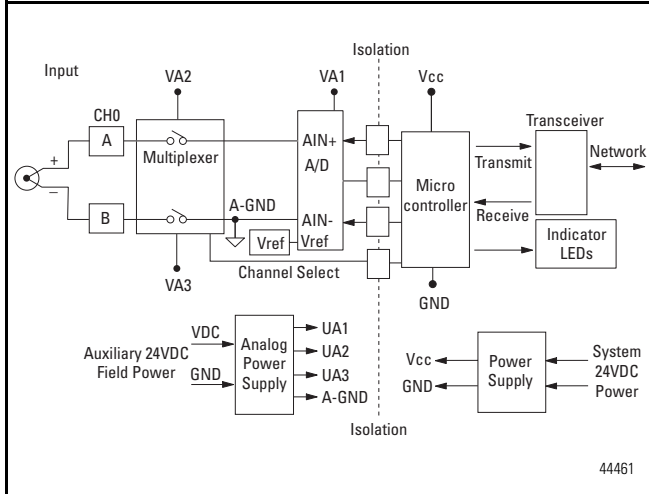

Input Data File

Word	Bit Position															
	15	14	13	12	11	10	9	8	7	6	5	4	3	2	1	0
0	Thermocouple Input Data Channel 0															
1	Thermocouple Input Data Channel 1															
2	Thermocouple Input Data Channel 2															
3	Thermocouple Input Data Channel 3															
4	Not Used			S11	S10	S9	S8	Not Used			S3	S2	S1	S0		

Wiring Diagram for Terminal Block

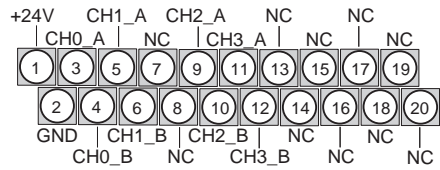

44482

- Wire pin 1 to Field Power (+) 24V dc.
Wire pin 2 to Field Power (-) GND.

Connection Sizes

Module	I/O Points	Produce (input bytes)	Consume (output bytes)
1790D-T4T0	4 channel	10	0

Word/Bit Definitions

Word	Decimal Bit	Description
Read Word 0	Bits 00...15	Channel 0 input data
Read Word 1	Bits 00...15	Channel 1 input data
Read Word 2	Bits 00...15	Channel 2 input data
Read Word 3	Bits 00...15	Channel 3 input data
Read Word 4	Bits 00...03	Underrange for individual channels - Bit 00 corresponds to input channel 0, bit 01 corresponds to input channel 1 and so on. When set (1) the input signal is below the input channel's minimum range.
	Bits 04...07	Not used: Set to 0
	Bits 08...11	Overrange for individual channels - Bit 08 corresponds to input channel 0, bit 09 corresponds to input channel 1 and so on. When set (1) the input signal is above the input channel's maximum range, or open RTD is detected.
	Bits 12...15	Not used: Set to 0

Module Specifications

1790D-T4T0			
Attribute	Value		
Inputs per module	4 channel, Thermocouple/mV Input		
Input range	±76.50mV		
Sensors supported	Sensor Type	Range	Scaling
	Voltage 10 μ V	-76.50...76.50mV	-7650...7650
	Type B	300...1800 °C	3000...18,000
	Type E	-270...1000 °C	-2700...10,000
	Type J	-210...1200 °C	-2100...12,000
	Type K	-270...1370 °C	-2700...13,700
	Type R	-50...1768 °C	-500...17,680
	Type S	-50...1768 °C	-500...17,680
	Type T	-270...400 °C	-2700...4000
	Type N	-270...1300 °C	-2700...13,000
Resolution	16 bits, 0.1 °C/bit or 0.1 °F/bit (thermocouple sensors) 20bit Sigma-Delta modulation converter		
Data format	16 bit integer (2's compliment)		
Module scan time	140 ms/channel @ Notch Filter = 60 Hz		
Overall accuracy	0.2% Full scale @ 0...55 °C		
Settable notch filter	10 Hz (default), 25 Hz, 50 Hz, 60 Hz, 100 Hz, 250 Hz, 500 Hz		
Open wire detection	Out of range, open wiring		
Cold junction compensation range	0...70 °C		
Input Impedance	5 m Ω		
General Specifications			
DeviceNet power	Supply voltage - 24V dc nom Voltage range - 11...28.8V dc Power dissipation - 1.2 W max @ 28.8V dc		
Field power	Supply voltage - 24V dc nom Voltage range - 21.6...26.4V dc (\pm 10%) Power dissipation - 1.5 W max @ 26.4V dc		
Isolation	I/O to logic: photocoupler isolation Isolation voltage: Type Test 1250V ac rms for 60 s DeviceNet to logic: nonisolated Field power: nonisolated		
Indicators	4 red/green I/O status		
Wiring	Terminal block (M3.0) - screw torque: 7 lb-in max (use copper or copper-clad aluminum conductors)		
IMPORTANT: This module does not support any expansion modules.			

2 Channel Analog Current Output Module (1790D-TN0C2)

Simplified Schematic

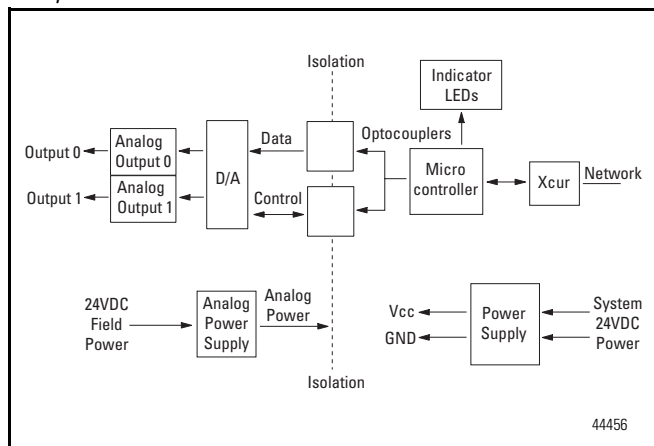

Connection Sizes

Module	I/O Points	Produce (input bytes)	Consume (output bytes)
1790D-TN0C2	2 channel	0	4

Word/Bit Definitions

Word	Decimal Bit	Description
Write Word 0	Bits 00...11	Channel 0 output data
	Bits 12...15	Not used: Set to 0
Write Word 1	Bits 00...11	Channel 1 output data
	Bits 12...15	Not used: Set to 0

Output Data File

Word	Bit Position															
	15	14	13	12	11	10	9	8	7	6	5	4	3	2	1	0
0	Not Used				Analog Output Data Channel 0											
1	Not Used				Analog Output Data Channel 1											

Wiring Diagram for Terminal Block

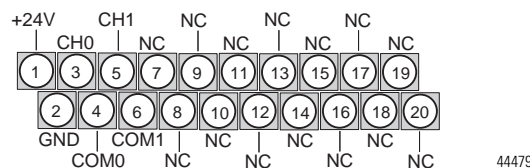

- Wire pin 1 to Field Power (+) 24V dc.
- Wire pin 2 to Field Power (-) GND.

Module Specifications

1790D-TN0C2	
Attribute	Value
Outputs per module	2 channel single-ended, nonisolated
Output current	0...20 mA
Resolution	12 bits, 1/4096 max, 4.88 μ A/bit
Converted data	Binary data 0000 to Offf (max scale)
Conversion time	2 ms/channel
Overall accuracy	0.2% Full scale @ 0...55 $^{\circ}$ C
Calibration	None required
Allowable external output load resistance	600 Ω max
Insulation resistance	20 M Ω min @ 250V dc (between insulated circuits)

General Specifications	
DeviceNet power	Supply voltage - 24V dc nom Voltage range - 11-28.8V dc Power dissipation - 1.2 W max @ 28.8V dc
Field power	Supply voltage - 24V dc nom Voltage range - 21.6...26.4V dc (\pm 10%) Power dissipation - 1.5 W max @ 26.4V dc
Isolation	I/O to logic: photocoupler isolation Isolation voltage: Type Test 1250V ac rms for 60 s DeviceNet to logic: nonisolated Field power: nonisolated
Indicators	2 red/green I/O status
Wiring	Terminal block (M3.0) - screw torque: 7 lb-in max (use copper or copper-clad aluminum conductors)

IMPORTANT: This analog base module can accommodate a **maximum** of two discrete expansion modules.

2 Channel Analog Voltage Output Module (1790D-TNOV2)

Simplified Schematic

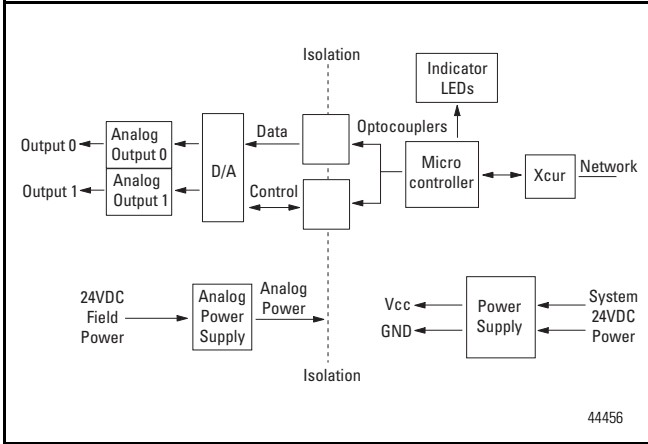

Connection Sizes

Module	I/O Points	Produce (input bytes)	Consume (output bytes)
1790D-TNOV2	2 channel	0	4

Word/Bit Definitions

Word	Decimal Bit	Description
Write Word 0	Bits 00...11	Channel 0 output data
	Bits 12...15	Not used: Set to 0
Write Word 1	Bits 00...11	Channel 1 output data
	Bits 12...15	Not used: Set to 0

Output Data File

Word	Bit Position															
	15	14	13	12	11	10	9	8	7	6	5	4	3	2	1	0
0	Not Used				Analog Output Data Channel 0											
1	Not Used				Analog Output Data Channel 1											

Wiring Diagram for Terminal Block

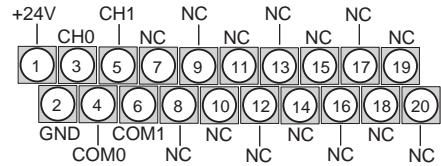

- Wire pin 1 to Field Power (+) 24V dc.
- Wire pin 2 to Field Power (-) GND.

Module Specifications

1790D-TNOV2	
Attribute	Value
Outputs per module	2 channel single-ended, nonisolated
Output voltage	0...10V
Resolution	12 bits, 1/4096 max, 2.44 mV/bit
Converted data	Binary data 0000 to 0fff (max scale)
Conversion time	2 ms/channel
Overall accuracy	0.2% Full scale @ 0...55 °C
Calibration	None required
Allowable external output load resistance	1 KΩ min
Output impedance	0.5 Ω max
Insulation resistance	20 mΩ min @ 250V dc (between insulated circuits)

General Specifications	
DeviceNet power	Supply voltage - 24V dc nom Voltage range - 11...28.8V dc Power dissipation - 1.2 W max @ 28.8V dc
Field power	Supply voltage - 24V dc nom Voltage range - 21.6...26.4V dc (±10%) Power dissipation - 1.5 W max @ 26.4V dc
Isolation	I/O to logic: photocoupler isolation Isolation voltage: Type Test 1250V ac rms for 60 s DeviceNet to logic: nonisolated Field power: nonisolated
Indicators	2 red/green I/O status
Wiring	Terminal block (M3.0) - screw torque: 7 lb-in max (use copper or copper-clad aluminum conductors)

IMPORTANT: This analog base module can accommodate a **maximum** of two discrete expansion modules.

4 Channel Analog Current Input Module (1790D-TN4C0)

Simplified Schematic

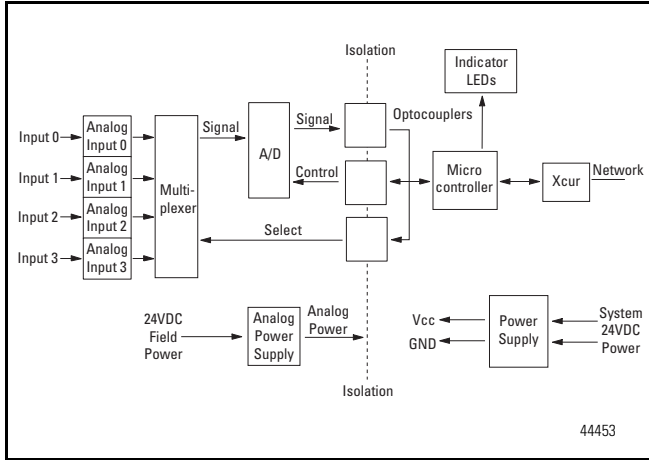

Wiring Diagram for Terminal Block

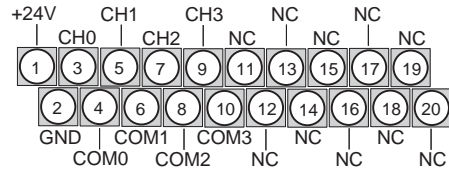

- Wire pin 1 to Field Power (+) 24V dc.
Wire pin 2 to Field Power (-) GND.

Input Data File

Word	Bit Position															
	15	14	13	12	11	10	9	8	7	6	5	4	3	2	1	0
0	Not Used				Analog Input Data Channel 0											
1	Not Used				Analog Input Data Channel 1											
2	Not Used				Analog Input Data Channel 2											
3	Not Used				Analog Input Data Channel 3											
4	Not Used												S3	S2	S1	S0

Connection Sizes

Module	I/O Points	Produce (input bytes)	Consume (output bytes)
1790D-TN4C0	4 channel	10	0

Word/Bit Definitions

Word	Decimal Bit	Description
Read Word 0	Bits 00...11	Channel 0 input data
	Bits 12...15	Not used: Set to 0
Read Word 1	Bits 00...11	Channel 1 input data
	Bits 12...15	Not used: Set to 0
Read Word 2	Bits 00...11	Channel 2 input data
	Bits 12...15	Not used: Set to 0
Read Word 3	Bits 00...11	Channel 3 input data
	Bits 12...15	Not used: Set to 0
Read Word 4	Bits 00...03	Status bits for individual channels - Bit 00 corresponds to input channel 0, bit 01 corresponds to input channel 1 and so on. When set (1) indicates: No field power Open wire (4...20 mA current input only) Under range (4...20 mA current input only) Recoverable module fault (whole channel to be set) Unrecoverable module fault (whole channel to be set)
	Bits 04...15	Not used: Set to 0

Module Specifications

1790D-TN4C0	
Attribute	Value
Inputs per module	4 channel single-ended, nonisolated
Input current (software configurable)	4...20 mA (default) 0...20 mA
Resolution	12 bits-unipolar, 1/4096 max 3.90 μ A/bit (4...20 mA) 4.88 μ A/bit (0...20 mA)
Converted data	Binary data 0000 to 0fff (max scale)
Conversion time	10 ms/channel
Overall accuracy	0.2% Full scale @ 0...55 °C
Calibration	None required
Input impedance	249 Ω
Insulation resistance	20 M Ω min @ 250V dc (between insulated circuits)
General Specifications	
DeviceNet power	Supply voltage - 24V dc nom Voltage range - 11...28.8V dc Power dissipation - 1.2 W max @ 28.8V dc
Field power	Supply Voltage - 24V dc nom Voltage Range - 21.6...26.4V dc (\pm 10%) Power Dissipation - 1.5 W max @ 26.4V dc
Isolation	I/O to logic: photocoupler isolation Isolation voltage: Type Test 1250V ac rms for 60 s DeviceNet to logic: nonisolated Field power: nonisolated
Indicators	4 red/green I/O status
Wiring	Terminal block (M3.0) - screw torque: 7 lb-in max (use copper or copper-clad aluminum conductors)
IMPORTANT: This analog base module can accommodate a maximum of two discrete expansion modules.	

4 Channel Analog Voltage Input Module (1790D-TN4V0)

Simplified Schematic

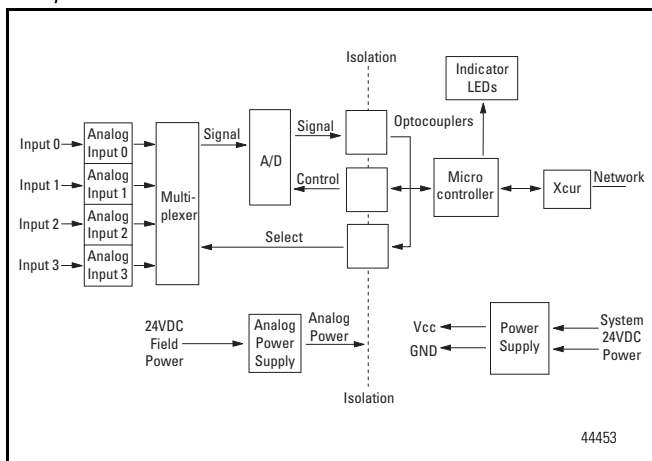

Connection Sizes

Module	I/O Points	Produce (input bytes)	Consume (output bytes)
1790D-TN4V0	4 channel	10	0

Word/Bit Definitions

Word	Decimal Bit	Description
Read Word 0	Bits 00...11	Channel 0 input data
	Bits 12...15	Not used: Set to 0
Read Word 1	Bits 00...11	Channel 1 input data
	Bits 12...15	Not used: Set to 0
Read Word 2	Bits 00...11	Channel 2 input data
	Bits 12...15	Not used: Set to 0
Read Word 3	Bits 00...11	Channel 3 input data
	Bits 12...15	Not used: Set to 0
Read Word 4	Bits 00...03	Status bits for individual channels - Bit 00 corresponds to input channel 0, bit 01 corresponds to input channel 1.... When set (1) indicates: No field power Open wire (4...20 mA current input only) Under range (4...20 mA current input only) Recoverable module fault (whole channel to be set) Unrecoverable module fault (whole channel to be set)
	Bits 04...15	Not used: Set to 0

Wiring Diagram for Terminal Block

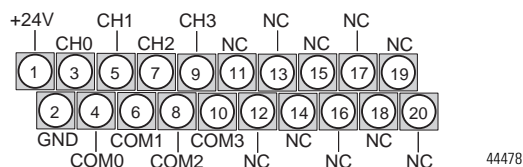

- Wire pin 1 to Field Power (+) 24V dc.
Wire pin 2 to Field Power (-) GND.

Input Data File

Word	Bit Position															
	15	14	13	12	11	10	9	8	7	6	5	4	3	2	1	0
0	Not Used				Analog Input Data Channel 0											
1	Not Used				Analog Input Data Channel 1											
2	Not Used				Analog Input Data Channel 2											
3	Not Used				Analog Input Data Channel 3											
4	Not Used												S3	S2	S1	S0

Module Specifications

1790D-TN4V0	
Attribute	Value
Inputs per module	4 channel single-ended, nonisolated
Input voltage	0...10V
Resolution	12 bits-unipolar, 1/4096 max, 2.44 mV/bit
Converted data	Binary data 0000 to 0fff (max scale)
Conversion time	10 ms/channel
Overall accuracy	0.2% Full scale @ 0...55 °C
Calibration	None required
Input impedance	500 KΩ min
Insulation resistance	20 mΩ min @ 250V dc (between insulated circuits)
General Specifications	
DeviceNet power	Supply voltage - 24V dc nom Voltage range - 11...28.8V dc Power dissipation - 1.2 W max @ 28.8V dc
Field power	Supply voltage - 24V dc nom Voltage range - 21.6...26.4V dc (±10%) Power dissipation - 1.5 W max @ 26.4V dc
Isolation	I/O to logic: photocoupler isolation Isolation voltage: Type Test 1250V ac rms for 60 s DeviceNet to logic: nonisolated Field power: nonisolated
Indicators	4 red/green I/O status
Wiring	Terminal block (M3.0) - screw torque: 7 lb-in max (use copper or copper-clad aluminum conductors)

IMPORTANT: This analog base module can accommodate a **maximum** of two discrete expansion modules.

Notes:

Allen-Bradley, ArmorBlock, ArmorBlock MaXum, ArmorPoint, ControlLogix, CompactBlock I/O, CompactLogix, Dataliner, DeviceLink, DeviceLogix, DeviceView, DTAM Micro, DTAM Plus, Ezlink, FlexArmor, FLEX I/O, MicroLogix, On-Machine, PLC-5, PanelView, POINT I/O, PowerFlex, RediPANEL, RediSTATION, Rockwell Automation, RSNetWorx, RSNetWorx for DeviceNet, Series 9000, SoftLogix, SLC, SMC, SMC Dialog Plus, 1336 FORCE, and 1336 PLUS are trademarks of Rockwell Automation, Inc.

Trademarks not belonging to Rockwell Automation are property of their respective companies.

www.rockwellautomation.com

Power, Control and Information Solutions Headquarters

Americas: Rockwell Automation, 1201 South Second Street, Milwaukee, WI 53204-2496 USA, Tel: (1) 414.382.2000, Fax: (1) 414.382.4444

Europe/Middle East/Africa: Rockwell Automation, Vorstlaan/Boulevard du Souverain 36, 1170 Brussels, Belgium, Tel: (32) 2 663 0600, Fax: (32) 2 663 0640

Asia Pacific: Rockwell Automation, Level 14, Core F, Cyberport 3, 100 Cyberport Road, Hong Kong, Tel: (852) 2887 4788, Fax: (852) 2508 1846

Publication 1790D-TD001D-EN-P - June 2008

Supersedes Publication 1790D-TD001C-EN-P - July 2006

Copyright © 2008 Rockwell Automation, Inc. All rights reserved. Printed in the U.S.A.