



Model Number

NBN40-U1LK-N0

Features

- Sensor head bidirectional and rotatable
- 40 mm non-flush

Accessories

MHW 01

Modular mounting bracket

MH 04-2057B

Mounting aid for VariKont and +U1+

Technical Data

General specifications

Switching function		Normally closed (NC)
Output type		NAMUR
Rated operating distance	s_n	40 mm
Installation		non-flush
Assured operating distance	s_a	0 ... 32.4 mm
Reduction factor r_{Al}		0.41
Reduction factor r_{Cu}		0.38
Reduction factor r_{304}		0.75
Reduction factor r_{Brass}		0.46
Output type		2-wire

Nominal ratings

Installation conditions		
A		25 mm
Nominal voltage	U_o	8.2 V
Switching frequency	f	0 ... 100 Hz
Hysteresis	H	2 ... 20 typ. 10 %
Reverse polarity protection		reverse polarity protected
Short-circuit protection		yes
Current consumption		
Measuring plate not detected		≥ 2.5 mA
Measuring plate detected		≤ 1 mA
Switching state indicator		LED, yellow

Ambient conditions

Ambient temperature		-25 ... 100 °C (-13 ... 212 °F)
Storage temperature		-40 ... 100 °C (-40 ... 212 °F)

Mechanical specifications

Connection type		screw terminals
Information for connection		A maximum of two conductors with the same core cross section may be mounted on one terminal connection! tightening torque 1.2 Nm + 10 %
Core cross-section		up to 2.5 mm ²
Minimum core cross-section		without wire end ferrule 0.5 mm ² , with connector sleeves 0.34 mm ²
Maximum core cross-section		without wire end ferrule 2.5 mm ² , with connector sleeves 1.5 mm ²
Housing material		PA
Sensing face		PA
Housing base		plastic
Degree of protection		IP67 / IP69K

General information

Use in the hazardous area		see instruction manuals
---------------------------	--	-------------------------

Compliance with standards and directives

Standard conformity	
NAMUR	EN 60947-5-6:2000 IEC 60947-5-6:1999
Electromagnetic compatibility	NE 21:2012
Standards	EN 60947-5-2:2007 EN 60947-5-2/A1:2012 IEC 60947-5-2:2007 IEC 60947-5-2 AMD 1:2012

Approvals and certificates

UL approval	
Ordinary Location	E87056
Hazardous Location	E501628
Control drawing	116-0451
CCC approval	CCC approval / marking not required for products rated ≤ 36 V

Dimensions

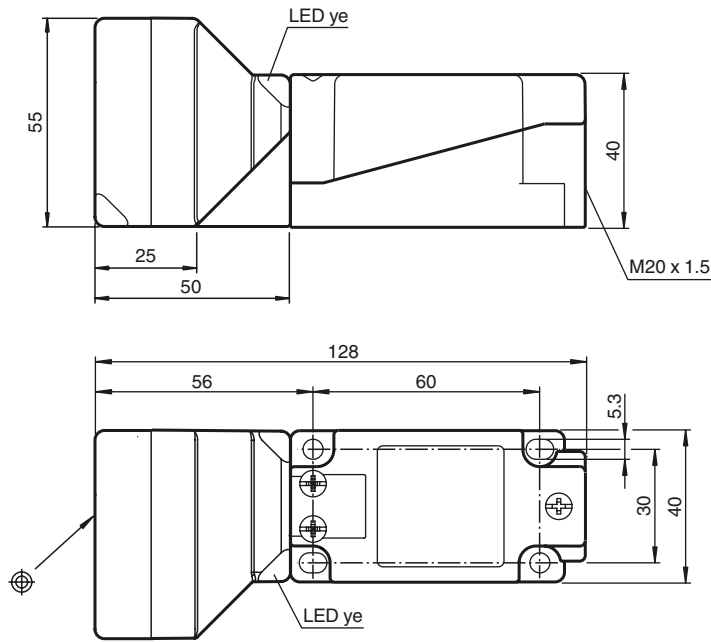

Electrical Connection

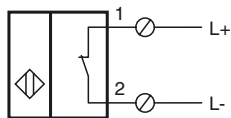

Data for application in connection with hazardous areas

Equipment protection level	Ga , Gb , Gc (ic) , Da , Mb
----------------------------	-----------------------------

Equipment protection level Ga

Type of protection	intrinsic safety
CE marking	CE 0102

Certificates

Appropriate type	NBN40-U...LK-N0...
ATEX certificate	PTB 00 ATEX 2032 X
ATEX marking	Ⓔ II 1G Ex ia IIC T6...T1 Ga
Standards	EN 60079-0:2012+A11:2013 , EN 60079-11:2012
IECEX certificate	IECEX PTB 11.0021X
IECEX marking	Ex ia IIC T6...T1 Ga
Standards	IEC 60079-0:2011 , IEC 60079-11:2011

Effective internal capacitance	C_i	≤ 165 nF A cable length of 10 m is considered.
--------------------------------	-------	--

Effective internal inductance	L_i	≤ 130 μ H A cable length of 10 m is considered.
-------------------------------	-------	---

Maximum permissible ambient temperature T_{amb}	Also observe the maximum permissible ambient temperature stated in the general technical data. Keep to the lower of the two values.
---	--

for ATEX	<p>at $U_i = 16$ V , $I_i = 25$ mA , $P_i = 34$ mW , T6 : 56 °C (132.8 °F) T5 : 68 °C (154.4 °F) T4 : 96 °C (204.8 °F) T3 : 96 °C (204.8 °F) T2 : 96 °C (204.8 °F) T1 : 96 °C (204.8 °F)</p> <p>at $U_i = 16$ V , $I_i = 25$ mA , $P_i = 64$ mW , T6 : 49 °C (120.2 °F) T5 : 61 °C (141.8 °F) T4 : 89 °C (192.2 °F) T3 : 89 °C (192.2 °F) T2 : 89 °C (192.2 °F) T1 : 89 °C (192.2 °F)</p> <p>at $U_i = 16$ V , $I_i = 52$ mA , $P_i = 169$ mW , T6 : 28 °C (82.4 °F) T5 : 40 °C (104 °F) T4 : 68 °C (154.4 °F) T3 : 68 °C (154.4 °F) T2 : 68 °C (154.4 °F) T1 : 68 °C (154.4 °F)</p> <p>at $U_i = 16$ V , $I_i = 76$ mA , $P_i = 242$ mW , T6 : 13 °C (55.4 °F) T5 : 25 °C (77 °F) T4 : 53 °C (127.4 °F) T3 : 53 °C (127.4 °F) T2 : 53 °C (127.4 °F) T1 : 53 °C (127.4 °F)</p>
----------	--

for IECEX	<p>at $U_i = 16$ V , $I_i = 25$ mA , $P_i = 34$ mW , T6 : 73 °C (163.4 °F) T5 : 88 °C (190.4 °F) T4 : 100 °C (212 °F) T3 : 100 °C (212 °F) T2 : 100 °C (212 °F) T1 : 100 °C (212 °F)</p> <p>at $U_i = 16$ V , $I_i = 25$ mA , $P_i = 64$ mW , T6 : 66 °C (150.8 °F) T5 : 81 °C (177.8 °F) T4 : 100 °C (212 °F) T3 : 100 °C (212 °F) T2 : 100 °C (212 °F) T1 : 100 °C (212 °F)</p> <p>at $U_i = 16$ V , $I_i = 52$ mA , $P_i = 169$ mW , T6 : 45 °C (113 °F) T5 : 60 °C (140 °F) T4 : 89 °C (192.2 °F) T3 : 89 °C (192.2 °F) T2 : 89 °C (192.2 °F) T1 : 89 °C (192.2 °F)</p> <p>at $U_i = 16$ V , $I_i = 76$ mA , $P_i = 242$ mW , T6 : 30 °C (86 °F) T5 : 45 °C (113 °F) T4 : 74 °C (165.2 °F) T3 : 74 °C (165.2 °F) T2 : 74 °C (165.2 °F) T1 : 74 °C (165.2 °F)</p>
-----------	--

Equipment protection level Gb

Type of protection	intrinsic safety	
CE marking	CE 0102	
Certificates		
Appropriate type	NBN40-U...LK-N0...	
ATEX certificate	PTB 00 ATEX 2032 X	
ATEX marking	II 1G Ex ia IIC T6...T1 Ga	
Standards	EN 60079-0:2012+A11:2013 , EN 60079-11:2012	
IECEX certificate	IECEX PTB 11.0021X	
IECEX marking	Ex ia IIC T6...T1 Ga	
Standards	IEC 60079-0:2011 , IEC 60079-11:2011	
Effective internal capacitance	C_i	≤ 165 nF A cable length of 10 m is considered.
Effective internal inductance	L_i	≤ 130 μ H A cable length of 10 m is considered.
Maximum permissible ambient temperature T_{amb}	Also observe the maximum permissible ambient temperature stated in the general technical data. Keep to the lower of the two values. at $U_i = 16$ V , $I_i = 25$ mA , $P_i = 34$ mW , T6 : 73 °C (163.4 °F) T5 : 88 °C (190.4 °F) T4 : 100 °C (212 °F) T3 : 100 °C (212 °F) T2 : 100 °C (212 °F) T1 : 100 °C (212 °F) at $U_i = 16$ V , $I_i = 25$ mA , $P_i = 64$ mW , T6 : 66 °C (150.8 °F) T5 : 81 °C (177.8 °F) T4 : 100 °C (212 °F) T3 : 100 °C (212 °F) T2 : 100 °C (212 °F) T1 : 100 °C (212 °F) at $U_i = 16$ V , $I_i = 52$ mA , $P_i = 169$ mW , T6 : 45 °C (113 °F) T5 : 60 °C (140 °F) T4 : 89 °C (192.2 °F) T3 : 89 °C (192.2 °F) T2 : 89 °C (192.2 °F) T1 : 89 °C (192.2 °F) at $U_i = 16$ V , $I_i = 76$ mA , $P_i = 242$ mW , T6 : 30 °C (86 °F) T5 : 45 °C (113 °F) T4 : 74 °C (165.2 °F) T3 : 74 °C (165.2 °F) T2 : 74 °C (165.2 °F) T1 : 74 °C (165.2 °F)	

Equipment protection level Gc (ic)

Type of protection	intrinsic safety	
CE marking	CE	
Certificates		
ATEX certificate	PF13CERT2895 X	
ATEX marking	II 3G Ex ic IIC T6...T1 Gc	
Standards	EN 60079-0:2012+A11:2013 , EN 60079-11:2012	
Effective internal capacitance	C_i	≤ 165 nF A cable length of 10 m is considered.
Effective internal inductance	L_i	≤ 130 μ H A cable length of 10 m is considered.
Maximum permissible ambient temperature T_{amb}	Also observe the maximum permissible ambient temperature stated in the general technical data. Keep to the lower of the two values. at $U_i = 20$ V , $I_i = 25$ mA , $P_i = 34$ mW , T6 : 66 °C (150.8 °F) T5 : 81 °C (177.8 °F) T4 : 100 °C (212 °F) T3 : 100 °C (212 °F) T2 : 100 °C (212 °F) T1 : 100 °C (212 °F) at $U_i = 20$ V , $I_i = 25$ mA , $P_i = 64$ mW , T6 : 66 °C (150.8 °F) T5 : 81 °C (177.8 °F) T4 : 100 °C (212 °F) T3 : 100 °C (212 °F) T2 : 100 °C (212 °F) T1 : 100 °C (212 °F) at $U_i = 20$ V , $I_i = 52$ mA , $P_i = 169$ mW , T6 : 45 °C (113 °F) T5 : 60 °C (140 °F) T4 : 89 °C (192.2 °F) T3 : 89 °C (192.2 °F) T2 : 89 °C (192.2 °F) T1 : 89 °C (192.2 °F) at $U_i = 20$ V , $I_i = 76$ mA , $P_i = 242$ mW , T6 : 30 °C (86 °F) T5 : 45 °C (113 °F) T4 : 74 °C (165.2 °F) T3 : 74 °C (165.2 °F) T2 : 74 °C (165.2 °F) T1 : 74 °C (165.2 °F)	

Release date: 2019-05-22 11:06 Date of issue: 2019-05-22 217923_eng.xml

Equipment protection level Da

Type of protection	intrinsic safety	
CE marking	CE 0102	
Certificates		
Appropriate type	NBN40-U...LK-N0...	
ATEX certificate	PTB 00 ATEX 2032 X	
ATEX marking	Ⓔ II 1D Ex ia IIIC T135°C Da	
Standards	EN 60079-0:2012+A11:2013 , EN 60079-11:2012	
IECEX certificate	IECEX PTB 11.0021X	
IECEX marking	Ex ia IIIC T135°C Da	
Standards	IEC 60079-0:2011 , IEC 60079-11:2011	
Effective internal capacitance	C_i	≤ 165 nF A cable length of 10 m is considered.
Effective internal inductance	L_i	≤ 130 μH A cable length of 10 m is considered.
Maximum permissible ambient temperature T_{amb}	Also observe the maximum permissible ambient temperature stated in the general technical data. Keep to the lower of the two values. at $U_i = 16\text{ V}$, $I_i = 25\text{ mA}$, $P_i = 34\text{ mW}$: 100 °C (212 °F) at $U_i = 16\text{ V}$, $I_i = 25\text{ mA}$, $P_i = 64\text{ mW}$: 100 °C (212 °F) at $U_i = 16\text{ V}$, $I_i = 52\text{ mA}$, $P_i = 169\text{ mW}$: 89 °C (192.2 °F) at $U_i = 16\text{ V}$, $I_i = 76\text{ mA}$, $P_i = 242\text{ mW}$: 74 °C (165.2 °F)	

Equipment protection level Mb

Type of protection	intrinsic safety	
Certificates		
Appropriate type	NBN40-U...LK-N0...	
IECEX certificate	IECEX PTB 11.0021X	
IECEX marking	Ex ia I Mb	
Standards	IEC 60079-0:2011 , IEC 60079-11:2011	
Effective internal capacitance	C_i	≤ 165 nF A cable length of 10 m is considered.
Effective internal inductance	L_i	≤ 130 μH A cable length of 10 m is considered.
Maximum permissible ambient temperature T_{amb}	Also observe the maximum permissible ambient temperature stated in the general technical data. Keep to the lower of the two values. at $U_i = 16\text{ V}$, $I_i = 25\text{ mA}$, $P_i = 34\text{ mW}$: 100 °C (212 °F) at $U_i = 16\text{ V}$, $I_i = 25\text{ mA}$, $P_i = 64\text{ mW}$: 100 °C (212 °F) at $U_i = 16\text{ V}$, $I_i = 52\text{ mA}$, $P_i = 169\text{ mW}$: 89 °C (192.2 °F) at $U_i = 16\text{ V}$, $I_i = 76\text{ mA}$, $P_i = 242\text{ mW}$: 74 °C (165.2 °F)	