

Slim and Compact Switch with Better Seal and Ensuring Longer Service Life than D4E



- Flat springs with an improved lever ratio of the built-in switch ensure smooth snap action and long life expectancy.
- Protection cover protects the built-in switch from dust and oil. Plunger incorporates a tough seal cap that lasts for a long time.
- One touch connector eliminates need for tedious wiring operations and reduces downtime for wiring and maintenance (models with standard, easy-to-use screw terminals are also available).
- Minute load model with gold cladding is optimal for electronic control.
- Molded terminal types as well as molded terminal types with operating indicator lamps are available for screw terminal systems.
- Approved by EN, UL, CSA, and CCC (Chinese standard).
(Ask your OMRON representative for Information on approved models.)
- No difference in mounting pitch and characteristics between D4E-□N and D4E models.



Be sure to read *Safety Precautions* on page 9 to 10 and *Safety Precautions for All Limit Switches*.

Model Number Structure

Model Number Legend (Not all combinations are possible. Ask your OMRON representative for details.)

D4E-□□□□N

(1)(2) (3) (4)

(1) Rated Current

- 1: 5 A at 125 VAC
(1 A at 125 VAC/30 VDC for model with a connector)
- 2: 0.1 A at 125 VAC
(0.1 A at 125 VAC/30 VDC for model with a connector)

(2) Actuator

- A: Roller plunger
- B: Crossroller plunger
- C: Plunger
- D: Sealed roller plunger
- E: Sealed crossroller plunger
- F: Sealed plunger
- G: Roller lever
- H: One-way action roller lever

(3) Terminals

- 00: AC connector
 - 10: DC connector
 - 20: Screw terminals without a cable
 - 21: Screw terminals with a cable (right-hand)
 - 22: Screw terminals with a cable (left-hand)
 - 23: Molded terminals with a cable (right-hand)
 - 24: Molded terminals with a cable (left-hand)
(Cable is S-FLEX VCTF 3 m)
- Note: The terminal specifications in model numbers are not the same for D4E-N and D4E Switches.









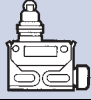
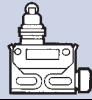
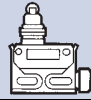
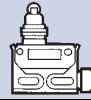

(4) Operation Indicator

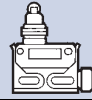
- None: Without operation indicator
 - L: Neon lamp (250 VAC)
 - L2: LED (24 VDC)
- Note: Only the molded terminal models can be equipped with an operation indicators.

Comparison of New and Old Molded Terminal Models

Model	D4E-N	D4E
Right-hand	D4E-□□23N	D4E-□□21
Left-hand	D4E-□□24N	D4E-□□23

Ordering Information

Type	One-touch connector type		Screw terminal type			
	General-purpose	Micro load	General-purpose without cable	Micro load without cable	General-purpose with cable	Micro load with cable
						
Actuator	Model	Model	Model	Model	Model	Model
Roller plunger 	D4E-1A□□0N	D4E-2A10N	D4E-1A20N	D4E-2A20N	D4E-1A21N	D4E-2A21N
Crossroller plunger 	D4E-1B□□0N	D4E-2B10N	D4E-1B20N	D4E-2B20N	D4E-1B21N	D4E-2B21N
Plunger 	D4E-1C□□0N	D4E-2C□□0N	D4E-1C20N	D4E-2C20N	D4E-1C21N	D4E-2C21N
Sealed roller plunger 	D4E-1D□□0N	D4E-2D10N	D4E-1D20N	D4E-2D20N	D4E-1D21N	D4E-2D21N
Sealed crossroller plunger 	D4E-1E□□0N	---	D4E-1E20N	D4E-2E20N	D4E-1E21N	D4E-2E21N
Sealed plunger 	D4E-1F□□0N	D4E-2F10N	D4E-1F20N	D4E-2F20N	D4E-1F21N	D4E-2F21N
Roller lever 	D4E-1G□□0N	D4E-2G10N	D4E-1G20N	D4E-2G20N	D4E-1G21N	D4E-2G21N
One-way action roller lever 	D4E-1H00N	---	D4E-1H20N	D4E-2H20N	D4E-1H21N	---

Note: 1. When ordering, specify the current type by replacing the blank box of the model number with 0 for AC connector or 1 for DC connector.
 2. For the plunger and lever actuator models, the NC and NO terminal indicators are reversed.
 3. Models are also available with molded terminals and with molded terminals and operation indicators. Refer to page 8.

Plug

Select one of the specified Connector Plugs from the following table.

Applicable limit switches	Current Type	Type	No. of conductors	Cable length	Plug
D4E-□□00N	AC		4	2 m	XS2F-A421-D90-A
				5 m	XS2F-A421-G90-A
D4E-□□10N	DC			2 m	XS2F-D421-D80-A
				5 m	XS2F-D421-G80-A

Specifications

Approved Standards

Agency	Standard	File No.	Approved models
UL	UL508	E76675	D4E-□□20N Switches only except for Indicator-equipped Switches
CSA	CSA C22.2 No. 14	LR45746	D4E-□□20N Switches only except for Indicator-equipped Switches
TÜV Rheinland	EN60947-5-1	R9551015	Ask your OMRON representative for information on approved models.
CCC (CQC)	GB14048.5	2003010305086795	Ask your OMRON representative for information on approved models.

Ratings

Rated voltage	Standard load								Micro load	
	Non-inductive load (A)				Inductive load (A)				Non-inductive load (A)	
	Resistive load		Lamp load		Inductive load		Motor load		Resistive load	
	NC	NO	NC	NO	NC	NO	NC	NO	NC	NO
125 VAC	5 (1)		1.5 (1)		3 (1)		2 (1)	1 (1)	0.1	
250 VAC	5 (1)		1.5 (1)		3 (1)		1	0.5	---	
8 VDC	5 (1)		---		1.5 (1)		---	---	0.1	
14 VDC	5 (1)		---		1.5 (1)		---	---	0.1	
30 VDC	5 (1)		---		1.5 (1)		---	---	0.1	
125 VDC	0.5		---		0.05		---	---	---	
250 VDC	0.25		---		0.03		---	---	---	

Inrush current	NC	10 A max.
	NO	10 A max.

Note: 1. The above current ratings are for a standard current and the values in parentheses are for models with a connector.
 2. Inductive loads have a power factor of 0.4 min. (AC) and a time constant of 7 ms max. (DC).
 3. Lamp load has an inrush current of 10 times the steady-state current.
 4. Motor load has an inrush current of 6 times the steady-state current.

Approved Standard Ratings
UL/CSA
A300

Voltage	Carry current	Current (A)		Volt-amperes (VA)	
		Make	Break	Make	Break
120 V 240 V	10 A	60 A 30 A	6 A 3 A	7,200	720

Note: 1. □: Actuator variation of item II
 2. AC-14 0.5 A/125 VAC means as follows:
 3. Applicable category: AC-14
 Rated operating current (I_o): 0.5 A
 Rated operating voltage (U_o): 125 VAC

TÜV (EN60947-5-1), CCC (GB14048.5)

D4E-1 G 23 L N
I II III IV

I	II	Model		Applicable category and ratings	Thermal current (I _{th})	Indicator
		III	IV			
1	□	00		AC-14 0.5 A/125 VAC	5 A	---
1	□	10		DC-12 0.5 A/30 VDC	5 A	---
1	□	20, 21, 22		AC-15 2A/250 VAC	5 A	---
				DC-12 2A/48 VDC		
1	□	23, 24	L	AC-15 2A/250 VAC	5 A	Neon lamp
1	□	23, 24	L1	DC-12 2A/12 VDC	5 A	LED
1	□	23, 24	L2	DC-12 2A/24 VDC	5 A	LED
1	□	23, 24	L3	DC-12 2A/48 VDC	5 A	LED
2	□	00		AC-14 0.1A/125 VAC	0.5 A	---
2	□	10		DC-12 0.1A/30 VDC	0.5 A	---
2	□	20, 21, 22		AC-14 0.1A/125 VAC	0.5 A	---
				DC-12 0.1A/48 VDC		
2	□	23, 24	L	AC-14 0.1A/125 VAC	0.5 A	Neon lamp
2	□	23, 24	L1	DC-12 0.1A/12 VDC	0.5 A	LED
2	□	23, 24	L2	DC-12 0.1A/24 VDC	0.5 A	LED
2	□	23, 24	L3	DC-12 0.1A/48 VDC	0.5 A	LED

Characteristics

Degree of protection		IP67
Durability *	Mechanical	10,000,000 operations min.
	Electrical	500,000 operations min. (5 A at 250 VAC, resistive load) 5,000,000 operations min. (10 mA at 24 VDC, resistive load)
Operating speed		0.1 mm/sec to 0.5 m/sec
Operating frequency		Mechanical: 120 operations/min Electrical: 30 operations/min
Rated frequency		50/60 Hz
Insulation resistance		100 MΩ min. (at 500 VDC)
Contact resistance		15 mΩ max. (initial value for the built-in switch when tested alone)
Dielectric strength	Between terminals of same polarity	1,000 VAC, 50/60 Hz for 1 min
	Between each terminal and non-current-carrying metal part	1,500 VAC, 50/60 Hz for 1 min/Uimp at 2.5 kV (EN60947-5-1)
Rated insulation voltage (Ui)		250V
Pollution degree (operating environment)		3 (EN60947-5-1)
Short-circuit protective device (SCPD)		10 A fuse (type gG or gI, IEC60269 approved)
Conditional short-circuit current		100 A (EN60947-5-1)
Conventional enclosed thermal current (I _{th})		5 A (EN60947-5-1)
Protection against electric shock		Class II (grounding not required with double insulation)
Vibration resistance	Malfunction	10 to 55 Hz, 1.5-mm double amplitude
	Destruction	1,000 m/s ² min.
Shock resistance	Destruction	300 m/s ² min.
	Malfunction	300 m/s ² min.
Ambient operating temperature		-10°C to +80°C (with no icing)
Ambient operating humidity		35% to 95%RH
Weight		Approx. 86 g (in case of roller plunger)

Engineering Data

General-purpose Models

Electrical Durability (cosφ=1)

Operating temperature: +5°C to +30°C

Operating humidity: 40% to 70%RH.

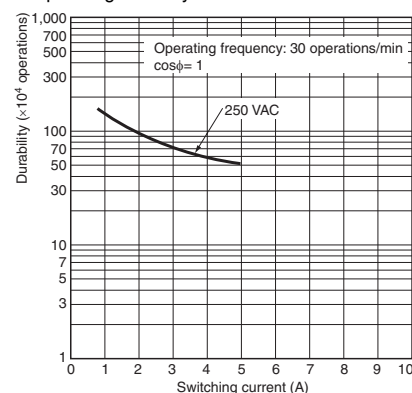

Note: 1. The above values are initial values.
 2. The above ratings may vary depending on the model. Contact your OMRON representative for further details.

* Durability values are calculated at an operating temperature of +5°C to +35°C, and an operating humidity of 40% to 70%RH.

Structure and Nomenclature

Structure

- Movable Plunger**
- Rubber Cap (NBR)**
 - Rubber cap provides a tight seal and ensures a long service life and smooth reset at low temperatures.
- Seal Packing (NBR)**
 - Seal packing withstands a pressure of 186 kPa.
- Terminal Protection Cover**
 - D4E-□N has a wide wiring space of 10 mm horizontally.
- Screw Terminal**
 - Screw terminal incorporates a M3 screw with a toothed washer.
- Bearing**
 - The bearing load strength has been increased to prevent faulty resetting of the bearing, which may occur when the roller is pressed with excessive force.
- Built-in Switch**
 - Switch cover ensures high insulation between the terminals and die-cast. Double insulation means that grounding is unnecessary. Meets UL, CSA, and EN standards.
 - Prevents the movable piece from being pushed in too far, and thereby contributes to a longer service life.
- Die-cast Case**
 - Zinc die-cast case is anti-corrosive and tough.
- Wiring Ease**
 - Wired made easier using (D4CC-type) plug-in connector.

Contact Form
Screw Terminal Type
Plunger

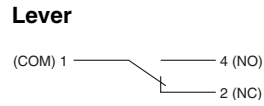
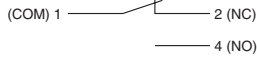

Connector Type

For AC

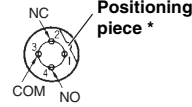

For DC

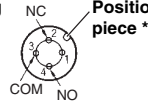

* The position of the positioning piece is not always the same. If using an L-shaped connector causes problems in application, use a straight connector.

Dimensions and Operating Characteristics

(Unit: mm)

Roller Plunger

- D4E-1A00N
- D4E-2A00N
- D4E-1A10N
- D4E-2A10N

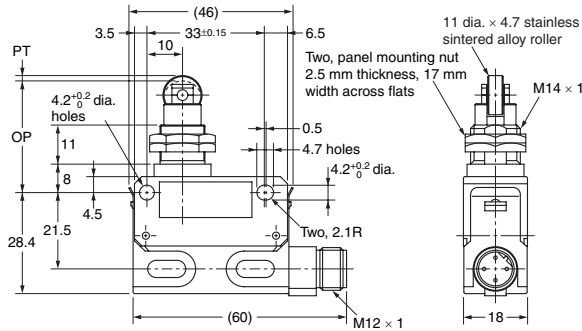
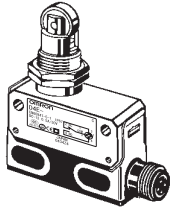

Operating force	OF	max.	11.77 N
Release force	RF	min.	4.90 N
Pretravel	PT	max.	1.5 mm
Overtravel	OT	min.	3 mm
Movement Differential	MD		(0.1 mm)
Operating Position	OP		31.4±0.8 mm

() :Reference Value

Roller Plunger

- D4E-1A20N *1
- D4E-2A20N *1
- D4E-1A21N *2
- D4E-2A21N *2

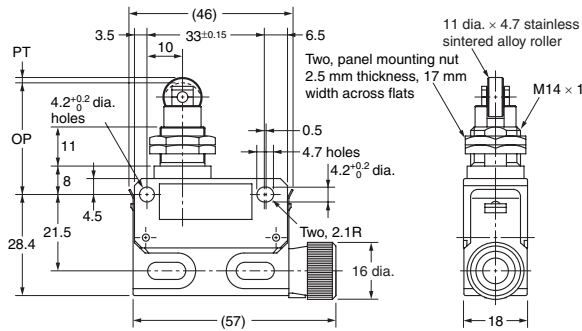
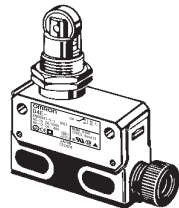

Operating force	OF	max.	11.77 N
Release force	RF	min.	4.90 N
Pretravel	PT	max.	1.5 mm
Overtravel	OT	min.	3 mm
Movement Differential	MD		(0.1 mm)
Operating Position	OP		31.4±0.8 mm

() :Reference Value

Cross Roller Plunger

- D4E-1B00N
- D4E-2B00N
- D4E-1B10N
- D4E-2B10N

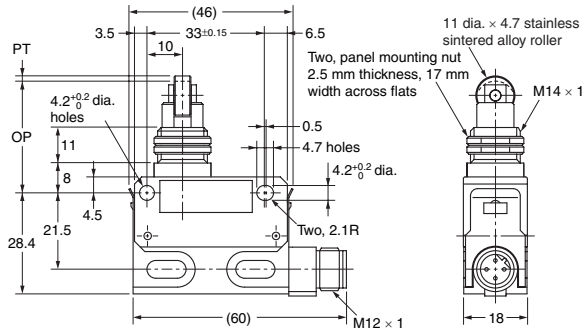
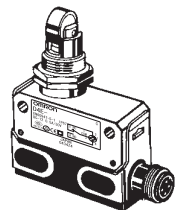

Operating force	OF	max.	11.77 N
Release force	RF	min.	4.90 N
Pretravel	PT	max.	1.5 mm
Overtravel	OT	min.	3 mm
Movement Differential	MD		(0.1 mm)
Operating Position	OP		31.4±0.8 mm

() :Reference Value

Cross Roller Plunger

- D4E-1B20N *1
- D4E-2B20N *1
- D4E-1B21N *2
- D4E-2B21N *2

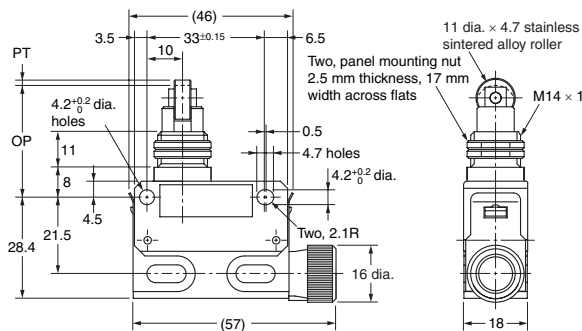
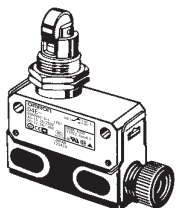

Operating force	OF	max.	11.77 N
Release force	RF	min.	4.90 N
Pretravel	PT	max.	1.5 mm
Overtravel	OT	min.	3 mm
Movement Differential	MD		(0.1 mm)
Operating Position	OP		31.4±0.8 mm

() :Reference Value

Note: Unless otherwise specified, a tolerance of ±0.4 mm applies to all dimensions.

*1. A 5.8-dia. to 7.6-dia. cable can be applied to the seal rubber for the lead wire outlet.

*2. A 3-m lead wire cable equivalent to the 3-conductor VCTF S-FLEX cable (0.75 mm², 7 mm in dia.) is provided.

Plunger

D4E-1C00N
D4E-2C00N
D4E-1C10N
D4E-2C10N

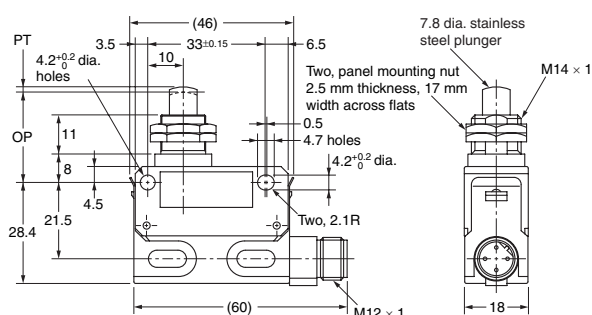
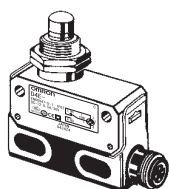

Operating force	OF	max.	11.77 N
Release force	RF	min.	4.90 N
Pretravel	PT	max.	1.5 mm
Overtravel	OT	min.	3 mm
Movement Differential	MD		(0.1 mm)
Operating Position	OP		25.4±0.8 mm

() :Reference Value

Plunger

D4E-1C20N *1
D4E-2C20N *1
D4E-1C21N *2
D4E-2C21N *2

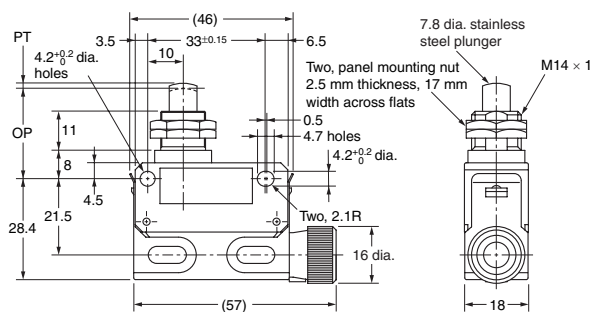
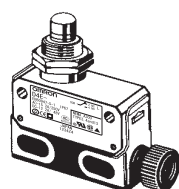

Operating force	OF	max.	11.77 N
Release force	RF	min.	4.90 N
Pretravel	PT	max.	1.5 mm
Overtravel	OT	min.	3 mm
Movement Differential	MD		(0.1 mm)
Operating Position	OP		25.4±0.8 mm

() :Reference Value

Sealed Roller Plunger

D4E-1D00N
D4E-2D00N
D4E-1D10N
D4E-2D10N

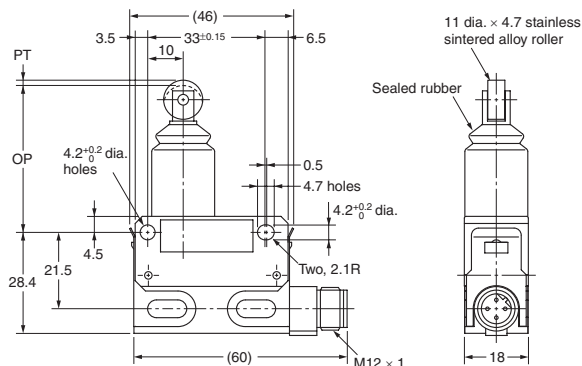
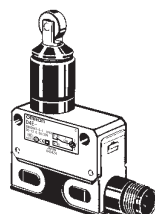

Operating force	OF	max.	11.77 N
Release force	RF	min.	4.90 N
Pretravel	PT	max.	1.5 mm
Overtravel	OT	min.	3 mm
Movement Differential	MD		(0.1 mm)
Operating Position	OP		41.3±0.8 mm

() :Reference Value

Sealed Roller Plunger

D4E-1D20N *1
D4E-2D20N *1
D4E-1D21N *2
D4E-2D21N *2

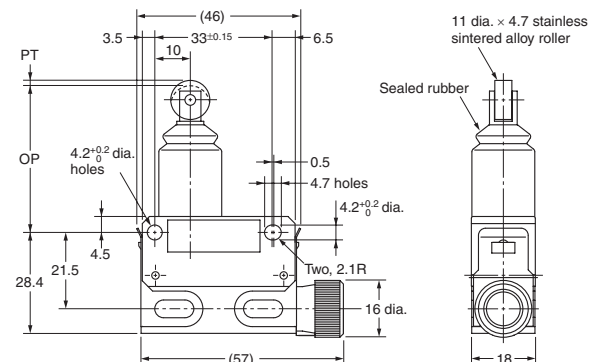
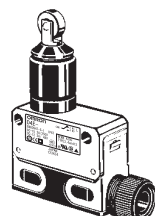

Operating force	OF	max.	11.77 N
Release force	RF	min.	4.90 N
Pretravel	PT	max.	1.5 mm
Overtravel	OT	min.	3 mm
Movement Differential	MD		(0.1 mm)
Operating Position	OP		41.3±0.8 mm

() :Reference Value

Note: Unless otherwise specified, a tolerance of ±0.4 mm applies to all dimensions.

*1. A 5.8-dia. to 7.6-dia. cable can be applied to the seal rubber for the lead wire outlet.

*2. A 3-m lead wire cable equivalent to the 3-conductor VCTF S-FLEX cable (0.75 mm², 7 mm in dia.) is provided.

Sealed Cross Roller Plunger

D4E-1E00N
D4E-1E10N

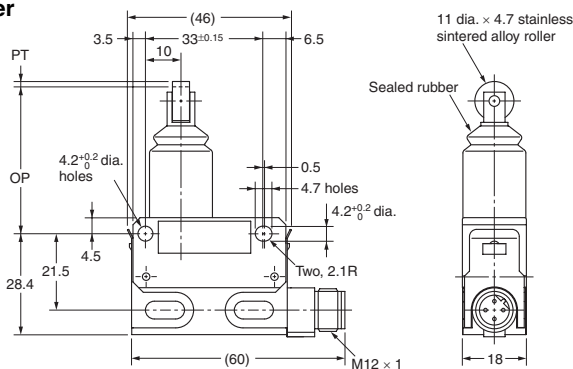
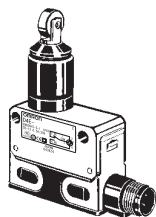

Operating force	OF	max.	11.77 N
Release force	RF	min.	4.90 N
Pretravel	PT	max.	1.5 mm
Overtravel	OT	min.	3 mm
Movement Differential	MD		(0.1 mm)
Operating Position	OP		41.3±0.8 mm

() :Reference Value

Sealed Cross Roller Plunger

D4E-1E20N *1
D4E-2E20N *1
D4E-1E21N *2
D4E-2E21N *2

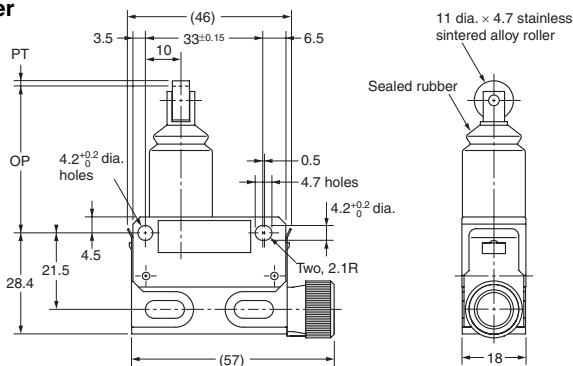
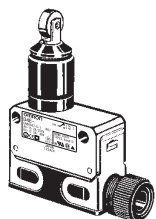

Operating force	OF	max.	11.77 N
Release force	RF	min.	4.90 N
Pretravel	PT	max.	1.5 mm
Overtravel	OT	min.	3 mm
Movement Differential	MD		(0.1 mm)
Operating Position	OP		41.3±0.8 mm

() :Reference Value

Sealed Plunger

D4E-1F00N
D4E-2F00N
D4E-1F10N
D4E-2F10N

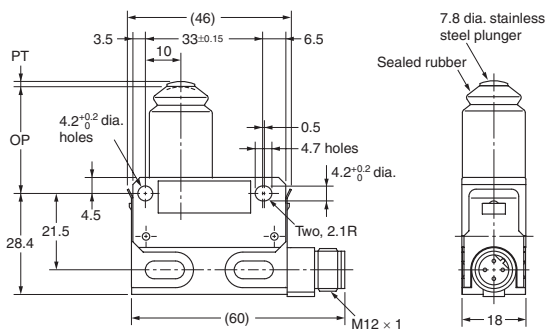
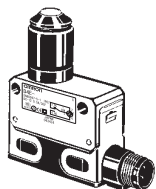

Operating force	OF	max.	11.77 N
Release force	RF	min.	4.90 N
Pretravel	PT	max.	1.5 mm
Overtravel	OT	min.	3 mm
Movement Differential	MD		(0.1 mm)
Operating Position	OP		30±0.8 mm

() :Reference Value

Sealed Plunger

D4E-1F20N *1
D4E-2F20N *1
D4E-1F21N *2
D4E-2F21N *2

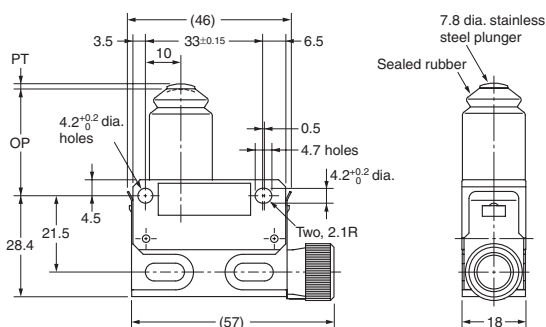
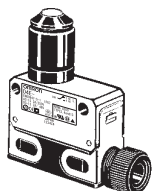

Operating force	OF	max.	11.77 N
Release force	RF	min.	4.90 N
Pretravel	PT	max.	1.5 mm
Overtravel	OT	min.	3 mm
Movement Differential	MD		(0.1 mm)
Operating Position	OP		30±0.8 mm

() :Reference Value

Note: Unless otherwise specified, a tolerance of ±0.4 mm applies to all dimensions.

*1. A 5.8-dia. to 7.6-dia. cable can be applied to the seal rubber for the lead wire outlet.

*2. A 3-m lead wire cable equivalent to the 3-conductor VCTF S-FLEX cable (0.75 mm², 7 mm in dia.) is provided.

Roller Lever
D4E-1G00N
D4E-2G00N
D4E-1G10N
D4E-2G10N

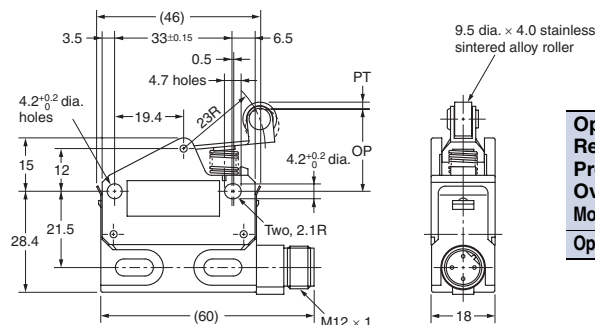
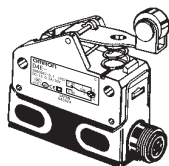

Operating force	OF	max.	3.92 N
Release force	RF	min.	0.78 N
Pretravel	PT	max.	2 mm
Overtravel	OT	min.	4 mm
Movement Differential	MD		(0.3 mm)
Operating Position	OP		23.1±0.8 mm

() :Reference Value

Roller Lever
D4E-1G20N *1
D4E-2G20N *1
D4E-1G21N *2
D4E-2G21N *2

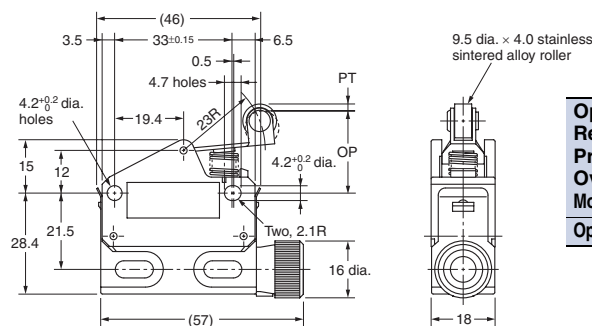
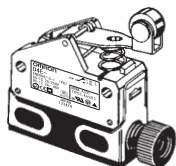

Operating force	OF	max.	3.92 N
Release force	RF	min.	0.78 N
Pretravel	PT	max.	2 mm
Overtravel	OT	min.	4 mm
Movement Differential	MD		(0.3 mm)
Operating Position	OP		23.1±0.8 mm

() :Reference Value

One-way Action Roller Lever
D4E-1H00N
D4E-2H00N
D4E-1H10N
D4E-2H10N

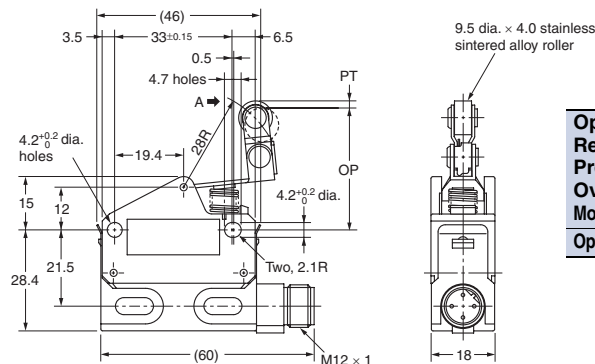
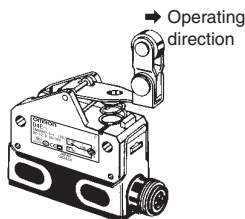

Operating force	OF	max.	3.92 N
Release force	RF	min.	0.78 N
Pretravel	PT	max.	2 mm
Overtravel	OT	min.	4 mm
Movement Differential	MD		(0.3 mm)
Operating Position	OP		34.3±0.8 mm

() :Reference Value

One-way Action Roller Lever
D4E-1H20N *1
D4E-2H20N *1
D4E-1H21N *2
D4E-2H21N *2

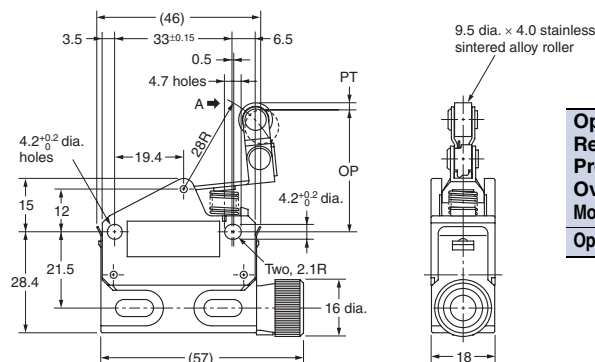
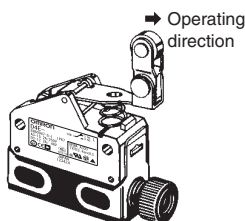

Operating force	OF	max.	3.92 N
Release force	RF	min.	0.78 N
Pretravel	PT	max.	2 mm
Overtravel	OT	min.	4 mm
Movement Differential	MD		(0.3 mm)
Operating Position	OP		34.3±0.8 mm

() :Reference Value

Note: Unless otherwise specified, a tolerance of ±0.4 mm applies to all dimensions.

*1. A 5.8-dia. to 7.6-dia. cable can be applied to the seal rubber for the lead wire outlet.

*2. A 3-m lead wire cable equivalent to the 3-conductor VCTF S-FLEX cable (0.75 mm², 7 mm in dia.) is provided.

Molded Terminal Models

The molded-terminal model is available with right-hand and left-hand leads and is recommended for use where the Switch is exposed to dust, oil or moisture. It can be used like a screw-terminal model (with a cable), and the dimensions and operating characteristics are the same as for standard models.

Suffix by Location of Lead Outlet

Location of lead outlet	Suffix for pre-wired terminal	
	COM, NC, NO	
Right-hand	D4E-□□23N	(1)
Left-hand	D4E-□□24N	(2)

Example:
 Standard type: D4E-1A20N
 Location of lead output:
 Right-hand → D4E-1A23N

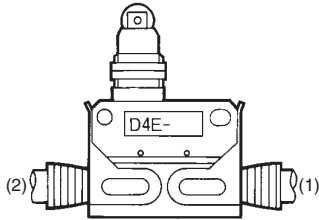

Lead Supplies

Specifications	Nominal cross-sectional area (mm ²)	External diameter	Terminal connections	Cable length (m)
Leads	0.75	3 conductors	Black: COM White: NO Red: NC	3 (Standard)
		7 mm dia.		
V.C.T.F. S-FLEX (vinyl cabtire coat)				

Operation of Indicator-equipped Models

- The molded terminal model may be equipped with an operation indicator (neon lamp or LED) upon request to facilitate maintenance and inspection.
- The operation indicator is designed to illuminate when the Switch is not operating. (Because of the molded terminal model, any change to the Switch wiring cannot be made.)

AC Operation

- The operating voltage is 90 to 250 VAC.

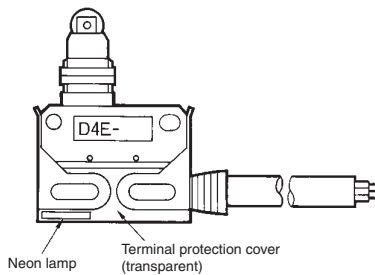

- There is no difference in operating characteristics between D4E-□N AC Models and corresponding D4E-□N Standard Models.
- There is no difference in dimensions between D4E-□N AC Models and D4E-□N Standard Models.

Example:

Add "L" at the front of "N", which is suffix of a part number.

Basic type: D4E-1A23N

When placing your order for the molded terminal model with an neon lamp operation indicator, specify the model number as D4E-1A23LN.

Internal Circuit

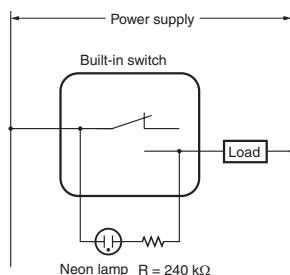

DC Operation

- LED indicator is provided.
- As a rectifier stack is incorporated, into the unit and no directionality exists for connection of + and -, this type can also be operated on AC.
- Voltage ratings of LED indicators are as shown in the table below.

Type	Voltage rating (V)	Leakage current (mA)	Internal resistance (kΩ)
L2	24	Approx. 1.2	18

Example:

Add "L2" at the front of "N", which is suffix of a part number.

Basic Model: The model number of the D4E-1A23N with a built-in 24-V LED indicator is D4E-1A23L2N.

Internal Circuit

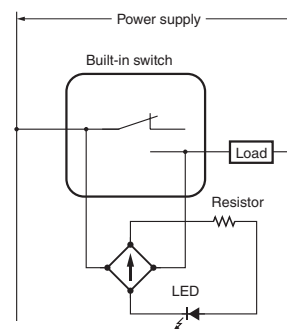

Safety Precautions

Refer to *Safety Precautions for All Limit Switches*.

Precautions for Correct Use

Operating Environment

- Seal material may deteriorate if a Switch is used outdoor or where subject to special cutting oils, solvents, or chemicals. Always appraise performance under actual application conditions and set suitable maintenance and replacement periods.
- Install Switches where they will not be directly subject to cutting chips, dust, or dirt. The Actuator and Switch must also be protected from the accumulation of cutting chips or sludge.

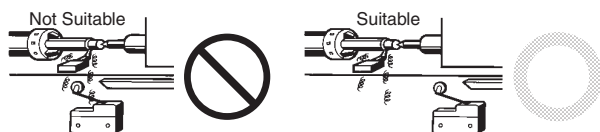

- Constantly subjecting a Switch to vibration or shock can result in wear, which can lead to contact interference with contacts, operation failure, reduced durability, and other problems. Excessive vibration or shock can lead to false contact operation or damage. Install Switches in locations not subject to shock and vibration and in orientations that will not produce resonance.
- The Switches have physical contacts. Using them in environments containing silicon gas will result in the formation of silicon oxide (SiO₂) due to arc energy. If silicon oxide accumulates on the contacts, contact interference can occur. If silicon oil, silicon filling agents, silicon cables, or other silicon products are present near the Switch, suppress arcing with contact protective circuits (surge killers) or remove the source of silicon gas.
- Do not solder the screw terminals.
- Sealing materials may deteriorate when used outdoors or when exposed to cutting oil, solvents, or chemicals. Check this on actual equipment and, if deterioration is foreseen, consult your OMRON representative in advance.
- If the one-touch connector is to be mounted onto the switch body, lightly push up the fitting so that the switch body can then be inserted into the clamp.

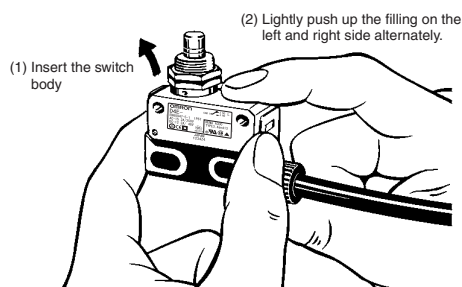

- Be sure that the clamp is inserted to the full depth, because the Switch will not function properly if one of the clamps is improperly inserted.

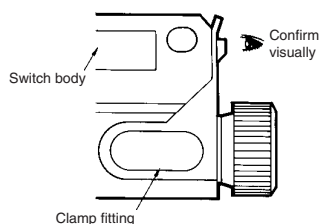

- If the clamp is properly inserted up to the full depth, it will not slide out easily. Be sure to carefully confirm all the above items.

- Be sure to connect a fuse with a breaking current 1.5 to 2 times the rated current to the Limit Switch in series in order to protect the Limit Switch from damage due to short-circuiting. When using the Limit under the EN ratings, use a gl or gG 10-A fuse that conforms to IEC60269.

Mounting

- Secure the Switch with two M4 screws and washers. The tightening torque applied to each terminal must be 1.18 to 1.37 N·m. Tighten the screws to the specified torque. An excessive tightening torque may damage the Switch and cause a malfunction.

Mounting Holes

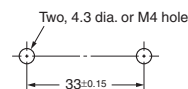

- When mounting the panel mount-type Switch with screws on a side surface, remove the hexagonal nuts from the actuator.
- When mounting the panel mount type on a panel, tighten the hexagonal nuts of the actuator to a torque less than 7.85 N·m.

Mounting Hole

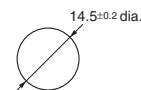

- Operating method, shape of cam or dog, operating frequency, and the overtravel (OT) have significant effect on the service life and precision of the Limit Switch. Make sure that the shape of the cam is smooth enough.
- Check that OT has a sufficient margin. The actual OT should be rated OT × 0.7 to 1.
- Do not change the operating position by remodeling the actuator.

Wiring

When wiring screw terminals, M3-size round solderless terminals with an insulation tube is recommended. The conductor size should be 0.75 mm² and cable diameter should be 7 mm.

Round solderless terminals

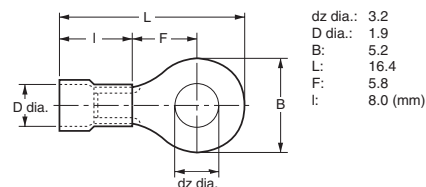

Wiring Method

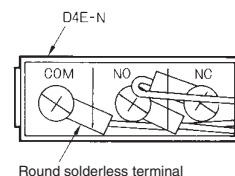

Tightening Torque

A loose screw may result in a malfunction. Be sure to tighten each screw to the proper tightening torque as shown below.

No.	Type	Appropriate tightening torque
(1)	Terminal screw (M3)	0.24 to 0.44 N·m
(2)	Switch mounting screw (M4)	1.18 to 1.37 N·m

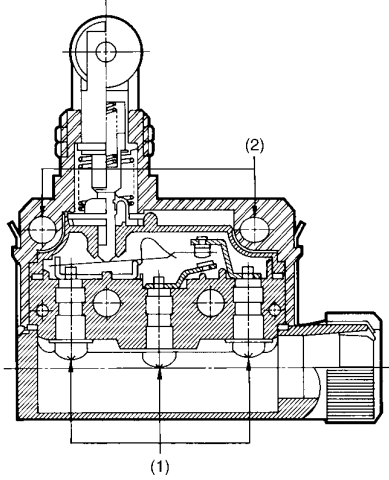

Read and Understand This Catalog

Please read and understand this catalog before purchasing the products. Please consult your OMRON representative if you have any questions or comments.

Warranty and Limitations of Liability

WARRANTY

OMRON's exclusive warranty is that the products are free from defects in materials and workmanship for a period of one year (or other period if specified) from date of sale by OMRON.

OMRON MAKES NO WARRANTY OR REPRESENTATION, EXPRESS OR IMPLIED, REGARDING NON-INFRINGEMENT, MERCHANTABILITY, OR FITNESS FOR PARTICULAR PURPOSE OF THE PRODUCTS. ANY BUYER OR USER ACKNOWLEDGES THAT THE BUYER OR USER ALONE HAS DETERMINED THAT THE PRODUCTS WILL SUITABLY MEET THE REQUIREMENTS OF THEIR INTENDED USE. OMRON DISCLAIMS ALL OTHER WARRANTIES, EXPRESS OR IMPLIED.

LIMITATIONS OF LIABILITY

OMRON SHALL NOT BE RESPONSIBLE FOR SPECIAL, INDIRECT, OR CONSEQUENTIAL DAMAGES, LOSS OF PROFITS OR COMMERCIAL LOSS IN ANY WAY CONNECTED WITH THE PRODUCTS, WHETHER SUCH CLAIM IS BASED ON CONTRACT, WARRANTY, NEGLIGENCE, OR STRICT LIABILITY.

In no event shall the responsibility of OMRON for any act exceed the individual price of the product on which liability is asserted.

IN NO EVENT SHALL OMRON BE RESPONSIBLE FOR WARRANTY, REPAIR, OR OTHER CLAIMS REGARDING THE PRODUCTS UNLESS OMRON'S ANALYSIS CONFIRMS THAT THE PRODUCTS WERE PROPERLY HANDLED, STORED, INSTALLED, AND MAINTAINED AND NOT SUBJECT TO CONTAMINATION, ABUSE, MISUSE, OR INAPPROPRIATE MODIFICATION OR REPAIR.

Application Considerations

SUITABILITY FOR USE

OMRON shall not be responsible for conformity with any standards, codes, or regulations that apply to the combination of products in the customer's application or use of the products.

At the customer's request, OMRON will provide applicable third party certification documents identifying ratings and limitations of use that apply to the products. This information by itself is not sufficient for a complete determination of the suitability of the products in combination with the end product, machine, system, or other application or use.

The following are some examples of applications for which particular attention must be given. This is not intended to be an exhaustive list of all possible uses of the products, nor is it intended to imply that the uses listed may be suitable for the products:

- Outdoor use, uses involving potential chemical contamination or electrical interference, or conditions or uses not described in this catalog.
- Nuclear energy control systems, combustion systems, railroad systems, aviation systems, medical equipment, amusement machines, vehicles, safety equipment, and installations subject to separate industry or government regulations.
- Systems, machines, and equipment that could present a risk to life or property.

Please know and observe all prohibitions of use applicable to the products.

NEVER USE THE PRODUCTS FOR AN APPLICATION INVOLVING SERIOUS RISK TO LIFE OR PROPERTY WITHOUT ENSURING THAT THE SYSTEM AS A WHOLE HAS BEEN DESIGNED TO ADDRESS THE RISKS, AND THAT THE OMRON PRODUCTS ARE PROPERLY RATED AND INSTALLED FOR THE INTENDED USE WITHIN THE OVERALL EQUIPMENT OR SYSTEM.

PROGRAMMABLE PRODUCTS

OMRON shall not be responsible for the user's programming of a programmable product, or any consequence thereof.

Disclaimers

CHANGE IN SPECIFICATIONS

Product specifications and accessories may be changed at any time based on improvements and other reasons.

It is our practice to change model numbers when published ratings or features are changed, or when significant construction changes are made. However, some specifications of the products may be changed without any notice. When in doubt, special model numbers may be assigned to fix or establish key specifications for your application on your request. Please consult with your OMRON representative at any time to confirm actual specifications of purchased products.

DIMENSIONS AND WEIGHTS

Dimensions and weights are nominal and are not to be used for manufacturing purposes, even when tolerances are shown.

PERFORMANCE DATA

Performance data given in this catalog is provided as a guide for the user in determining suitability and does not constitute a warranty. It may represent the result of OMRON's test conditions, and the users must correlate it to actual application requirements. Actual performance is subject to the OMRON Warranty and Limitations of Liability.

ERRORS AND OMISSIONS

The information in this document has been carefully checked and is believed to be accurate; however, no responsibility is assumed for clerical, typographical, or proofreading errors, or omissions.

2008.11

In the interest of product improvement, specifications are subject to change without notice.

OMRON Corporation
Industrial Automation Company

<http://www.ia.omron.com/>

(c)Copyright OMRON Corporation 2008 All Right Reserved.