

End-product drawing

6	7	8
REV.	DESCRIPTION	DESIGN DATE
(X1)	NEW DRAWING	PDH 2020/07/10

NOTES:

1. MATERIAL: PA66、BRASS、 SILICONE;
2. CERTIFICATION: ROHS/TUV/CE;
3. FIRE-PROOT: UL94-V2。
4. NO DEFECT IN APPEARANCE;
5. UNITS: mm;
6. CONDUCTION TEST: THE TWO ENDS OF THE 3 CORE JOINTS ARE RESPECTIVELY CONNECTED
7. A、 MAXIMUM CURRENT-CARRYING CAPACITY: 400V/24A  
 B、 TEST VOLTAGE: 2500V  
 C、 SUITABLE FOR CABLES CROSS SECTIONS: 0.5-2.5mm<sup>2</sup>  
 D、 OPERATING TEMPERATURE RANGE: -40~+105°C  
 E、 PROTECTION CLASS: IP68



2P/3P



Silicone parts

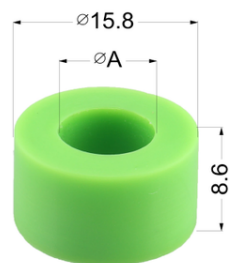

φA	Wire OD
φ11.5	φ9-12mm
φ8.5	φ5-9mm

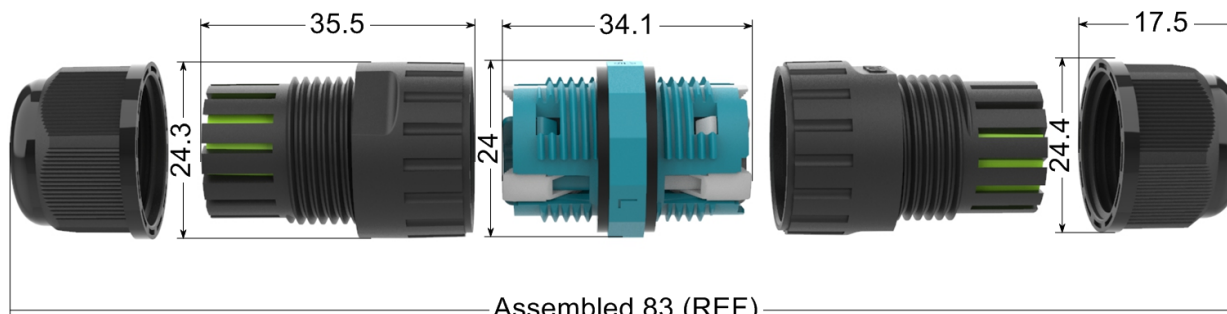

Assembled 83 (REF)

Weight	MEAS	Each carton number	G. W.
26.2g	42*30*34cm	600pcs	16.6Kg

UNLABELED TOLERANCE					UNITS	mm	DRAW	PDH 2020/07/10	PART NO.	EW-P20-3P	Fucon	
X.	±0.35	X.XX	±0.20		X.°	±2°	SCALE	1:1	CHKD			DWG NO
X.X	±0.25	X.XXX	±0.10		X.X°	±1°	SHEET	1/1	APPD			TITLE