



ACME Electronics Corporation
越峰電子材料股份有限公司

客户
CUSTOMER

PLATAN LLC

日期
DATE 2023/11/21

认 可 书
SPECIFICATION FOR APPROVAL

客户品名 CUSTOMER P/N	HLD-PM-114/93	
越峰品名 ACME P/N	AMAOT23308BX-W	
版本号 REV. NO.	0	

为保证订单顺利完成，请在一个月内签回。否则，将默认贵司同意依此份认可书内容制作您所有此规格的订单产品。

In order to ensure the leadtime for your order, pls confirm and sign this spec for ACME within one month while you received it. Or else, it means that you have approved this spec, and you have agreed with that ferrite cores from your order be produced according to this spec.

客户认可 APPROVED BY :

如有客户品码（料号），请填写在下
 客户品码（料号）：
 CUSTOMER P/N

- 厂别 Factory
- 总公司：台北市内湖区基湖路39号8楼B室
 Head Office: 8th Floor, No.39, Ji-Hu Rd., Nei-Hu Dist., Taipei 114, Taiwan, R.O.C.
 Tel: +886-2-2798-0337 Fax: +886-2-2659-9511 E-Mail: sales@acme-ferrite.com.tw
 - 观音厂：台湾省桃园县328观音工业区国建二路2号
 No.2, Kuo-Chien 2nd Rd, Kuan-Yin Industrial District, Taoyuan County 328, Taiwan, R.O.C.
 Tel: +886-3-483-7238 Fax: +886-3-483-7239
 - 广州厂：越峰电子(广州)有限公司 / 中国广东省广州增城市增江街东区府前东路2号
 No.2 Fuqian East Road, Zengjiang Street East Square, Guangzhou-Zengcheng City,
 Guangdong Province, China.
 Tel: +86-20-3285-1888 Fax: +86-20-3285-1666
 - 昆山厂：越峰电子(昆山)有限公司 / 中国江苏省昆山市黄浦江北路533号
 No.533, Huangpujiang North Rd., Kunshan City
 Tel: +86-512-5793-2888 Fax: +86-512-5766-4667

批准	审核	拟制
APPROVED BY	CHECKED BY	PREPARED BY
Jeff	Jeff	Jackson



ACME Electronics Corporation
越峰電子材料股份有限公司

历史变更记录
REVISION RECORDS LIST

客户 CUSTOMER:	PLATAN LLC	CUSTOMER P/N	HLD-PM-114/93
		ACME P/N	AMAOT23308BX-W

更改记录 REVISION RECORD:

版本号 REV. NO.	更改内容及原因 CONTENTS AND REASONS	日期 DATE OF APPROVAL	担当 DRAWN
0	NEW SPEC	2023/11/21	Jeff Liu



1.外形尺寸Outer Dimension(mm)

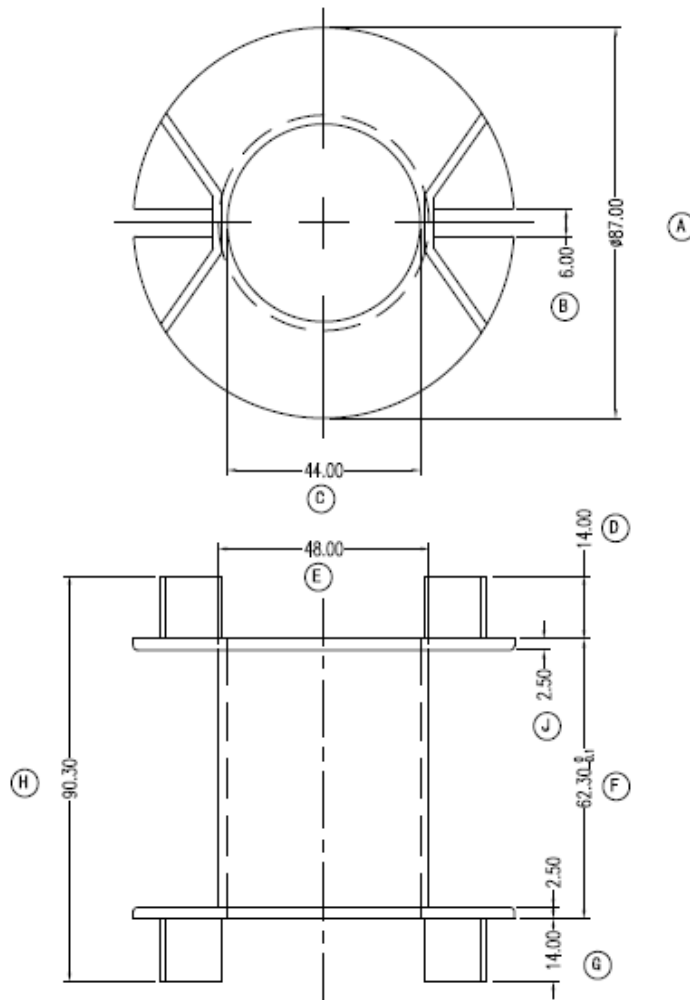

DRAWING	Mico Deng	TOLERANCE		MODEL	HLD-PM-114/93		
		0<X<4	± 0.1				
CHECKED APPROVED	CHEN SONGHUA	4<X<15	± 0.2	ANGLE:	TITLE: BOBBIN		
		15<X<35	± 0.3				
		X>35	± 0.4				
PIN PITCH ± 0.2				UNIT: MM	BOBBIN MATERIAL	Phenolic	
ACME Electronics Corporation				SCALE: 1/1	PIN MATERIAL:	CP Wire	
						DATE: 04.12.01	UL 94V-0

CUSTOMER P/N	HLD-PM-114/93
ACME P/N	AMAOT23308BX-W

版本号REV: 0

