

## *Installation Instructions*

# MicroLogix™ 1500 Programmable Controller Base Units

(Catalog Numbers 1764-24AWA, 1764-24BWA, and  
1764-28BxB)

---

[http://literature.rockwellautomation.com/idc/groups/literature/documents/in/1764-in001\\_-mu-p.pdf](http://literature.rockwellautomation.com/idc/groups/literature/documents/in/1764-in001_-mu-p.pdf)

---

**FR**

Cette publication est disponible en français sous forme électronique (fichier PDF). Pour la télécharger, rendez-vous sur la page Internet indiquée ci-dessus.

**IT**

Questa pubblicazione è disponibile in Italiano in formato PDF. Per scaricarla collegarsi al sito Web indicato sopra.

**DE**

Diese Publikation ist als PDF auf Deutsch verfügbar. Gehen Sie auf die oben genannte Web-Adresse, um nach der Publikation zu suchen und sie herunterzuladen.

**ES**

Esta publicación está disponible en español como PDF. Diríjase a la dirección web indicada arriba para buscar y descarga esta publicación.

**PT**

Esta publicação está disponível em português como PDF. Vá ao endereço web que aparece acima para encontrar e fazer download da publicação.

---





## *Installation Instructions*

# MicroLogix™ 1500 Programmable Controller Base Units

(Catalog Numbers 1764-24AWA, 1764-24BWA, and  
1764-28BXB)

Inside...	
For More Information .....	4
Overview .....	5
Base Unit Description .....	6
Hazardous Location Considerations .....	7
Mounting the Controller .....	9
Wiring the Controller .....	13
Specifications .....	17

## For More Information

**Table 1 Related Publications**

<b>For</b>	<b>Refer to this Document</b>	<b>Pub. No.</b>
A more detailed description of how to install and use your MicroLogix 1500 programmable controller.	MicroLogix 1500 Programmable Controllers User Manual	1764-UM001A-US-P
A reference manual that contains data and function files, instruction set, and troubleshooting information for MicroLogix 1200 and MicroLogix 1500.	MicroLogix 1200 and MicroLogix 1500 Instruction Set Reference Manual	1762-RM001B-US-P
More information on proper wiring and grounding techniques.	Industrial Automation Wiring and Grounding Guidelines	1770-4.1

If you would like a manual, you can:

- download a free electronic version from the internet:  
<http://literature.rockwellautomation.com>
- purchase a printed manual by contacting your local Allen-Bradley distributor or Rockwell Automation representative

## Overview

Install your controller using these installation instructions.

**ATTENTION**

Do not remove protective debris strips until after the base and all other equipment in the panel near the base is mounted and wiring is complete. Once wiring is complete, remove protective debris strips and install processor unit. Failure to remove strips before operating can cause overheating.

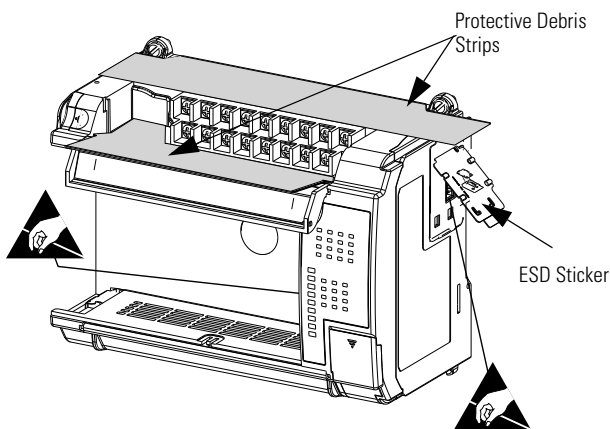
**ATTENTION**

Be careful of metal chips when drilling mounting holes for your controller or other equipment within the enclosure or panel. Drilled fragments that fall into the controller could cause damage. Do not drill holes above a mounted controller if the protective debris strips have been removed.

**ATTENTION**

Electrostatic discharge can damage semiconductor devices inside the base unit. Do not touch the connector pins or other sensitive areas.

# Base Unit Description

**Table 2 Standard Base Units**

Catalog Number	Base Unit I/O and Power Supply
1764-24AWA	120V ac inputs/ relay outputs/ 120/240V ac power supply
1764-24BWA	24V dc inputs/ relay outputs/ 120/240V ac power supply
1764-28BXB	24V dc inputs/ FET and relay outputs/ 24V dc power supply

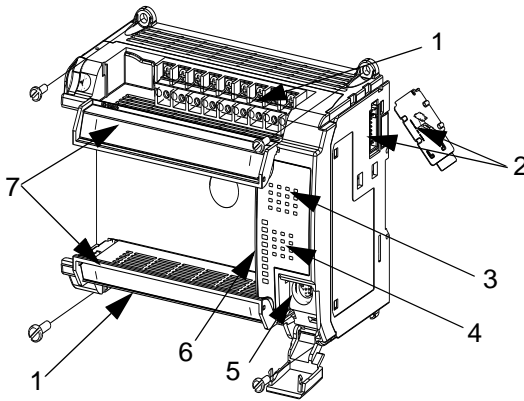
**Table 3 Base Unit Description**

Feature	Description
1	Removable Terminal Blocks
2	Interface to Expansion I/O, Removable ESD Sticker
3	Input LEDs
4	Output LEDs
5	RS-232 Communication Port (CH0)
6	Status LEDs
7	Terminal Doors and Label

## Hazardous Location Considerations

This equipment is suitable for use in Class I, Division 2, Groups A, B, C, D or non-hazardous locations only. The following WARNING statement applies to use in hazardous locations.

**WARNING**
**EXPLOSION HAZARD**

- Substitution of components may impair suitability for Class I, Division 2.
- Do not replace components or disconnect equipment unless power has been switched off or the area is known to be non-hazardous.
- Do not connect or disconnect components unless power has been switched off or the area is known to be non-hazardous.
- This product must be installed in an enclosure. All cables connected to the product must remain in the enclosure or be protected by conduit or other means.
- All wiring must comply with N.E.C. article 501-4(b).

Use only the following communication cables in Class I, Division 2 hazardous locations.

**Table 4 Cable Listing**

<b>Environment Classification</b>	<b>Communication Cables</b>
Class I, Division 2 Hazardous Environment	1761-CBL-PM02 Series C or later
	1761-CBL-HM02 Series C or later
	1761-CBL-AM00 Series C or later
	1761-CBL-AP00 Series C or later
	2707-NC8 Series B or later
	2707-NC10 Series B or later
	2707-NC11 Series B or later

## Environnements dangereux

Cet équipement est conçu pour être utilisé dans des environnements de Classe 1, Division 2, Groupes A, B, C, D ou non dangereux. La mise en garde suivante s'applique à une utilisation dans des environnements dangereux.

### MISE EN GARDE



### DANGER D'EXPLOSION

- La substitution de composants peut rendre cet équipement impropre à une utilisation en environnement de Classe 1, Division 2.
- Ne pas remplacer de composants ou déconnecter l'équipement sans s'être assuré que l'alimentation est coupée et que l'environnement est classé non dangereux.
- Ne pas connecter ou déconnecter des composants sans s'être assuré que l'alimentation est coupée ou que l'environnement est classé non dangereux.
- Ce produit doit être installé dans une armoire. Tous les câbles qui lui sont connectés doivent rester dans l'armoire ou être protégés par un conduit ou par d'autres moyens.

N'utilisez que les câbles de communication suivants dans des environnements dangereux de Classe 1, Division 2.

**Table 5 Liste des câbles**

Classification d'environnement	Câbles de communication
Environnement dangereux Classe 1, Division 2	1761-CBL-PM02, série C ou ultérieure
	1761-CBL-HM02, série C ou ultérieure
	1761-CBL-AM00, série C ou ultérieure
	1761-CBL-AP00, série C ou ultérieure
	2707-NC8, série B ou ultérieure
	2707-NC10, série B ou ultérieure
	2707-NC11, série B ou ultérieure



---

# Mounting the Controller

## General Considerations

Most applications require installation in an industrial enclosure (Pollution Degree 2) to reduce the effects of electrical interference (Over Voltage Category II) and environmental exposure. Locate your controller as far as possible from power lines, load lines, and other sources of electrical noise such as hard-contact switches, relays, and AC motor drives. For more information on proper grounding guidelines, see the *Industrial Automation Wiring and Grounding Guidelines* publication 1770-4.1.

---

### ATTENTION



Vertical mounting is not recommended due to heat build-up considerations.

---

### ATTENTION



Be careful of metal chips when drilling mounting holes for your controller or other equipment within the enclosure or panel. Drilled fragments that fall into the base or processor unit could cause damage. Do not drill holes above a mounted controller if the protective debris strips have been removed or the processor has been installed.

---

### NOTE

Remove the ESD sticker to install expansion I/O modules. An end cap terminator (catalog numbers 1769-ECR or -ECL) or an extension cable (catalog numbers 1769-CRR1, -CRR3, -CLL1, -CLL3, -CRL1, -CRL3) must be used at the end of the group of I/O modules attached to the MicroLogix 1500 Controller. The end cap terminator is not provided with the base unit. A maximum of eight I/O modules may be connected to the base.

## Mounting Dimensions

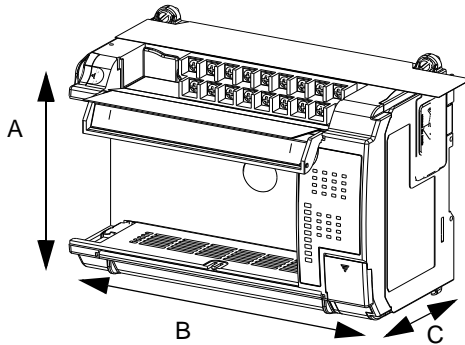
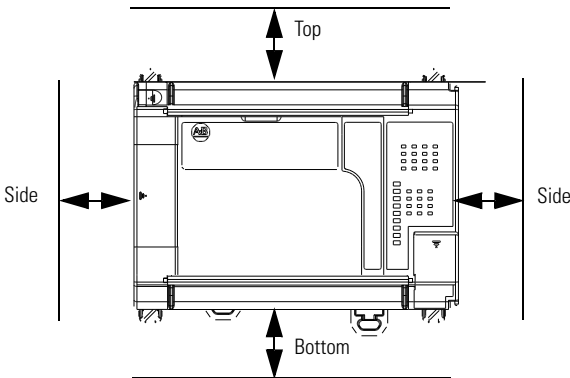

**Table 6 Dimensions**

Dimension	1764-24AWA	1764-24BWA	1764-28BXB
Height (A)	138 mm (5.43 in.)		
Width (B)	168 mm (6.62 in.)		
Depth (C)	87 mm (3.43 in.)		

## Controller Spacing

The base unit is designed to be mounted horizontally, with the Compact™ expansion I/O extending to the right of the base unit. Allow 50 mm (2 in.) of space on all sides for adequate ventilation, as shown below.



## Using a DIN Rail

The base unit and expansion I/O DIN rail latches lock in the open position so that an entire system can be easily attached to or removed from the DIN rail. The maximum extension of the latch is 15 mm (0.67 in.) in the open position. A flat-blade screw driver is required for removal of the base unit. The base can be mounted to EN50022-35x7.5 or EN50022-35x15 DIN rails. DIN rail mounting dimensions are shown below.

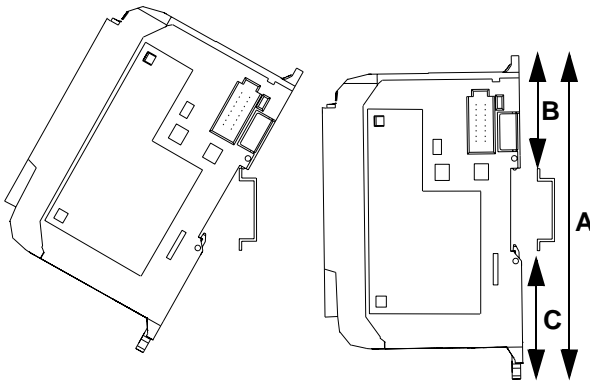

**Table 7 DIN Rail Mounting Dimensions**

Dimension	Height
A	138 mm (5.43 in.)
B	47.6 mm (1.875 in.)
C	47.6 mm (1.875 in.) DIN latch closed 54.7 mm (2.16 in.) DIN latch open

To install your base unit on the DIN rail:

1. Mount your DIN rail. (Make sure that the placement of the base unit on the DIN rail meets the recommended spacing requirements, see “Controller Spacing” on page 10. Refer to the mounting template from the inside back cover of this document.)
2. Hook the top slot over the DIN rail.
3. While pressing the base unit down against the top of the rail, snap the bottom of the base unit into position.
4. Leave the protective debris strip attached until you are finished wiring the base unit and any other devices.

To remove your base unit from the DIN rail:

1. Place a flat-blade screwdriver in the DIN rail latch at the bottom of the base unit.
2. Holding the base unit, pry downward on the latch until the latch locks in the open position. This releases the base unit from the DIN rail.

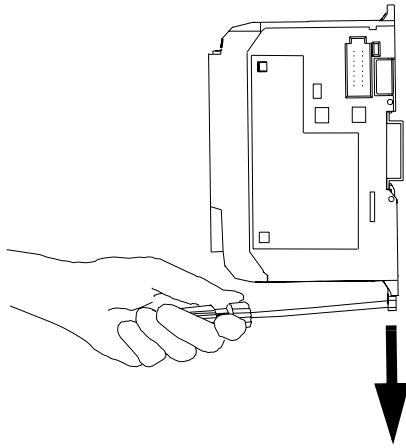

## Using Mounting Screws

Mount to panel using #8 or M4 screws.

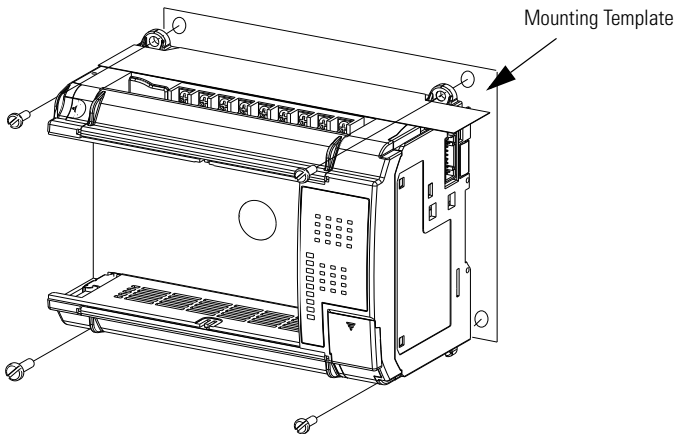

To install your base unit using mounting screws:

1. Remove the mounting template from the inside back cover of this document.
2. Secure the template to the mounting surface. (Make sure your base unit is spaced properly, see “Controller Spacing” on page 10).
3. Drill holes through the template.
4. Remove the mounting template.
5. Mount the base unit.
6. Leave the protective debris strips attached until you are finished wiring the base unit and any other devices.

## Wiring the Controller

### Terminal Block Layout

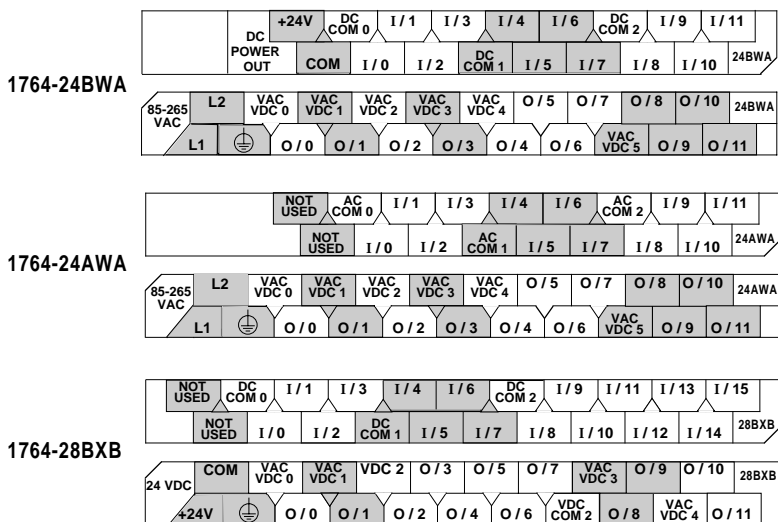

## Wire Requirements

**Table 8 Wire Type Recommendation**

Wire Type		Wire Size (2 wire maximum per terminal screw)
Solid	Cu-90°C (194°F)	#14 to #22 AWG
Stranded	Cu-90°C (194°F)	#14 to #22 AWG

Wiring torque = 1.13 Nm (10 in-lb) rated; 1.3 Nm (12 in-lb) maximum

**ATTENTION**



Be careful when stripping wires. Wire fragments that fall into the controller could cause damage. Once wiring is complete, be sure the base unit is free of all metal fragments before removing protective debris strips and installing the processor unit. Failure to remove strips before operating can cause overheating.

## Wiring Recommendation

When wiring without spade lugs, keep the finger-safe covers in place. Loosen the terminal screw and route the wires through the opening in the finger-safe cover. Tighten the terminal screw making sure the pressure plate secures the wire.

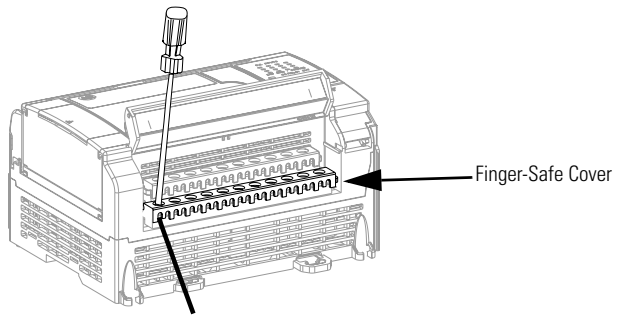

## Spade Lug Recommendation

The diameter of the terminal screw head is 5.5 mm (0.220 in.). The input and output terminals of the MicroLogix 1500 base unit are designed for the following spade lugs. The terminals will accept a 6.35mm (0.25 in.) wide spade (standard for #6 screw for up to 14 AWG) or a 4 mm (metric #4) fork terminal.

When using spade lugs, use a small, flat-blade screwdriver to pry the finger-safe cover from the terminal blocks, then loosen the terminal screw.

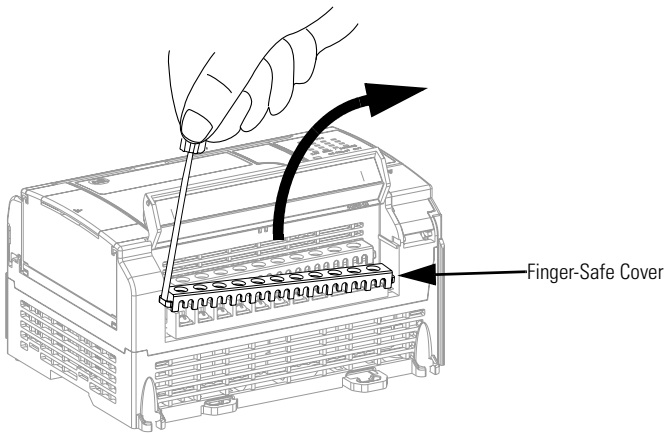

## Surge Suppression

### ATTENTION



Inductive load devices such as motor starters and solenoids require the use of some type of surge suppression to protect the controller output. Switching inductive loads without surge suppression can significantly reduce the lifetime of relay contacts or damage transistor outputs. By using suppression, you also reduce the effects of voltage transients caused by interrupting the current to that inductive device, and prevent electrical noise from radiating into system wiring.

## Grounding the Controller

---

**ATTENTION**



All devices connected to the RS-232 channel must be referenced to base unit ground or floating. Failure to follow this procedure may result in property damage or personal injury.

---

In solid-state control systems, grounding and wire routing helps limit the effects of noise due to electromagnetic interference (EMI). Run the ground connection from the ground screw of the base unit to the ground bus prior to connecting any devices. Use AWG #14 wire. This connection must be made for safety purposes.

You must also provide an acceptable grounding path for each device in your application. For more information on proper grounding guidelines, see the *Industrial Automation Wiring and Grounding Guidelines* publication 1770-4.1.



# Specifications

**Table 9 General Specifications**

Description	1764-24BWA	1764-24AWA	1764-28BXB
Number of I/O	12 inputs 12 outputs	12 inputs 12 outputs	16 inputs 12 outputs
Line Power	85/265V ac	85/265V ac	20.4 to 30V dc
Power Supply Inrush	120V ac = 25A for 8 ms  240V ac = 40A for 4 ms	120V ac = 25A for 8 ms  240V ac = 40A for 4 ms	24V dc = 4A for 150 ms
User Power Output	24V dc at 400 mA, 400 µf max.	none	none
Input Circuit Type	24V dc, sink/source	120V ac	24V dc, sink/source
Output Circuit Type	relay	relay	6 relay, 6 FET transistor
Operating Temp.	+0°C to +55°C (+32°F to +131°F) ambient		
Storage Temp.	-40°C to +85°C (-40°F to +185°F) ambient		
Operating Humidity	5% to 95% relative humidity (non-condensing)		
Vibration	Operating: 10 to 500 Hz, 5G, 0.015 in. peak-to-peak Relay Operation: 2G		
Shock (without Data Access Tool installed)	Operating: 30G panel mounted (15G DIN Rail mounted) Relay Operation: 7.5G panel mounted (5G DIN Rail mounted) Non-Operating: 40G panel mounted (30G DIN Rail mounted)		
Shock (with Data Access Tool installed)	Operating: 20G panel mounted (15g DIN Rail mounted) Relay Operation: 7.5G panel mounted (5G DIN Rail mounted) Non-Operating: 30G panel mounted (20G DIN Rail mounted)		
Agency Certification	<ul style="list-style-type: none"> <li>• UL 508</li> <li>• C-UL under CSA C22.2 no. 142</li> <li>• Class I, Div. 2, Groups A, B, C, D (UL 1604, C-UL under CSA C22.2 no. 213)</li> <li>• CE compliant for all applicable directives</li> </ul>		
Terminal Screw Torque	1.13 Nm (10 in-lb) rated; 1.3 Nm (12 in-lb) maximum		
Power Supply Isolation	2596V dc	2596V dc	1697V dc
Relay Outputs Isolation	2596V dc	2596V dc	2596V dc
Transistor Output Isolation	none	none	1697V dc
Inputs Isolation	2145V dc	2145V dc	1697V dc
User 24V Isolation	848V dc	none	none

**Table 10 Input Specifications**

Description	1764-24AWA	1764-24BWA and 1764-28BXB	
		Inputs 0 thru 7	Inputs 8 and Higher
On State Voltage Range	79 to 132V ac	14 to 30.0 V dc at 30°C (86°F) 14 to 26.4 V dc at 55°C (131°F)	10 to 30.0 V dc at 30°C (86°F) 10 to 26.4 V dc at 55°C (131°F)
Off State Voltage Range	0 to 20V ac	0 to 5V dc	
Operating Frequency	47 Hz to 63 Hz	0 Hz to 20 KHz (1764-24BWA)	0 Hz to 1 KHz <sup>(1)</sup> (1764-24BWA)
On State Current:			
<ul style="list-style-type: none"> <li>• minimum</li> <li>• nominal</li> <li>• maximum</li> </ul>	<ul style="list-style-type: none"> <li>• 5.0 mA at 79V ac</li> <li>• 12.0 mA at 120V ac</li> <li>• 16.0 mA at 132V ac</li> </ul>	<ul style="list-style-type: none"> <li>• 2.5 mA at 14V dc</li> <li>• 7.3 mA at 24V dc</li> <li>• 12.0 mA at 30V dc</li> </ul>	<ul style="list-style-type: none"> <li>• 2.0 mA at 10V dc</li> <li>• 8.9 mA at 24V dc</li> <li>• 12.0 mA at 30V dc</li> </ul>
Off State Leakage Current	2.5 mA minimum	1.5 mA minimum	
Nominal Impedance	12k ohms at 50 Hz 10k ohms at 60 Hz	3.3k ohms	2.7k ohms
Inrush Current (max.) at 120V ac	250 mA	Not Applicable	Not Applicable

(1) Scan-time dependant.

**Table 11 Output Specifications**

Specification		1764-24AWA/BWA	1764-28BXB
Current per Common		8A	8A
Current per Controller	at 150V Maximum	24A	18A
	at 240V Maximum	20A	18A

**Table 12 Relay Contact Rating Table 1764-24AWA, -24BWA, -28BXB**

Maximum Volts	Amperes		Amperes Continuous	Voltamperes	
	Make	Break		Make	Break
240V ac	7.5A	0.75A	2.5A	1800 VA	180 VA
120V ac	15A	1.5A			
125V dc	0.22A <sup>(1)</sup>		1.0A	28 VA	
24V dc	1.2A <sup>(1)</sup>		2.0A	28 VA	

(1) For dc voltage applications, the make/break ampere rating for relay contacts can be determined by dividing 28 VA by the applied dc voltage. For example, 28 VA/48V dc = 0.58A. For dc voltage applications less than 48V, the make/break ratings for relay contacts cannot exceed 2A

**Table 13 1764-28BXB FET Output Specifications**

Specification		General Operation (Outputs 2 thru 7)	High Speed Operation <sup>(1)</sup> (Outputs 2 and 3 Only)
User Supply Voltage	minimum	20.4V dc	20.4V dc
	maximum	26.4V dc	26.4V dc
On-State Voltage Drop	at maximum load current	1V dc	Not Applicable
	at maximum surge current	2.5V dc	Not Applicable
Current Rating per Point	maximum load	1A at 55°C (131°F) 1.5A at 30°C (86°F)	100 mA
	minimum load	1.0 mA	10 mA
	maximum leakage	1.0 mA	1.0 mA
Surge Current per Point	peak current	4.0A	Not Applicable
	maximum surge duration	10 msec	Not Applicable
	maximum rate of repetition at 30°C (86°F)	once every second	Not Applicable
	maximum rate of repetition at 55°C (131°F)	once every 2 seconds	Not Applicable
Current per Common	maximum total	6A	6A
Turn-On Time	maximum	0.1 msec	6 µsec
Turn-Off Time	maximum	1.0 msec	18 µsec
Repeatability	maximum	n/a	2 µsec
Drift	maximum	n/a	1 µsec per 5°C (1 µsec per 9°F)

(1) Outputs 2 and 3 are designed to provide increased functionality over the other FET outputs (4 through 7). They may be used like the other FET transistor outputs, but in addition, within a limited current range, they may be operated at a higher speed. Outputs 2 and 3 also provide a pulse train output (PTO) or pulse width modulation output (PWM) function.

**Table 14 Working Voltage**

<b>Specification</b>	<b>1764-L24AWA</b>
Power Supply Input to Backplane Isolation	Verified by one of the following dielectric tests: 1836V ac for 1 second or 2596V dc for 1 second
	265V Working Voltage (IEC Class 2 reinforced insulation)
Input Group to Backplane Isolation and Input Group to Input Group Isolation	Verified by one of the following dielectric tests: 151V ac for 1 second or 2145V dc for 1 second
	132V Working Voltage (IEC Class 2 reinforced insulation)
Output Group to Backplane Isolation	Verified by one of the following dielectric tests: 1836V ac for 1 second or 2596V dc for 1 second
	265V Working Voltage (IEC Class 2 reinforced insulation)
Output Group to Output Group Isolation	Verified by one of the following dielectric tests: 1836V ac for 1 second or 2596V dc for 1 second
	265V Working Voltage (basic insulation) 150V Working Voltage (IEC Class 2 reinforced insulation).
<b>Specification</b>	<b>1764-24BWA</b>
Power Supply Input to Backplane Isolation	Verified by one of the following dielectric tests: 1836V ac for 1 second or 2596V dc for 1 second
	265V Working Voltage (IEC Class 2 reinforced insulation)
Power Supply User 24V Output to Backplane Isolation	Verified by one of the following dielectric tests: 600V ac for 1 second or 848V dc for 1 second
	50V Working Voltage (IEC Class 2 reinforced insulation)
Input Group to Backplane Isolation and Input Group to Input Group Isolation	Verified by one of the following dielectric tests: 1200V ac for 1 second or 1697V dc for 1 second
	75V dc Working Voltage (IEC Class 2 reinforced insulation)
Output Group to Backplane Isolation	Verified by one of the following dielectric tests: 1836V ac for 1 second or 2596V dc for 1 second
	265V Working Voltage (IEC Class 2 reinforced insulation).
Output Group to Output Group Isolation.	Verified by one of the following dielectric tests: 1836V ac for 1 second or 2596V dc for 1 second
	265V Working Voltage (basic insulation) 150V Working Voltage (IEC Class 2 reinforced insulation)

**Table 14 Working Voltage**

<b>Specification</b>	<b>1764-28BXB</b>
Input Group to Backplane Isolation and Input Group to Input Group Isolation	Verified by one of the following dielectric tests: 1200V ac for 1 second or 1697V dc for 1 second
	75V dc Working Voltage (IEC Class 2 reinforced insulation)
FET Output Group to Backplane Isolation and FET Outputs Group to Group	Verified by one of the following dielectric tests: 1200V ac for 1 second or 1697V dc for 1 second
	75V dc Working Voltage (IEC Class 2 reinforced insulation)
Relay Output Group to Backplane Isolation	Verified by one of the following dielectric tests: 1836V ac for 1 second or 2596V dc for 1 second
	265V Working Voltage (IEC Class 2 reinforced insulation)
Relay Output Group to Relay and FET Output Group Isolation	Verified by one of the following dielectric tests: 1836V ac for 1 second or 2596V dc for 1 second
	265V Working Voltage (basic insulation) 150V Working Voltage (IEC Class 2 reinforced insulation)

## Notes:

## Notes:

## Notes:



## Notes:

# Mounting Template

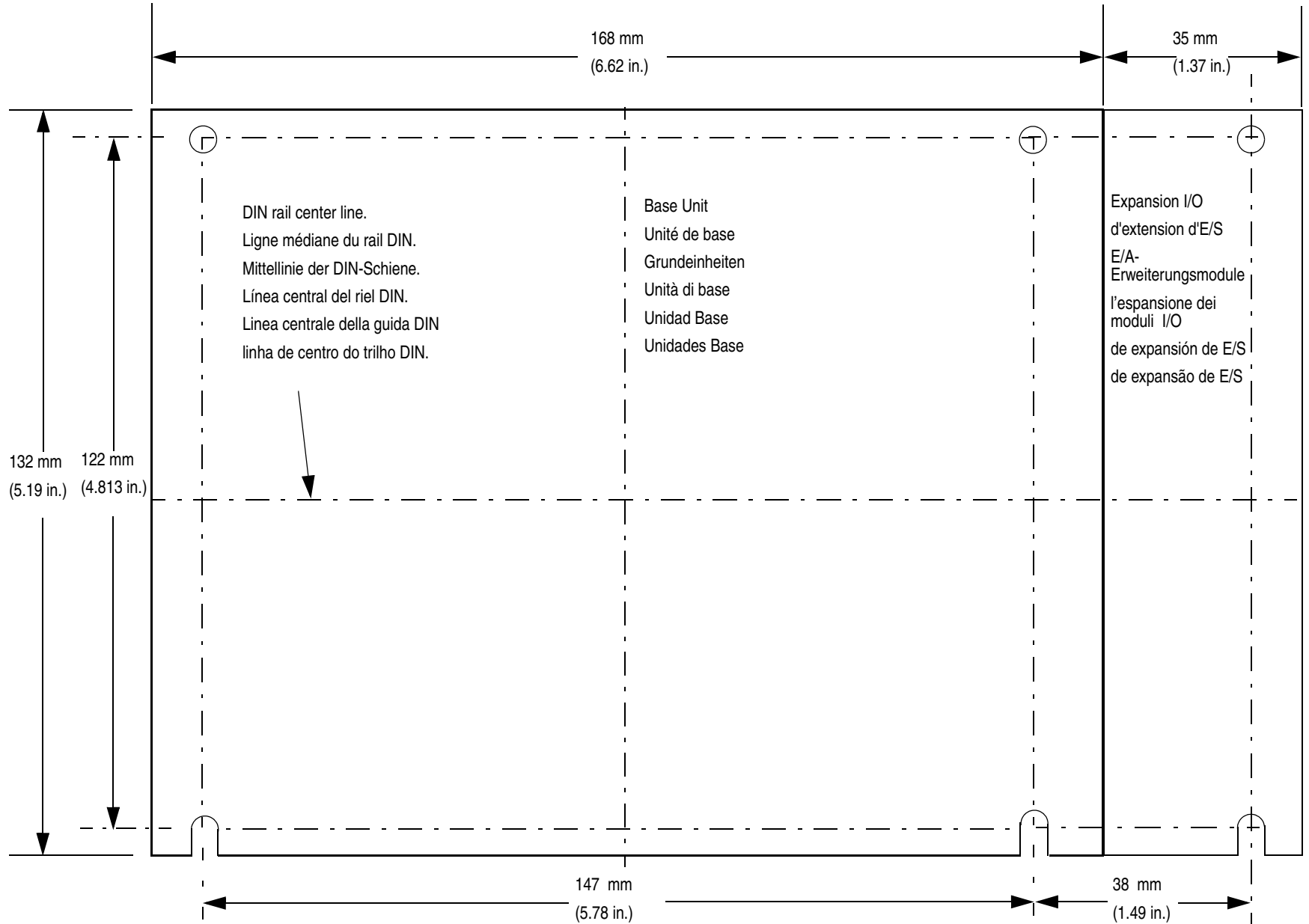

# Rockwell Automation Support

Rockwell Automation provides technical information on the Web to assist you in using its products. At <http://support.rockwellautomation.com>, you can find technical manuals, a knowledge base of FAQs, technical and application notes, sample code and links to software service packs, and a MySupport feature that you can customize to make the best use of these tools.

For an additional level of technical phone support for installation, configuration and troubleshooting, we offer TechConnect support programs. For more information, contact your local distributor or Rockwell Automation representative, or visit <http://support.rockwellautomation.com>.

## Installation Assistance

If you experience a problem with a hardware module within the first 24 hours of installation, please review the information that's contained in this manual. You can also contact a special Customer Support number for initial help in getting your module up and running:

United States	1.440.646.3434 Monday – Friday, 8am – 5pm EST
Outside United States	Please contact your local Rockwell Automation representative for any technical support issues.

## New Product Satisfaction Return

Rockwell Automation tests all of its products to ensure that they are fully operational when shipped from the manufacturing facility. However, if your product is not functioning and needs to be returned, follow these procedures.

United States	Contact your distributor. You must provide a Customer Support case number (see phone number above to obtain one) to your distributor in order to complete the return process.
Outside United States	Please contact your local Rockwell Automation representative for return procedure.

Allen-Bradley, Rockwell Automation, MicroLogix, and TechConnect are trademarks of Rockwell Automation, Inc.

Trademarks not belonging to Rockwell Automation are property of their respective companies.

[www.rockwellautomation.com](http://www.rockwellautomation.com)

### Power, Control and Information Solutions Headquarters

Americas: Rockwell Automation, 1201 South Second Street, Milwaukee, WI 53204-2496 USA, Tel: (1) 414.382.2000, Fax: (1) 414.382.4444  
Europe/Middle East/Africa: Rockwell Automation, Vorstlaan/Boulevard du Souverain 36, 1170 Brussels, Belgium, Tel: (32) 2 663 0600, Fax: (32) 2 663 0640  
Asia Pacific: Rockwell Automation, Level 14, Core F, Cyberport 3, 100 Cyberport Road, Hong Kong, Tel: (852) 2887 4788, Fax: (852) 2508 1846

Publication 1764-IN001B-EN-P - March 2008

Supersedes Publication 1764-IN001A-EN-P - September 2007

PN 40072-089-01(C)

Copyright © 2008 Rockwell Automation, Inc. All rights reserved. Printed in Singapore.

