

Compact PLC series

# CPM1A

Ultracompact and Economical ... For a Wide Range of Uses  
AC or DC power, relay or transistor outputs, sourcing or sinking, etc.

## SYSMAC CPM1A



Setting a standard for micro PLCs, the CPM1A packs all basic functions into a compact size. Four CPU sizes are available, each with a choice of AC or DC power, relay or transistor outputs. Select any combination of power supply, output, and the number of I/O points to meet your needs.

AC Power Source CPU Units    Depth: 70 mm		DC Power Source CPU Units    Depth: 50 mm	
<ul style="list-style-type: none"> <li>■ Relay Output CPU Unit CPM1A-10CDR-A-V1</li> <li>■ Transistor Output CPU Units CPM1A-10CDT-A-V1 (Sink) CPM1A-10CDT1-A-V1 (Source)</li> <li>● Input points: 6, DC input</li> <li>● Output points: 4</li> </ul>	<ul style="list-style-type: none"> <li>■ Relay Output CPU Unit CPM1A-20CDR-A-V1</li> <li>■ Transistor Output CPU Units CPM1A-20CDT-A-V1 (Sink) CPM1A-20CDT1-A-V1 (Source)</li> <li>● Input points: 12, DC input</li> <li>● Output points: 8</li> </ul>	<ul style="list-style-type: none"> <li>■ Relay Output CPU Unit CPM1A-10CDR-D-V1</li> <li>■ Transistor Output CPU Units CPM1A-10CDT-D-V1 (Sink) CPM1A-10CDT1-D-V1 (Source)</li> <li>● Input points: 6, DC input</li> <li>● Output points: 4</li> </ul>	<ul style="list-style-type: none"> <li>■ Relay Output CPU Unit CPM1A-20CDR-D-V1</li> <li>■ Transistor Output CPU Units CPM1A-20CDT-D-V1 (Sink) CPM1A-20CDT1-D-V1 (Source)</li> <li>● Input points: 12, DC input</li> <li>● Output points: 8</li> </ul>
<ul style="list-style-type: none"> <li>■ Relay Output CPU Unit CPM1A-30CDR-A-V1</li> <li>● Transistor Output CPU Units CPM1A-30CDT-A-V1 (Sink) CPM1A-30CDT1-A-V1 (Source)</li> <li>● Input points: 18, DC input</li> <li>● Output points: 12</li> </ul>	<ul style="list-style-type: none"> <li>■ Relay Output CPU Unit CPM1A-40CDR-A-V1</li> <li>■ Transistor Output CPU Units CPM1A-40CDT-A-V1 (Sink) CPM1A-40CDT1-A-V1 (Source)</li> <li>● Input points: 24, DC input</li> <li>● Output points: 16</li> </ul>	<ul style="list-style-type: none"> <li>■ Relay Output CPU Unit CPM1A-30CDR-D-V1</li> <li>■ Transistor Output CPU Units CPM1A-30CDT-D-V1 (Sink) CPM1A-30CDT1-D-V1 (Source)</li> <li>● Input points: 18, DC input</li> <li>● Output points: 12</li> </ul>	<ul style="list-style-type: none"> <li>■ Relay Output CPU Unit CPM1A-40CDR-D-V1</li> <li>■ Transistor Output CPU Units CPM1A-40CDT-D-V1 (Sink) CPM1A-40CDT1-D-V1 (Source)</li> <li>● Input points: 24, DC input</li> <li>● Output points: 16</li> </ul>

### Expansion I/O Units

<ul style="list-style-type: none"> <li>CPM1A-8ED</li> <li>● Input points: 8, DC input</li> </ul>	<ul style="list-style-type: none"> <li>CPM1A-8ER</li> <li>● Output points: 8, RY output</li> </ul>	<ul style="list-style-type: none"> <li>CPM1A-8ET</li> <li>● Output points: 8, TR output (Sink)</li> </ul>	<ul style="list-style-type: none"> <li>CPM1A-8ET1</li> <li>● Output points: 8, TR output (Source)</li> </ul>	<ul style="list-style-type: none"> <li>CPM1A-20EDR1</li> <li>● Input points: 12, DC input</li> <li>● Output points: 8, RY output</li> </ul>	<ul style="list-style-type: none"> <li>CPM1A-20EDT</li> <li>● Input points: 12, DC input</li> <li>● Output points: 8, TR output (Sink)</li> </ul>	<ul style="list-style-type: none"> <li>CPM1A-20EDT1</li> <li>● Input points: 12, DC input</li> <li>● Output points: 8, TR output (Source)</li> </ul>
--	--	---	--	---	---	--

### Temperature Sensor Units

- CPM1A-TS001
- Thermocouple inputs: 2
- CPM1A-TS002
- Thermocouple inputs: 4
- CPM1A-TS101
- Pt100 inputs: 2
- CPM1A-TS-101-DA
- Pt100 inputs: 2, Analog outputs: 1
- CPM1A-TS102
- Pt100 inputs: 4

### Analog I/O Units

- CPM1A-MAD01 (Resolution: 256)
- CPM1A-MAD11 (Resolution: 6,000)
- 2 inputs + 1 output
- CPM1A-AD041 (4 inputs)
- CPM1A-DA041 (4 outputs)

### DeviceNet

- CPM1A-DRT21
- I/O Link inputs: 32
- I/O Link outputs: 32

### PROFIBUS-DP

- PROFIBUS-DP I/O Link Unit
- CPM1A-PRT21
- I/O Link inputs: 16
- I/O Link outputs: 16

### CompoBus/S

- CompoBus/S I/O Unit
- CPM1A-SRT21
- I/O Link inputs: 8
- I/O Link outputs: 8

Space-saving Integration for Compact machines and Small-scale Control cabinets



- **Ultracompact Size**  
Ten-I/O-point AC models measure only 90 mm x 66 mm x 70 mm (H x W x D), and contain all basic PLC functions.
- **A Wide Variety of Models Handling from 10 to 100 I/O Points**  
By combining CPU Units having from 10 to 40 I/O points with 20-I/O-point Expansion I/O Units, CPM1A PLCs can be configured for 10 to 100 I/O points.
- **Programming by Programmable Terminal**  
Use of the optional Communications Adapter (RS-232C or RS-422 conversion) enables fast Host Link or NT Link communications with an OMRON Programmable Terminal. This makes it possible to program the CPM1A on the PT screen, greatly simplifying maintenance tasks.
- **High-speed Processing**  
Processing is fast, e.g., 0.7- $\mu$ s AND LD / OR LD and 16.3- $\mu$ s MOV instructions, allowing high-speed execution of even lengthy programs. Integrated interrupt and pulse catch inputs also handle high-speed pulses that occur within one program cycle.
- **Versatile Functions in a Compact Body**  
A large program capacity and instruction list handle even complicated control tasks with ease.
  - User memory: 2,048 words
  - Data memory: 1,024 words
  - Timer/counter: 128 points
  - Basic instructions: 14 types
  - Application instructions: 79 types
  - Analog setting dials: 2 points (built-in)
- **Pulse Output**  
CPM1A CPU models with transistor outputs can output pulses with a maximum frequency of 2 kHz. Combining these models with a Stepping Motor Driver or Servo Driver enables easy positioning operation.

**Application Example**

Changing the speed of a stepping motor.

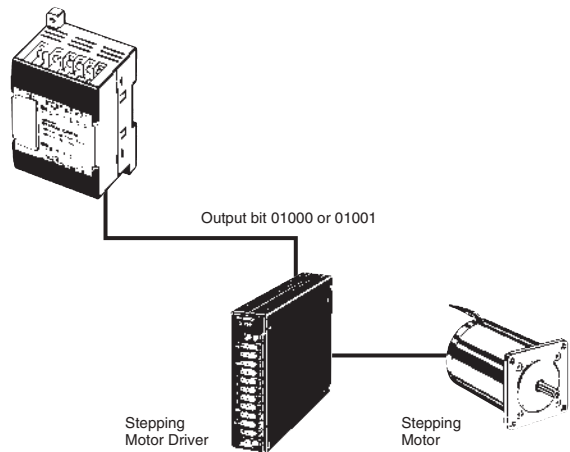

**Functions**

**Input Interrupts**

There are two input interrupts in the CPM1A 10-point I/O CPU and four in the 20-, 30-, and 40-point I/O CPUs. Input interrupts are available in two modes.

**10-point I/O CPU**

**20-, 30- and 40-point I/O CPU**

**Application Example:**

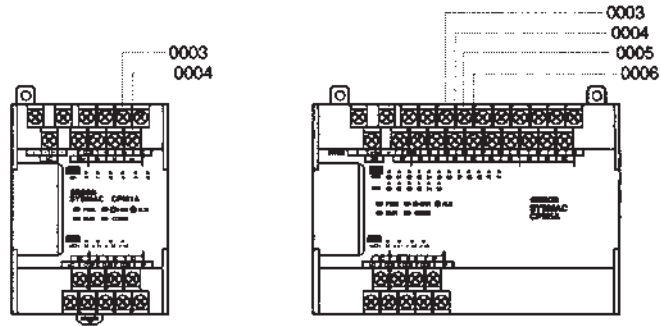

**Cutting Metal Sheets to Specified Lengths**

The proximity sensor detects the edge of a metal plate to operate the cutter. Metal sheets can be cut continuously to the specified lengths at a high speed.

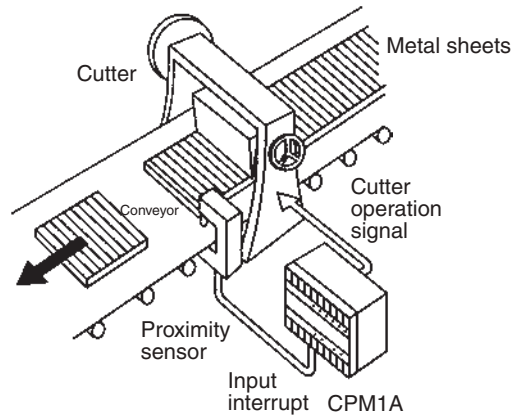

**Input Interrupt Mode**

If an input interrupt occurs, the regular program shuts down irrelevant of the cycle time, and the interrupt processing program is executed immediately.

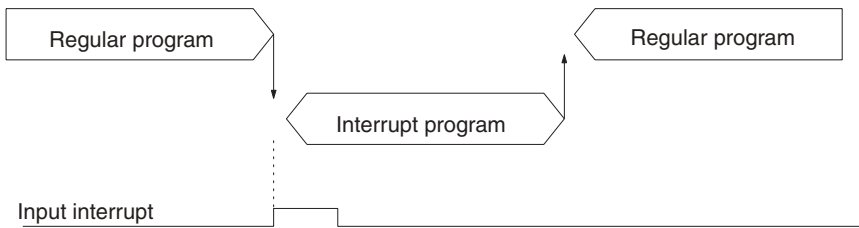

**Counter Mode**

When the number of external signals counted at high speed reaches a specified number of counts, the regular program shuts down, and the interrupt processing program is executed at fixed counts. The count can be set between 0 and 65535.

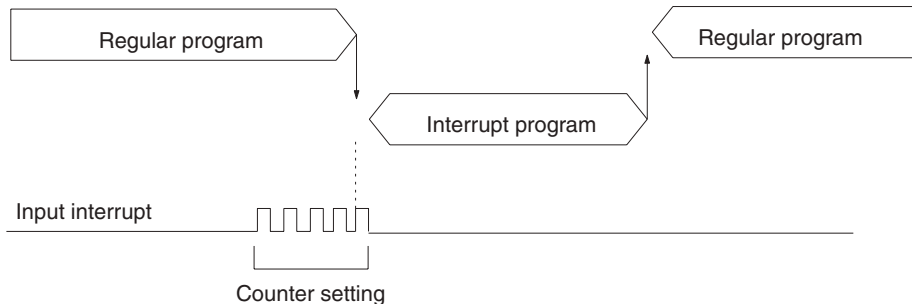

### Quick-response Inputs

There are two quick-response inputs for the CPM1A 10-point I/O CPU and four for the 20-, 30-, and 40-point I/O CPU (shared with the interrupt inputs). Since an internal buffer is provided, the quick-response input function can even detect signals modified within one cycle.

CPU	Input no.	Minimum input pulse width
10-point I/O CPU	00003 to 00004	0.2 ms
20-point, 30-point, 40-point I/O CPU	00003 to 00006	

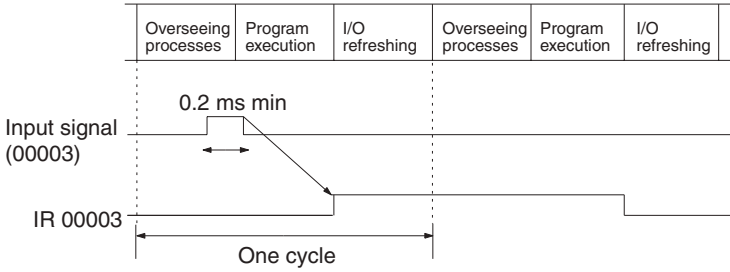

### Application Example:

#### Calculating the Number of Chips

The metal sensor counts the number of parts that have passed. Steady counting can be achieved even when the input-ON time is short.

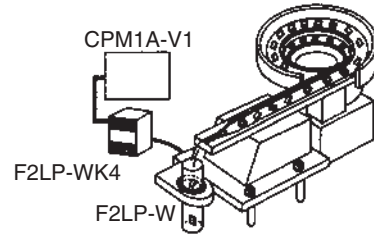

### High-speed Counter

The CPM1A has a high-speed counter function that can be used in the incrementing and up/down mode. Using this function together with the input interrupts enables zone comparison control or target value control irrelevant of the cycle time.

Item	Incrementing mode		Up/Down mode
Input no.	00000	Count input	A-phase input
	00001	---	B-phase input
	00002	Reset input	Z-phase input
Input method	Single-phase input		Phase-difference, 4 x inputs
Count frequency	5.0 kHz		2.5 kHz
Count range	0 to 65535		-32767 to 32767

**Note:** When using in the incrementing mode, the input 00001 can be used as an input contact.

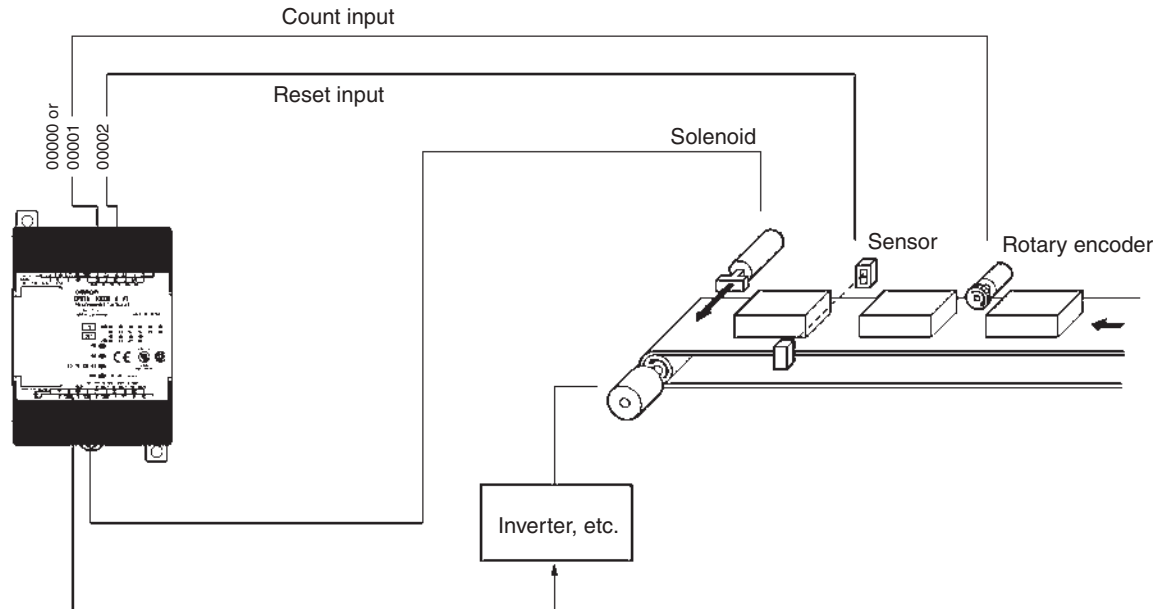

## Interval Timer Interrupts

The CPM1A has one interval timer. The interval timer shuts down the regular program irrelevant of the point in the cycle once the time is up, and immediately executes an interrupt processing program. Interval timers are used in the following two modes.

Item	One-shot mode	Scheduled interrupt mode
Operation	An interrupt is executed only once when the time is up.	Interrupts are executed repeatedly at fixed periods.
Setting time	0.5 ms to 319,968 ms (0.1-ms units)	

### Normal program

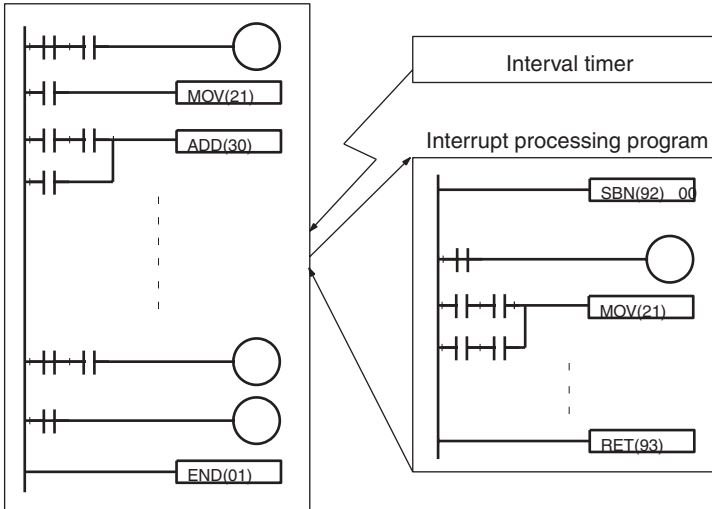

### Application example

#### Computing the Sheet Speed

The number of pulse inputs is computed in the interrupt mode at a fixed time to calculate the speed.

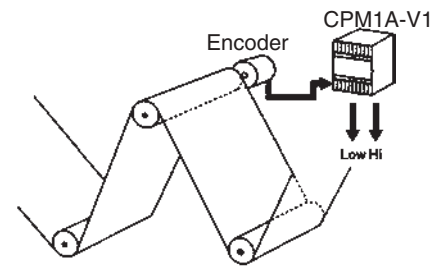

## Analog Setting

The CPM1A contains two analog setting controls that can be used for a broad range of analog timer and counter settings. Turning the setting control stores values of 0 to 200 (BCD data) in the SR area.

Analog setting	Storage area	Setting value (BCD)
Analog setting 0	SR 250	0000 to 0200
Analog setting 1	SR 251	

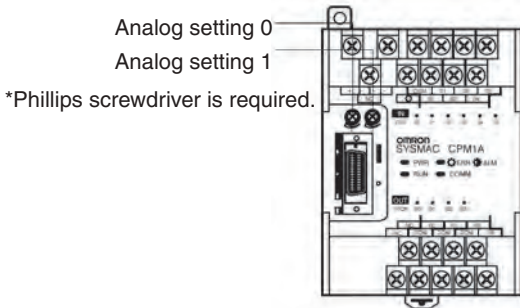

### Application Example:

#### Tact Operation Control of Conveyor Lines

A conveyor can be stopped temporarily as required for assembly processes. When the timer function and limit switches are used in a combination, conveyors can be stopped for a fixed time or can be run at a constant speed for a fixed distance. Fine adjustment of the stopping time can be easily done by using the analog setting controls.

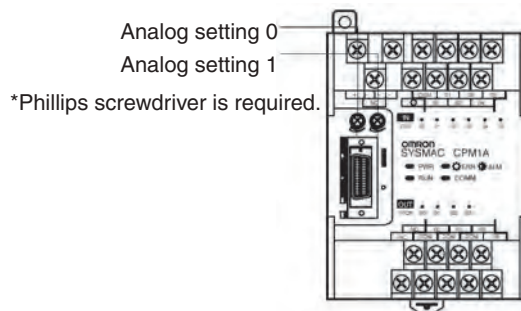

## Program Example

1. Analog timer for 0.0 to 20.0 seconds

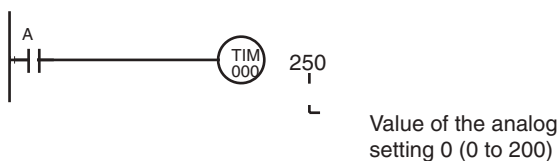

2. Analog timer for 0.0 to 60.0 seconds

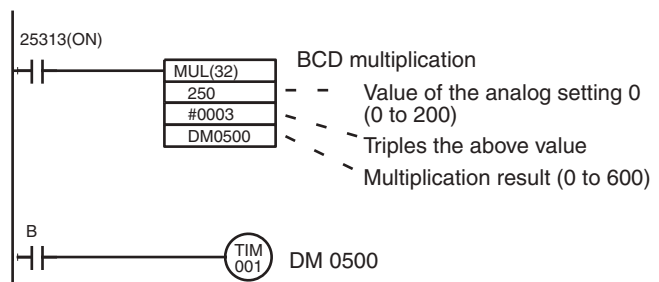

### Pulse Output Function

The CPM1A with transistor output has a function that is capable of outputting a pulse of up to 2 kHz.

When used in combination with a Stepping Driver or Servodriver, positioning can be easily performed.

### Application Example

Changing the speed of the Stepping Motor.

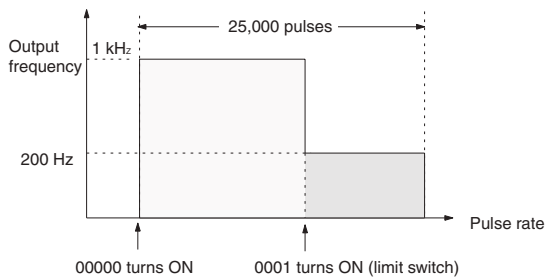
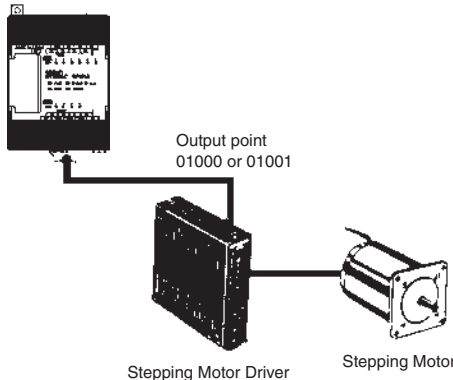

### Program Example

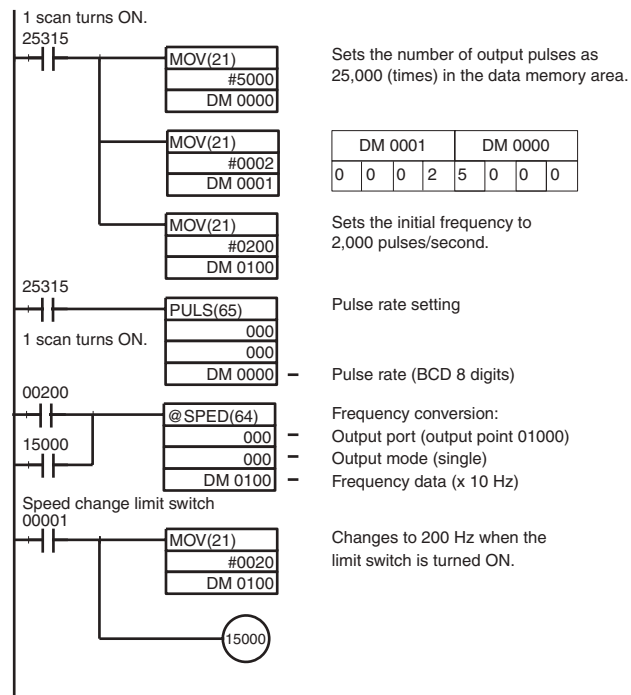

## Communications

### Host Link Communications

CPM1A host link communications consist of interactive procedures whereby the CPM1A returns a response to a command sent from the IBM PC/AT or compatible computer. These communications allow the IBM PC/AT or compatible computer to read and write in the CPM1A's I/O Areas and Data Memory Areas as well as in areas containing the status of various settings.

#### 1:1 Host Link Communications

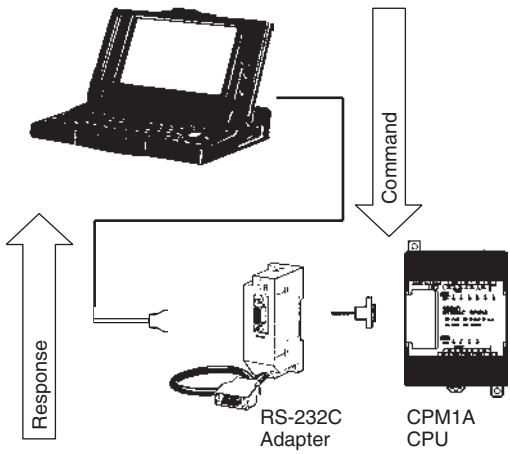

#### 1:n Host Link Communications

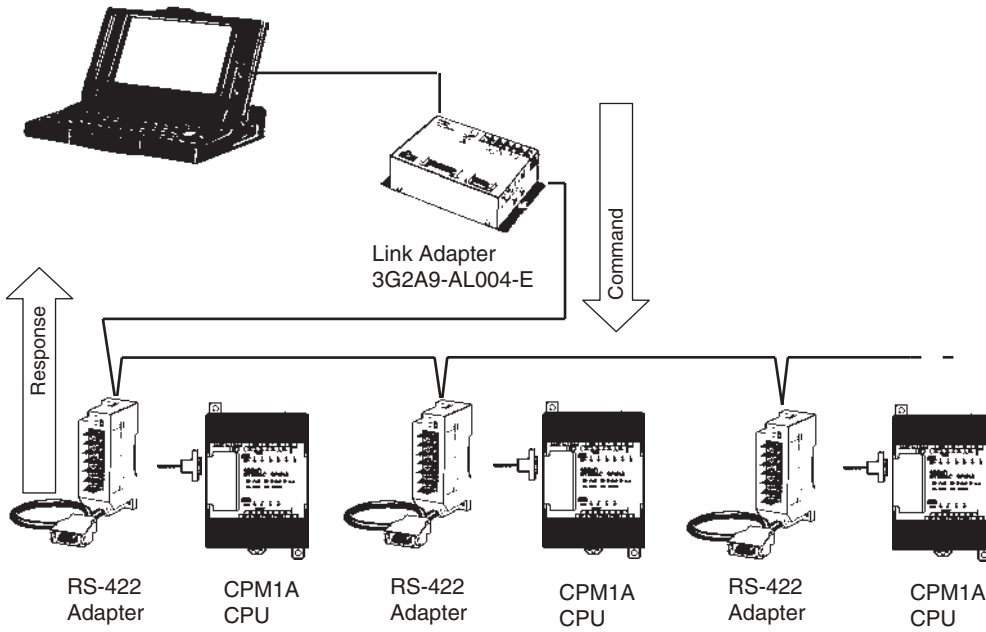

**1:1 Links**

With a 1:1 link, two CPM1As or a CPM1A and CQM1 or C200H□ are connected 1:1 with one side as the Master and the other as the Slave to provide an I/O link of a maximum of 256 points (LR 0000 to LR 1515).

**Example of a 1:1 Link between CPM1As**

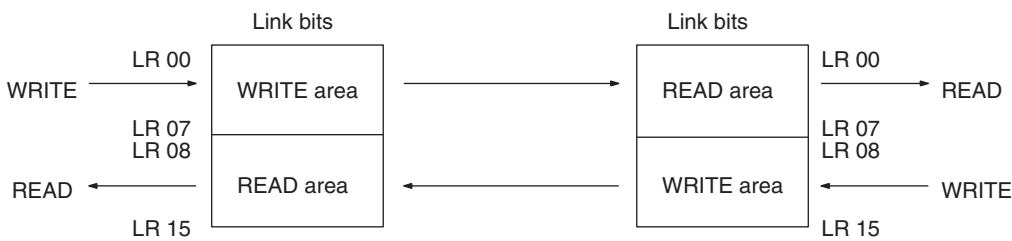
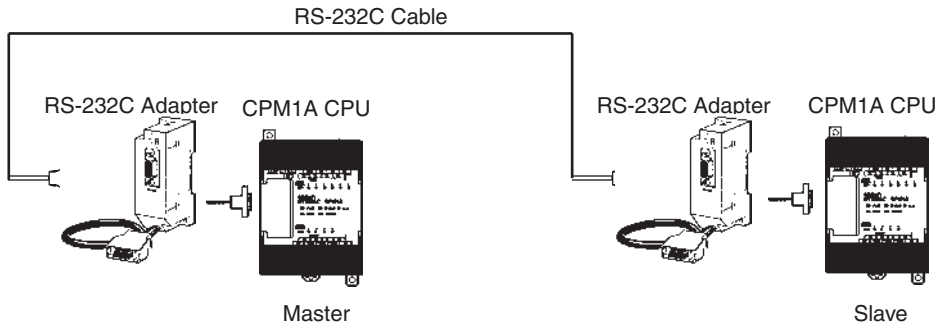

**Limitations of the CPM1A 1:1 Link**

CPM1A I/O links are limited to 16 words (LR 00 to LR 15). Therefore, use these 16 words (LR 00 to LR 15) on the CQM1 or C200H□ side when forming 1:1 links with a CQM1 or C200H□.

**NT Links**

High-speed communications can be achieved by providing a direct access through the use of the NT Link between the CPM1A and Programmable Terminal.

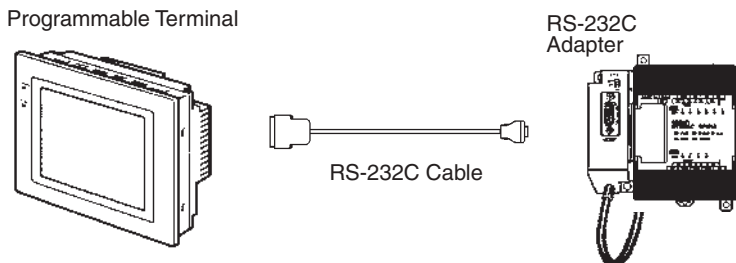



System Configuration

CPM1A Line-up

CPU with AC Power Supply • DC input • RY output / TR output  
 CPU with DC Power Supply • DC input • RY output / TR output

AC Power Supply Type DC Power Supply Type

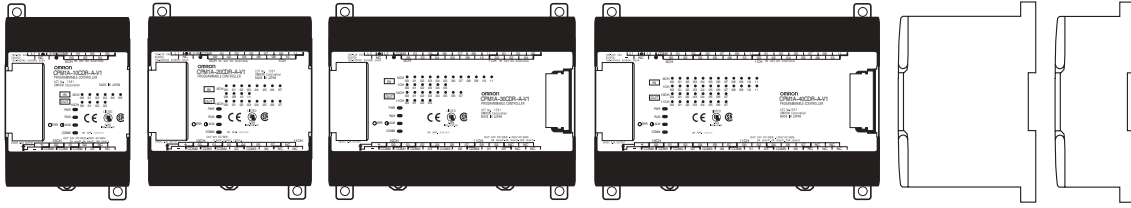

10 I/O points (Expansion not possible) 20 I/O points (Expansion not possible) 30 I/O points 40 I/O points

**Expansion I/O Unit**  
 • DC input  
 • RY output/TR output

**Expansion I/O Unit**  
 • DC input  
 • RY output/TR output

**DeviceNet I/O Link Unit**  
 CPM1A-DRT21

**PROFIBUS-DP I/O Link Unit**  
 CPM1A-PRT21

**CompoBus/S I/O Link Unit**  
 CPM1A-SRT21

**Analog I/O Unit**  
 CPM1A-MAD01  
 -MAD11  
 -AD041  
 -DA041

**Temperature Sensor Units**  
 CPM1A- TS001  
 TS002  
 TS101  
 TS101-DA  
 TS102

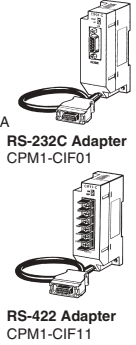
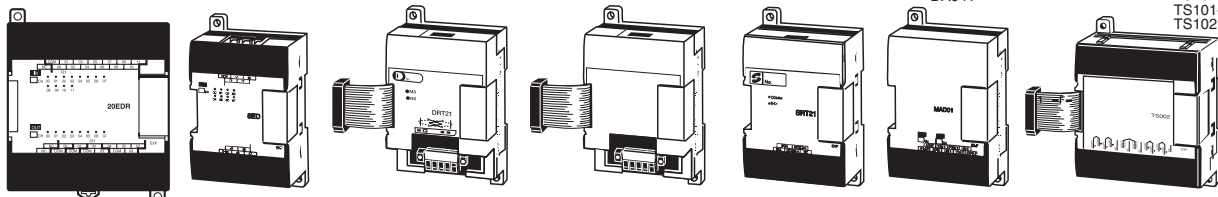

CPM1A System Configuration

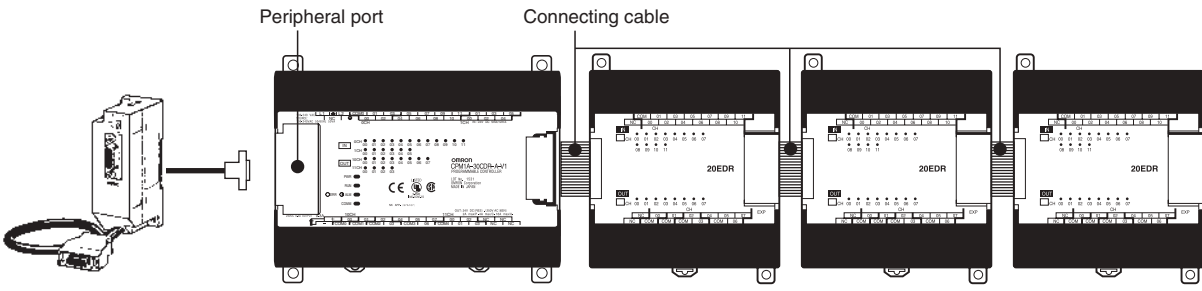

Both AC and DC power supplies. 30-point CPU and 40-point CPU only. May be expanded up to a maximum of 3 Units.

External Dimensions

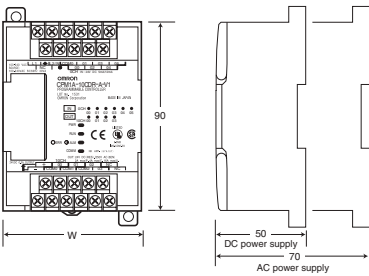

CPM1-CIF01

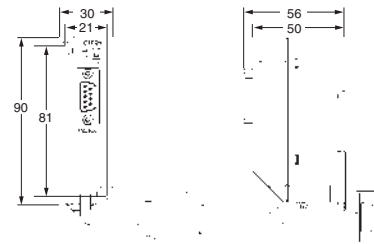

CPM1-CIF11

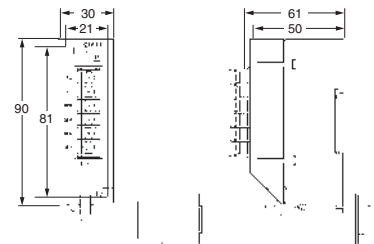

Model	W (mm)
CPM1A-10CD□-A-V1	66
CPM1A-10CD□-D-V1	66
CPM1A-20CD□-A-V1	86
CPM1A-20CD□-D-V1	86
CPM1A-30CD□-A-V1	130
CPM1A-30CD□-D-V1	130
CPM1A-40CD□-A-V1	150
CPM1A-40CD□-D-V1	150
CPM1A-20ED□	86 (depth: 50 mm)
CPM1A-8E□/SRT21	66 (depth: 50 mm)
CPM1A-MAD01/TS101-DA	66 (depth: 50 mm)
CPM1A-TS□□/MAD11	86 (depth: 50 mm)
CPM1A-DRT21/PRT21	66 (depth: 50 mm)
CPM1A-AD041/DA041	86 (depth: 50 mm)

### CPM1A System Configuration Example

A maximum of three Expansion I/O Units can be connected to the CPU Unit. Note that each 4-Channel Analog I/O Unit is counted as two Expansion Units (Group 2 Units, see Table 2).

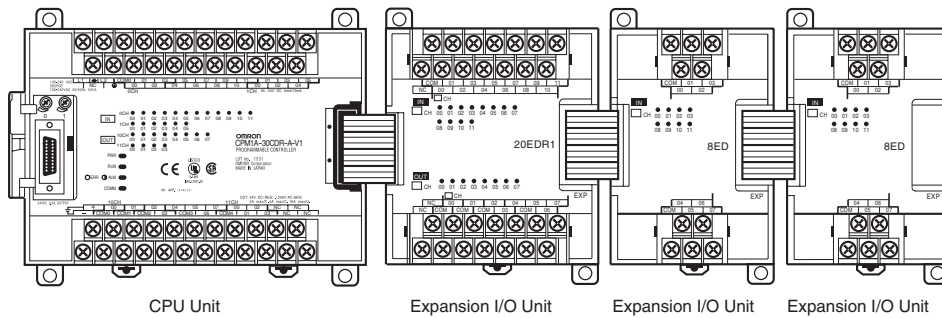

### Connection Groups for Expansion Units

Group 1 (G1)	Group 2 (G2)
Expansion I/O Units, Analog I/O Unit, CompoBus/S I/O Link Unit PROFIBUS-DP I/O Link Unit DeviceNet I/O Link Unit CPM1A-TS001/101(-DA)	CPM1A-TS002/102 CPM1A-AD041/DA041

In addition to the CPU Unit, Expansion Units from the groups indicated in the above table can be combined as shown below.

### Possible Expansion Unit Combinations

Expansion Unit 1	Expansion Unit 2	Expansion Unit 3
G1	G1	G1
G2	G1	---

- Note:**
- Expansion Units 1, 2, and 3 can be mounted in any order.
  - Only one Expansion Unit can be mounted if an NT-AL001 is connected to the RS-232C port.

### DC Power Supply-type CPM1A Power Consumption

Use the list below for calculating CPM1A power capacity. The CPM2C-PA201 AC Power Supply Unit provides 15 watts of power, so the remainder of the PLC power can be used as service power for sensors or other components.

CPM1A CPU Unit	Power Consumption (W)	Expandability
CPM1A-10CDR-D-V1	3.5	Not possible
CPM1A-20CDR-D-V1	4.5	Not possible
CPM1A-30CDR-D-V1	5.5	
CPM1A-40CDR-D-V1	6.5	
CPM1A-10CDT/T1-D-V1	3	Not possible
CPM1A-20CDT/T1-D-V1	3.5	Not possible
CPM1A-30CDT/T1-D-V1	4	
CPM1A-40CDT/T1-D-V1	4.5	

Add the following power consumption when using Expansion Units.

CPM1A CPU Unit	Power Consumption (W)
CPM1A-20EDR1	2.5
CPM1A-20EDT/T1	1.5
CPM1A-8ED	1
CPM1A-8ER	2
CPM1A-8ET/T1	1
CPM1A-SRT21/DRT21/PRT21	1
CPM1A-MAD01/MAD11	3.5
CPM1A-TS001/TS101(-DA)	3
CPM1A-TS002/TS102	3
CPM1A-AD041	3
CPM1A-DA041	3.3

The power consumption for the CPU Unit includes that of the Programming Console, RS-232C Adaptor, etc.

Specifications

General Specifications

Item		10-point I/O	20-point I/O	30-point I/O	40-point I/O
Power supply vol tage/fre- quency	AC power supply	100 to 240 V AC, 50/60 Hz			
	DC power supply	24 V DC			
Operating voltage range	AC power supply	85 to 264 V AC			
	DC power supply	20.4 to 26.4 V DC			
Power consumption	AC power supply	30 V AC max.		60 V AC max.	
	DC power supply	(See below.)			
Inrush current		30 A max.		60 A max.	
External power supply ( AC only)	Power supply voltage	24 V DC			
	Power supply output ca- pacity	200 mA		300 mA	
Insulation resistance		20 MΩ min. at 500 V DC between the AC terminals and the protective earth terminal.			
Dielectric strength		2,300 V AC at 50/60 Hz for one minute with a leakage current of 10 mA max. between all the external AC terminals and the protective earth terminal.			
Noise resistance		Conforms to IEC61000-4-4, 2 kV (power lines)			
Vibration resistance		10 to 57 Hz with an amplitude of 0.075 mm, and 57 to 150 Hz with an acceleration of 9.8 m/s <sup>2</sup> in the X, Y, and Z directions for 80 minutes each (i.e. swept for 8 minutes, 10 times).			
Shock resistance		147 m/s <sup>2</sup> in the X, Y and Z directions 3 times each.			
Ambient temperature (operating)		0° to 55° C			
Ambient humidity (operating)		10% to 90% (no condensation)			
Ambient environment (operating)		With no corrosive gas			
Ambient temperature (storage)		-20° to 75° C			
Terminal screw size		M3			
Power supply holding time		10 ms min. for AC models, and 2 ms min. for DC models			
Weight		AC model: 400 g max.	AC model: 500 g max.	AC model: 600 g max.	AC model: 700 g max.
		DC model: 300 g max.	DC model: 400 g max.	DC model: 500 g max.	DC model: 600 g max.

**Note:** The specifications of the Expansion I/O Unit are the same as for the CPU except that the power is supplied from the CPU and the weight is 300 g.

**Performance Specifications**

Item		10-point I/O	20-point I/O	30-point I/O	40-point I/O
Control method		Stored program method			
I/O control method		Combination of the cyclic scan and immediate refresh processing methods.			
Programming language		Ladder diagram			
Instruction word		1 step per instruction, 1 to 5 words per instruction			
Types of instructions	Basic instructions	14 types			
	Special instructions	79 types, 139 instructions			
Instruction execution time	Basic instructions	0.72 to 16.2 μs			
	Special instructions	MOV instruction = 16.3 μs			
Program capacity		2,048 words			
Maximum I/O points	CPU only	10 points (6 input/4 output points)	20 points (12 input/8 output points)	30 points (18 input/12 output points)	40 points (24 input/16 output points)
	With Expansion I/O Unit	---	---	90 points (54 input/36 output points)	100 points (60 input/40 output points)
Input bits		00000 to 00915 (Words 0 to 9)			
Output bits		01000 to 01915 (Words 10 to 19)			
Work bits (IR Area)		512: IR 20000 to IR 23115 (IR 200 to IR 231)			
System bits (SR Area)		384: SR 23200 to SR 25515 (SR 232 to SR 255)			
Temporary bits (TR Area)		8: TR 0 to TR 7			
Holding bits (HR Area)		320: HR 0000 to HR 1915 (HR 00 to HR 19)			
Auxiliary bits (AR Area)		256: AR 0000 to AR 1515 (AR 00 to AR 15)			
Link bits (LR Area)		256: LR 0000 to LR 1515 (LR 00 to LR 15)			
Timers/Counters		128:TIM/CNT 000 to 127 100-ms timer: TIM 000 to TIM 127 10-ms timer: TIM 000 to TIM 127 Decremental counter, reversible counter			
Data memory	Read/Write	1,024 words (DM 0000 to DM 1023)			
	Read only	512 words (DM 6144 to DM 6655)			
Interrupt processing: External interrupt		2 points (Response time of 0.3 ms max.)	4 points (Response time of 0.3 ms max.)		
Memory protection		Maintains the contents of the HR, AR, Counter and Data Memory Areas.			
Memory backup		Flash memory:User program, data memory (Read only) (Non-battery powered storage) Super capacitor:Data memory (Read/Write), holding bits, auxiliary memory bits, counter (20-day storage at an ambient temperature of 25° C)			
Self-diagnostic function		CPU error (watchdog timer), memory errors, I/O bus errors			
Program check		No END instruction, programming errors (constantly checked during operation)			
Pulse output		1 point: 2 kHz			
High-speed counter		1 point:Single phase at 5 kHz or two-phase at 2.5 kHz (linear counting method) Incremental mode: 0 to 65535 (16-bit) Decremental mode:–32767 to 32767 (16-bit) 1 point:Single phase at 5 kHz or two-phase at 2.5 kHz (linear counting method) Incremental mode: 0 to 65535 (16-bit) Decremental mode:–32767 to 32767 (16-bit)			
Quick-response inputs		Together with the external interrupt input (minimum pulse width of 0.2 ms)			
Input time constant		Can be set at 1 ms, 2 ms, 4 ms, 8 ms, 16 ms, 32 ms, 64 ms, or 128 ms.			
Analog settings		2 points: (0 to 200)			

**Note:** Bits that are not used for the I/O bits can be used as work bits.

## I/O Specifications

### Input Circuit

#### CPU

Item	Specifications	Circuit
Input voltage	24 V DC +10%/–15%	<p><b>Note:</b> The polarity of the input power supply can be either positive or negative. Resistance values in parentheses are for inputs IN00000 to IN00002.</p>
Input impedance	IN00000 to IN00002: 2 kΩ Others: 4.7 kΩ	
Input current (typical)	IN00000 to IN00002: 12 mA Others: 5 mA	
ON voltage	14.4 V DC min.	
OFF voltage	5.0 V DC max.	
ON delay (see note 1)	1 to 128 ms max. (default: 8 ms) (see note 1)	
OFF delay (see note 1)	1 to 128 ms max. (default: 8 ms) (see note 1)	

- Note:** 1. The actual ON/OFF delay includes a digital filter with a time constant of 1, 2, 4, 8, 16, 32, 64, or 128 ms (default: 8 ms).  
2. The delays for IN00000 to IN00002 are as follows when used for the high-speed counter.

Input	Increment mode	Differential phase mode
IN00000 (A-phase)	5 kHz	2.5 kHz
IN00001 (B-phase)	Normal input	
IN00002 (Z-phase)	ON: 100 μs max. OFF: 500 μs max.	

3. The delays for IN00003 to IN00006 are as follows when used for the high-speed counter.

Delay	0.3 ms max. (From the time of input ON until the interrupt subroutine is executed.) <sup>*1</sup>

<sup>\*1</sup> For detailed specifications of expansion I/O units, see page 68.

### Expansion I/O Unit

Item	Specifications	Circuit
Input voltage	24 V DC +10%/–15%	<p><b>Note:</b> The polarity of the input power supply can be either positive or negative.</p>
Input impedance	4.7 kΩ	
Input current (typical)	5 mA	
ON voltage	14.4 V DC min.	
OFF voltage	5.0 V DC max.	
ON delay (see note 1)	1 to 128 ms max. (default: 8 ms) (see note 1)	
OFF delay (see note 1)	1 to 128 ms max. (default: 8 ms) (see note 1)	

- Note:** The actual ON/OFF delay includes an input constant of 1, 2, 4, 8, 16, 32, 64, or 128 ms (default: 8 ms).

### Output Circuit

#### CPU and Expansion I/O Unit Relay Output

Item	Specifications	Circuit		
Maximum switching capacity	250 V AC/2 A (cosφ =1) 24 V DC/2 A (4 A/common)	<p>Maximum 250 VAC: 2 A 24 VDC: 2A</p>		
Minimum switching capacity	5 V DC, 10 mA			
Relay service life	Electrical		Resistive load	150,000 times (at 24 V DC)
			Inductive load	100,000 times (at 200 V AC, cosφ =0.4)
	Mechanical		20 million times	
ON delay	15 ms max.			
OFF delay	15 ms max.			

**Transistor Output (Sink Type/Source Type) (CPU/Expansion I/O Unit)**

Item	Specifications	Circuit
Maximum switching capacity	24 V DC +10%/–15%, 300 mA (see note 1)	
Leakage current	0.1 mA max.	
Residual voltage	1.5 V max.	
ON delay	0.1 ms max.	
OFF delay	1 ms max. (see note 2)	

**Note: 1.** The maximum switching capacity of the CPM1A with transistor outputs (sink type and source type) is limited to the currents shown in the following table for the common and for the Unit.

Item	10CDT-V1/ 10CDT1-A-V1/D-V1	20CDT-D-V1/ 20CDT1-A-V1/D-V1	30CDT-D-V1/ 30CDT1-A-V1/D-V1	40CDT-D-V1/ 40CDT1-A-V1/D-V1	20EDT/20EDT1	CPM1A-8ET/8ET1
Max. switching capacity	0.9 A/Unit	0.9 A/common 1.8 A/Unit	0.9 A/common 2.7 A/Unit	0.9 A/common 3.6 A/Unit	0.9 A/common 1.8 A/Unit	

**2.** When using the pulse output function of the CPM1A with transistor outputs (sink type and source type):  
The output current must be between 100 to 200 mA when using the output 01000 or 01001 as a pulse output with the maximum frequency of 2 kHz.  
The off-delay of outputs 01000 and 01001 will vary depending on the output current.

Load current	OFF delay
100 to 200 mA	0.2 ms max.
0 to 300 mA except for the above range	0.5 ms max.

**Analog I/O Unit**

Item	CPM1A-MAD01		CPM1A-MAD11		CPM1A-AD041		CPM1A-DA041		
	Voltage I/O	Current I/O	Voltage I/O	Current I/O	Voltage I/O	Current I/O	Voltage I/O	Current I/O	
Analog inputs	Number of inputs	2		2 (allocated 2 words)		4 (allocated 4 words in + 2 words out)			
	Input signal ranges	0 to 10 V or 1 to 5 V	4 to 20 mA	0 to 5 V, 1 to 5 V, 0 to 10 V, –10 to 10 V	0 to 20 mA, 4 to 20 mA	0 to 5 V, 1 to 5 V, 0 to 10 V, –10 to 10 V	0 to 20 mA, 4 to 20 mA		
	Maximum rated input	±15 V	±30 mA	±15 V	±30 mA	±15 V	±30 mA		
	External input impedance	1 MΩ min.	250 Ω rated	1 MΩ min.	250 Ω	1 MΩ min.	250 Ω		
	Resolution	1/256		1/6,000 (full scale)		1/6,000 (full scale)			
	Overall precision	1.0% of full scale		25°C:±0.3% of full scale 0 to 55°C:±0.6% of full scale	25°C:±0.4% of full scale 0 to 55°C:±0.8% of full scale	25°C:±0.3% of full scale 0 to 55°C:±0.6% of full scale	25°C:±0.4% of full scale 0 to 55°C:±0.8% of full scale		
	Converted A/D data	8-bit binary data Full scale = 0000 to 00FF Hex		Binary data (4-digit hexadecimal) –10 to 10 V: F448 to 0BB8 Hex full scale Other:0000 to 1770 Hex full scale		Binary data (4-digit hexadecimal) –10 to 10 V: F448 to 0BB8 Hex full scale Other:0000 to 1770 Hex full scale			
	Averaging	---		Supported (set for each input with DIP switch)		Supported (set for each input with DIP switch)			
Disconnection detection	---		Supported		Supported				
Analog output (See note 1.)	Number of outputs	1		1 (1 word allocated )				4 (4 words allocated)	
	Output signal ranges	0 to 10 V or –10 to 10 V	4 to 20 mA	1 to 5 V, 0 to 10 V, –10 to 10 V	0 to 20 mA, 4 to 20 mA			1 to 5 V, 0 to 10 V, –10 to 10 V	0 to 20 mA, 4 to 20 mA
	External output allowed load resistance	2 kΩ min.	350 Ω max.	1 kΩ min.	600 Ω max.			1 kΩ min.	600 Ω max.
	External output impedance	---		0.5 Ω max.	---			0.5 Ω max.	---
	Resolution	1/256 (1/512 when the output signal range is –10 to 10 V.)		1/6,000 (full scale)				1/6,000 (full scale)	
	Overall precision	1.0% of full scale		25°C:±0.4% of full scale 0 to 55°C:±0.8% of full scale				25°C:±0.4% of full scale 0 to 55°C:±0.8% of full scale	
	D/A data setting	8-bit plus sign binary data –10 to 10 V output range: Full scale = 80FF to 00FF Hex 4 to 20 mA output range: Full scale = 0000 to 00FF Hex		Binary data (hexadecimal, 4-digit) –10 to 10 V output range: Full scale = F448 to 0BB8 Hex Other output ranges: Full scale = 0000 to 1770 Hex				Binary data (hexadecimal, 4-digit) –10 to 10 V output range: Full scale = F448 to 0BB8 Hex Other output ranges: Full scale = 0000 to 1770 Hex	
Conversion time	10 ms/Unit max. (See note 2.)		2 ms/point		2 ms/point		2 ms/point		
Isolation method	Photocoupler isolation between I/O terminals and PC (There is no isolation between the analog I/O signals.)		Photocoupler isolation between analog I/O and internal circuits. (Individual analog I/O signals are not isolated.)		Photocoupler isolation between analog I/O and internal circuits. (Individual analog I/O signals are not isolated.)		Photocoupler isolation between analog I/O and internal circuits. (Individual analog I/O signals are not isolated.)		

**Note: 1.** The voltage output and current output can be used at the same time, but the total output current cannot exceed 21 mA.  
**2.** The conversion time is the total time for 2 analog inputs and 1 analog output.

### Temperature Sensor Units

By mounting a Temperature Sensor Unit (CPM1A-TS001/TS002/TS101/TS102) to the PLC, input can be obtained from a thermocouple or platinum resistance thermometer, and temperature measurements can be converted to binary data (4-digit hexadecimal) and cyclically updated in the input area of the CPU Unit.

#### Specifications

Item	Specifications	
Model	CPM1A-TS001/002	CPM1A-TS101/102
Number of inputs	2 (TS001), 4 (TS002)	2 (TS101), 4 (TS102)
Input types	Thermocouple K, J switchable (Note: Same type for all input points.)	Pt100, JPt100 switchable (Note: Same type for all input points.)
Indication accuracy	The larger of $\pm 0.5\%$ of the indicated value and $\pm 2^\circ\text{C} \pm 1$ digit max.	[The larger of $\pm 0.5\%$ of the indicated value and $\pm 1^\circ\text{C} \pm 1$ digit max.
Conversion time	250 ms/2 points (TS001, TS101); 250 ms/4 points (TS002, TS102)	
Converted temperature data	Binary (4-digit hexadecimal)	
Isolation method	Photocoupler isolation between the temperature input signals.	

**Note:** The indication accuracy when using a K-type thermocouple for temperatures less than  $-100^\circ\text{C}$  is  $\pm 4^\circ\text{C} \pm 1$  digit max.

#### Input Temperature Ranges for CPM1A-TS001/002

The rotary switch can be used to make of the following range and input type settings for CPM1A-TS001/002 models.

Input type	Range ( $^\circ\text{C}$ )	Range ( $^\circ\text{F}$ )
K	-200 to 1300	-300 to 2300
	0.0 to 500.0	0.0 to 900.0
J	-100 to 850	-100 to 1500
	0.0 to 400.0	0.0 to 750.0

#### Input Temperature Ranges for CPM1A-TS101/102

The rotary switch can be used to make of the following range and input type settings for CPM1A-TS101/102 models.

Input type	Range ( $^\circ\text{C}$ )	Range ( $^\circ\text{F}$ )
Pt100	-200.0 to 650.0	-300 to 1200.0
JPt100	-200.0 to 650.0	-300 to 1200.0

#### Specifications CPM1A-TS101-DA

Item	Specifications
Model	CPM1A-TS101-DA
Number of inputs	2
Input types	Pt100
Temperature range	$-40$ to $250^\circ\text{C}$
Converted temperature data	16-bit, 2's complement, $0.1^\circ\text{C}$ resolution
Indication accuracy	1.0% of full scale max.
Number of outputs	1
Output type	0 to 10 V, -10 to 10 V, 4 to 20 mA
Load resistance	2 k $\Omega$ min. (voltage output), 500 $\Omega$ max. (current output)
Output resolution	8 bit + sign (1/256, 1/512 for -10 to 10 V)
Output accuracy	1.0% of full scale max.
Conversion time	60 ms (all channels)
Isolation method	Photocoupler isolation between I/O signals and PLC

#### DeviceNet I/O Link Unit - CPM1A-DRT21

By connecting the DeviceNet I/O Link Unit (CPM1A-DRT21), the CPM1A can function as the slave of a DeviceNet Master Unit. In this configuration, 32 input- and 32 output bits are exchanged with the Master Unit.

#### Specifications

Item	Specification
Master/slave	DeviceNet Slave
Number of I/O points allocated to Master	Input: 32 points / Output: 32 points
Number of words allocated from CPM1A's I/O memory	Input: 2 words / Output: 2 words (Allocated in the same way as other Expansion Units).
Node address setting method	Set using DIP switch.

#### PROFIBUS-DP I/O Link Unit - CPM1A-PRT21

By connecting the PROFIBUS-DP I/O Link Unit (CPM1A-PRT21), the CPM1A can function as the slave of any PROFIBUS-DP Master Unit. In this configuration, 16 input- and 16 output bits are exchanged with the Master unit.

#### Specifications

Item	Specification
Master/slave	PROFIBUS-DP slave (OC_0658.GSD)
Number of I/O points allocated to Master	Input: 16 points / Output: 16 points (Intel/Motorola format selectable by DIP switch)
Number of words allocated from CPM1A's I/O memory	Input: 1 word / Output: 1 word (Allocated in the same way as other Expansion Units).
Node address setting method	0-99 using 2 rotary switches

CompoBus/S I/O Link Unit - CPM1A-SRT21

Specifications

Item	Specification
Master/Slave	CompoBus/S Slave
Number of I/O bits	8 input bits, 8 output bits
Number of words occupied in CPM2A I/O memory	1 input word, 1 output word (Allocated in the same way as other Expansion Units).
Node number setting	Set using the DIP switch. (Set before turning ON power for the CPU Unit.)

Communications Adapter Specifications CPM1-CIF01/CIF11

RS-232C Adapter and RS-422 Adapter

Item	Specifications	
	CPM1-CIF01	CPM1-CIF11
Functions	Level conversion between the CMOS level (CPU side) and the RS-232C level (peripheral device side)	Level conversion between the CMOS level (CPU side) and the RS-422 level (peripheral device side)
Isolation (all in this line)	The RS-232C (peripheral device side) is insulated by a DC/DC converter and photocoupler.	The RS-422 (peripheral device side) is insulated by a DC/DC converter and photocoupler.
Power supply	Power is supplied by the CPU.	
Weight	200 g max.	

Expansion Memory Unit CPM1A-EMU01-V1

The CPM1A-EMU01-V1 offers simple onsite transfer of user programs and data memory.

Item	Specifications
Supported PLCs	CPM1, CPM1A, CPM2A, CPM2C, SRM1(-V2), CQM1, CQM1H
Read/write memory areas	User Program: 15.2 kWords max. Data memory: DM 6144 to DM 6655
Expansion instructions	18 instructions
EEPROM	256-Kbit EEPROM, ATMEL: AT28C256, OMRON: EEROM-JD
Current consumption	130 mA max.
Dimensions (not including cables or connectors)	57 x 92 x 38 mm (W x H x D)
Weight	200 g max. (not including EEPROM)

Specifications

CPM2C-PA201 AC Power Supply Unit

- The CPM2C-PA201 is a slim and compact AC Power Supply Unit of the same shape as the CPM2C's CPU Unit. It can be connected simply using the connecting cable (23 cm) provided. It can also be used for CPM1A and CPM2A CPU Units and as display power supply (wired by the user).

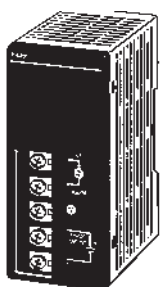

Service power supply for external devices such as sensors (24 V).

AC Power Supply Unit

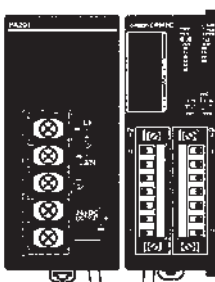

AC Power Supply Unit

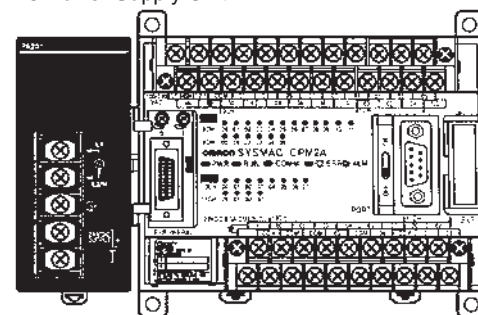

Attached connecting cable

Item	Specification		
Rated output	15 W		
Output voltage	24 V		
Output current	600 mA		
Efficiency	75% min. (at rated output)		
Input conditions	Rated voltage	100 to 240 V AC	
	Allowable voltage range	85 to 264 V AC	
	Frequency	47 to 63 Hz	
	Current	100 V	0.4 A
		200 V	0.2 A
	Leakage current	100 V	0.5 mA max. (at rated output)
		200 V	1 mA max. (at rated output)
	Inrush current	100 V	15 A max. (at 25° C cold start)
200 V		30 A max. (at 25° C cold start)	



Item	Specification	
Output characteristics	Output voltage accuracy	10%–15% (including input, load, and temperature fluctuations)
	Minimum output current	30 mA
	Ripple noise voltage	2% (p-p) max.
	Input fluctuation	0.75% max.
	Load fluctuation	4% max.
	Temperature fluctuation	0.05%/°C max.
	Startup time	300 ms max. (at input voltage of 100 V AC or 200 V AC and the rated output)
	Output hold time	10 ms (at input voltage of 100 V AC or 200 V AC and the rated output)
Overcurrent protection	Self-resetting, operates at 105% to 335% of the rated current, suspended and independent operation	
Overvoltage protection	None	
Ambient operating temperature	0° to 55° C	
Ambient storage temperature	–20° to 75° C (no condensation or icing)	
Ambient operating humidity	10% to 90% (no condensation)	
Dielectric strength	2,000 V for 1 min between all inputs and GR Leakage current: 10 mA 3,000 V for 1 min between all inputs and all outputs Leakage current: 10 mA 1,000 V for 1 min between all outputs and GR Leakage current: 10 mA	
Insulation resistance	100 MΩ min. at 500 V DC between all outputs and any input, and between all outputs and GR	
Vibration resistance	10 to 57 Hz, amplitude, 57 to 150 Hz, acceleration: 9.8 m/s <sup>2</sup> in X, Y, and Z directions for 80 minutes according (Time coefficient: 8 minutes × coefficient factor 10 = total time 80 min.)	
Shock resistance	147 m/s <sup>2</sup> 3 times each in X, Y, and Z directions	
Noise terminal voltage	FCC class A	
Weight	250 g max.	

Peripheral Devices

CPM1A CPU



IBM PC/AT or compatible



CX-One:  
Omron's integrated software for programming and configuration of all control system components, including PLCs, HMI, drives, temperature controllers and advanced sensors.

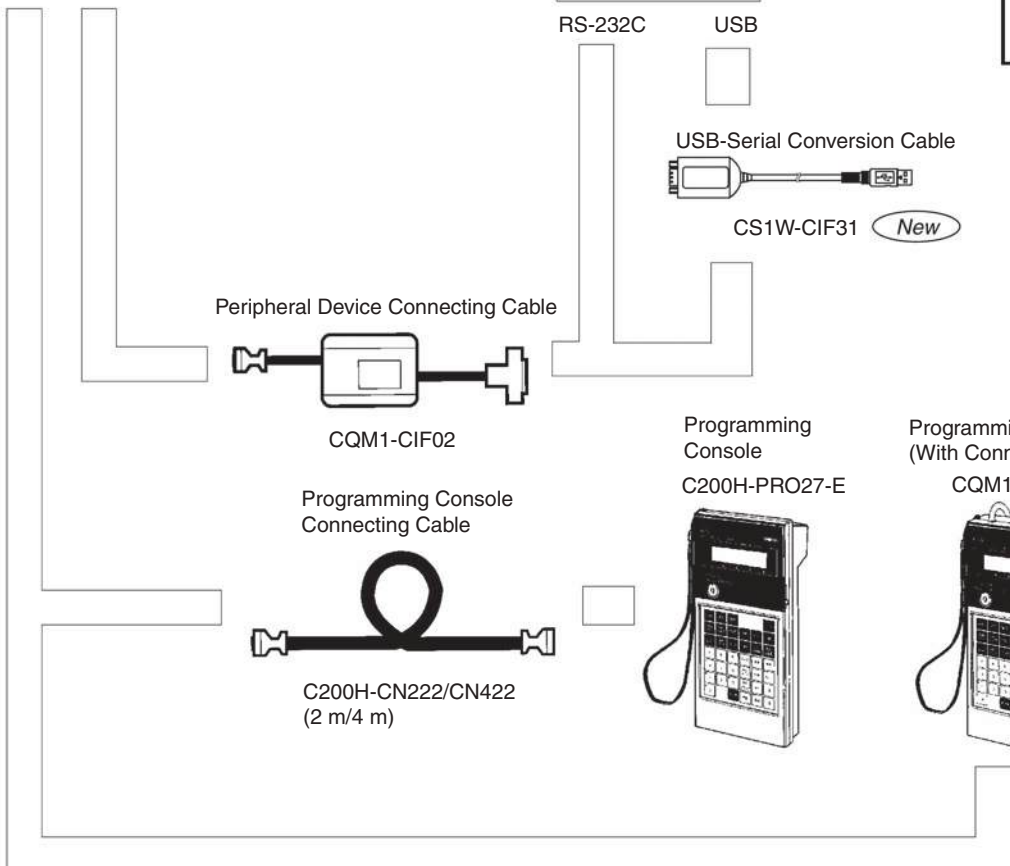
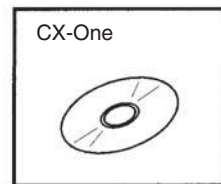

# CPM1A Ordering Information

## International Standards

The products shown in the attached tables are those that conform to the UL, CSA, cULus, cUL, NK, Lloyd's Register, and EC Directives as of September 2003.

(U: UL, C: CSA, UC: cULus, CU: cUL, N: NK, L: Lloyd, CE: EC Directives)

Please contact OMRON representative for application conditions.

## CPU Units

Name	Power supply	Output method	Input points	Output points	Model	Standards
10-point I/O	AC power supply	Relay output	6 points	4 points	CPM1A-10CDR-A-V1	U, C, N, L, CE
		Transistor output (sink type)			CPM1A-10CDT-A-V1	U, C, CE
		Transistor output (source type)			CPM1A-10CDT1-A-V1	
	DC power supply	Relay output			CPM1A-10CDR-D-V1	U, C, N, L, CE
		Transistor output (sink type)			CPM1A-10CDT-D-V1	U, C, CE, N
		Transistor output (source type)			CPM1A-10CDT1-D-V1	
20-point I/O	AC power supply	Relay output	12 points	8 points	CPM1A-20CDR-A-V1	U, C, N, L, CE
		Transistor output (sink type)			CPM1A-20CDT-A-V1	U, C, CE
		Transistor output (source type)			CPM1A-20CDT1-A-V1	
	DC power supply	Relay output			CPM1A-20CDR-D-V1	U, C, N, L, CE
		Transistor output (sink type)			CPM1A-20CDT-D-V1	U, C, CE, N
		Transistor output (source type)			CPM1A-20CDT1-D-V1	
30-point I/O	AC power supply	Relay output	18 points	12 points	CPM1A-30CDR-A-V1	U, C, N, L, CE
		Transistor output (sink type)			CPM1A-30CDT-A-V1	U, C, CE
		Transistor output (source type)			CPM1A-30CDT1-A-V1	
	DC power supply	Relay output			CPM1A-30CDR-D-V1	U, C, N, L, CE
		Transistor output (sink type)			CPM1A-30CDT-D-V1	U, C, CE, N
		Transistor output (source type)			CPM1A-30CDT1-D-V1	
40-point I/O	AC power supply	Relay output	24 points	16 points	CPM1A-40CDR-A-V1	U, C, N, L, CE
		Transistor output (sink type)			CPM1A-40CDT-A-V1	U, C, CE
		Transistor output (source type)			CPM1A-40CDT1-A-V1	
	DC power supply	Relay output			CPM1A-40CDR-D-V1	U, C, N, L, CE
		Transistor output (sink type)			CPM1A-40CDT-D-V1	U, C, CE, N
		Transistor output (source type)			CPM1A-40CDT1-D-V1	

## Expansion Units and Expansion I/O Units

Unit	Input/Output type	Inputs	Outputs	Model	Standards
Expansion I/O Units	Relay	24	16	CPM1A-40EDR	CE, N
	Transistor (sinking)			CPM1A-40EDT	CE, N
	Transistor (sourcing)			CPM1A-40EDT1	CE, N
	Relay	12	8	CPM1A-20EDR1	U, C, CE, N
	Transistor (sinking)			CPM1A-20EDT	U, C, CE, N
	Transistor (sourcing)			CPM1A-20EDT1	U, C, CE, N
	---	8	---	CPM1A-8ED	U, C, CE, N
	Relay	---	8	CPM1A-8ER	U, C, CE, N
	Transistor (sinking)			CPM1A-8ET	U, C, CE, N
Transistor (sourcing)	CPM1A-8ET1			U, C, L, CE, N	
Analog I/O Unit	Analog (resolution: 1/256)	2	1	CPM1A-MAD01	U, C, CE, N
	Analog (resolution: 1/6000)	2	1	CPM1A-MAD11	U, C, CE, N
	Analog (resolution: 1/6000)	4	---	CPM1A-AD041	U, C, CE
	Analog (resolution: 1/6000)	---	4	CPM1A-DA041	U, C, CE
DeviceNet I/O Link Unit	---	I/O Link of 32 input bits and 32 output bits		CPM1A-DRT21	U, C, CE, N
PROFIBUS-DP I/O Link Unit	---	I/O Link of 16 input bits and 16 output bits		CPM1A-PRT21	CE
CompoBus/S I/O Link Unit	---	I/O Link of 8 input bits and 8 output bits		CPM1A-SRT21	U, C, CE, N
Temperature Sensor Units	2 thermocouple inputs			CPM1A-TS001	U, C, CE, N
	4 thermocouple inputs			CPM1A-TS002	U, C, CE, N
	2 platinum resistance thermometer inputs			CPM1A-TS101	U, C, CE, N
	4 platinum resistance thermometer inputs			CPM1A-TS102	U, C, CE, N
	2 Platinum resistance thermometer inputs (-40 to 250 °C) and one output (-10 to 10V, 4 to 20 mA)			CPM1A-TS101-DA	U, C, L, CE

## RS-232C Adapter, RS-422 Adapter, Connecting Cable, Link Adapter

Name	Function	Model	Standards
RS-232C Adapter	Converts peripheral port levels.	CPM1-CIF01	N, L, CE
RS-422 Adapter		CPM1-CIF11	
Connecting Cable	3.3-m cable used to connect IBM PC/AT or compatible personal computers.	CQM1-CIF02	U, C, N, L, CE
Link Adapter	Converts RS-232C and RS-422 levels.	3G2A9-AL004-E	---

## Programming Consoles and Cables

Product	Model	Standards	
Programming Console (2-m cable attached)	CQM1-PRO01-E	U, C, N, CE	
Programming Console (Requires separate cable. See below.)	C200H-PRO27-E	U, C, N, CE	
Connecting Cable for C200H-PRO27-E	2-m cable	C200H-CN222	N
	4-m cable	C200H-CN422	---

## Support Software

Product	Functions	Model	Standards
CX-One	Omron's integrated software for programming and configuration of all control system components, including PLCs, HMI, drives, temperature controllers and advanced sensors.	CX-ONE-AL□□C-E <sup>*1</sup>	---

\*1 □□ = Number of licenses (01, 03, 10)

Product	Model	Standards
Expansion Memory Unit	CPM1-EMU01-V1	---
EEPROM (256 K)	EEPROM-JD	---

## Power Supply Unit

Unit	Input	Output	Model	Standards
Power Supply	100 to 240 V AC	24 V DC/600 mA	CPM2C-PA201	U, C, CE

# Terms and Conditions of Sale

1. **Offer; Acceptance.** These terms and conditions (these "Terms") are deemed part of all quotes, agreements, purchase orders, acknowledgments, price lists, catalogs, manuals, brochures and other documents, whether electronic or in writing, relating to the sale of products or services (collectively, the "Products") by Omron Electronics LLC and its subsidiary companies ("Omron"). Omron objects to any terms or conditions proposed in Buyer's purchase order or other documents which are inconsistent with, or in addition to, these Terms.
2. **Prices; Payment Terms.** All prices stated are current, subject to change without notice by Omron. Omron reserves the right to increase or decrease prices on any unshipped portions of outstanding orders. Payments for Products are due net 30 days unless otherwise stated in the invoice.
3. **Discounts.** Cash discounts, if any, will apply only on the net amount of invoices sent to Buyer after deducting transportation charges, taxes and duties, and will be allowed only if (i) the invoice is paid according to Omron's payment terms and (ii) Buyer has no past due amounts.
4. **Interest.** Omron, at its option, may charge Buyer 1-1/2% interest per month or the maximum legal rate, whichever is less, on any balance not paid within the stated terms.
5. **Orders.** Omron will accept no order less than \$200 net billing.
6. **Governmental Approvals.** Buyer shall be responsible for, and shall bear all costs involved in, obtaining any government approvals required for the importation or sale of the Products.
7. **Taxes.** All taxes, duties and other governmental charges (other than general real property and income taxes), including any interest or penalties thereon, imposed directly or indirectly on Omron or required to be collected directly or indirectly by Omron for the manufacture, production, sale, delivery, importation, consumption or use of the Products sold hereunder (including customs duties and sales, excise, use, turnover and license taxes) shall be charged to and remitted by Buyer to Omron.
8. **Financial.** If the financial position of Buyer at any time becomes unsatisfactory to Omron, Omron reserves the right to stop shipments or require satisfactory security or payment in advance. If Buyer fails to make payment or otherwise comply with these Terms or any related agreement, Omron may (without liability and in addition to other remedies) cancel any unshipped portion of Products sold hereunder and stop any Products in transit until Buyer pays all amounts, including amounts payable hereunder, whether or not then due, which are owing to it by Buyer. Buyer shall in any event remain liable for all unpaid accounts.
9. **Cancellation; Etc.** Orders are not subject to rescheduling or cancellation unless Buyer indemnifies Omron against all related costs or expenses.
10. **Force Majeure.** Omron shall not be liable for any delay or failure in delivery resulting from causes beyond its control, including earthquakes, fires, floods, strikes or other labor disputes, shortage of labor or materials, accidents to machinery, acts of sabotage, riots, delay in or lack of transportation or the requirements of any government authority.
11. **Shipping; Delivery.** Unless otherwise expressly agreed in writing by Omron:
  - a. Shipments shall be by a carrier selected by Omron; Omron will not drop ship except in "break down" situations.
  - b. Such carrier shall act as the agent of Buyer and delivery to such carrier shall constitute delivery to Buyer;
  - c. All sales and shipments of Products shall be FOB shipping point (unless otherwise stated in writing by Omron), at which point title and risk of loss shall pass from Omron to Buyer; provided that Omron shall retain a security interest in the Products until the full purchase price is paid;
  - d. Delivery and shipping dates are estimates only; and
  - e. Omron will package Products as it deems proper for protection against normal handling and extra charges apply to special conditions.
12. **Claims.** Any claim by Buyer against Omron for shortage or damage to the Products occurring before delivery to the carrier must be presented in writing to Omron within 30 days of receipt of shipment and include the original transportation bill signed by the carrier noting that the carrier received the Products from Omron in the condition claimed.
13. **Warranties.** (a) **Exclusive Warranty.** Omron's exclusive warranty is that the Products will be free from defects in materials and workmanship for a period of twelve months from the date of sale by Omron (or such other period expressed in writing by Omron). Omron disclaims all other warranties, express or implied. (b) **Limitations.** OMRON MAKES NO WARRANTY OR REPRESENTATION, EXPRESS OR IMPLIED, ABOUT NON-INFRINGEMENT, MERCHANTABILITY OR FITNESS FOR A PARTICULAR PURPOSE OF THE PRODUCTS. BUYER ACKNOWLEDGES THAT IT ALONE HAS DETERMINED THAT THE PRODUCTS WILL SUITABLY MEET THE REQUIREMENTS OF THEIR INTENDED USE. Omron further disclaims all warranties and responsibility of any type for claims or expenses based on infringement by the Products or otherwise of any intellectual property right. (c) **Buyer Remedy.** Omron's sole obligation hereunder shall be, at Omron's election, to (i) replace (in the form originally shipped with Buyer responsible for labor charges for removal or replacement thereof) the non-complying Product, (ii) repair the non-complying Product, or (iii) repay or credit Buyer an amount equal to the purchase price of the non-complying Product; provided that in no event shall Omron be responsible for warranty, repair, indemnity or any other claims or expenses regarding the Products unless Omron's analysis confirms that the Products were properly handled, stored, installed and maintained and not subject to contamination, abuse, misuse or inappropriate modification. Return of any Products by Buyer must be approved in writing by Omron before shipment. Omron Companies shall not be liable for the suitability or unsuitability or the results from the use of Products in combination with any electrical or electronic components, circuits, system assemblies or any other materials or substances or environments. Any advice, recommendations or information given orally or in writing, are not to be construed as an amendment or addition to the above warranty. See <http://www.omron247.com> or contact your Omron representative for published information.
14. **Limitation on Liability; Etc.** OMRON COMPANIES SHALL NOT BE LIABLE FOR SPECIAL, INDIRECT, INCIDENTAL, OR CONSEQUENTIAL DAMAGES, LOSS OF PROFITS OR PRODUCTION OR COMMERCIAL LOSS IN ANY WAY CONNECTED WITH THE PRODUCTS, WHETHER SUCH CLAIM IS BASED IN CONTRACT, WARRANTY, NEGLIGENCE OR STRICT LIABILITY. Further, in no event shall liability of Omron Companies exceed the individual price of the Product on which liability is asserted.
15. **Indemnities.** Buyer shall indemnify and hold harmless Omron Companies and their employees from and against all liabilities, losses, claims, costs and expenses (including attorney's fees and expenses) related to any claim, investigation, litigation or proceeding (whether or not Omron is a party) which arises or is alleged to arise from Buyer's acts or omissions under these Terms or in any way with respect to the Products. Without limiting the foregoing, Buyer (at its own expense) shall indemnify and hold harmless Omron and defend or settle any action brought against such Companies to the extent based on a claim that any Product made to Buyer specifications infringed intellectual property rights of another party.
16. **Property; Confidentiality.** Any intellectual property in the Products is the exclusive property of Omron Companies and Buyer shall not attempt to duplicate it in any way without the written permission of Omron. Notwithstanding any charges to Buyer for engineering or tooling, all engineering and tooling shall remain the exclusive property of Omron. All information and materials supplied by Omron to Buyer relating to the Products are confidential and proprietary, and Buyer shall limit distribution thereof to its trusted employees and strictly prevent disclosure to any third party.
17. **Export Controls.** Buyer shall comply with all applicable laws, regulations and licenses regarding (i) export of products or information; (ii) sale of products to "forbidden" or other proscribed persons; and (iii) disclosure to non-citizens of regulated technology or information.
18. **Miscellaneous.** (a) **Waiver.** No failure or delay by Omron in exercising any right and no course of dealing between Buyer and Omron shall operate as a waiver of rights by Omron. (b) **Assignment.** Buyer may not assign its rights hereunder without Omron's written consent. (c) **Law.** These Terms are governed by the law of the jurisdiction of the home office of the Omron company from which Buyer is purchasing the Products (without regard to conflict of law principles). (d) **Amendment.** These Terms constitute the entire agreement between Buyer and Omron relating to the Products, and no provision may be changed or waived unless in writing signed by the parties. (e) **Severability.** If any provision hereof is rendered ineffective or invalid, such provision shall not invalidate any other provision. (f) **Setoff.** Buyer shall have no right to set off any amounts against the amount owing in respect of this invoice. (g) **Definitions.** As used herein, "including" means "including without limitation"; and "Omron Companies" (or similar words) mean Omron Corporation and any direct or indirect subsidiary or affiliate thereof.

## Certain Precautions on Specifications and Use

1. **Suitability of Use.** Omron Companies shall not be responsible for conformity with any standards, codes or regulations which apply to the combination of the Product in the Buyer's application or use of the Product. At Buyer's request, Omron will provide applicable third party certification documents identifying ratings and limitations of use which apply to the Product. This information by itself is not sufficient for a complete determination of the suitability of the Product in combination with the end product, machine, system, or other application or use. Buyer shall be solely responsible for determining appropriateness of the particular Product with respect to Buyer's application, product or system. Buyer shall take application responsibility in all cases but the following is a non-exhaustive list of applications for which particular attention must be given: (i) Outdoor use, uses involving potential chemical contamination or electrical interference, or conditions or uses not described in this document. (ii) Use in consumer products or any use in significant quantities. (iii) Energy control systems, combustion systems, railroad systems, aviation systems, medical equipment, amusement machines, vehicles, safety equipment, and installations subject to separate industry or government regulations. (iv) Systems, machines and equipment that could present a risk to life or property. Please know and observe all prohibitions of use applicable to this Product. NEVER USE THE PRODUCT FOR AN APPLICATION INVOLVING SERIOUS RISK TO LIFE OR PROPERTY OR IN LARGE QUANTITIES WITHOUT ENSURING THAT THE SYSTEM AS A WHOLE HAS BEEN DESIGNED TO ADDRESS THE RISKS, AND THAT THE OMRON'S PRODUCT IS PROPERLY RATED AND INSTALLED FOR THE INTENDED USE WITHIN THE OVERALL EQUIPMENT OR SYSTEM.
2. **Programmable Products.** Omron Companies shall not be responsible for the user's programming of a programmable Product, or any consequence thereof.
3. **Performance Data.** Data presented in Omron Company websites, catalogs and other materials is provided as a guide for the user in determining suitability and does not constitute a warranty. It may represent the result of Omron's test conditions, and the user must correlate it to actual application requirements. Actual performance is subject to the Omron's Warranty and Limitations of Liability.
4. **Change in Specifications.** Product specifications and accessories may be changed at any time based on improvements and other reasons. It is our practice to change part numbers when published ratings or features are changed, or when significant construction changes are made. However, some specifications of the Product may be changed without any notice. When in doubt, special part numbers may be assigned to fix or establish key specifications for your application. Please consult with your Omron's representative at any time to confirm actual specifications of purchased Product.
5. **Errors and Omissions.** Information presented by Omron Companies has been checked and is believed to be accurate; however, no responsibility is assumed for clerical, typographical or proofreading errors or omissions.

Complete "Terms and Conditions of Sale" for product purchase and use are on Omron's website at [www.omron247.com](http://www.omron247.com) – under the "About Us" tab, in the Legal Matters section.

**ALL DIMENSIONS SHOWN ARE IN MILLIMETERS.**

To convert millimeters into inches, multiply by 0.03937. To convert grams into ounces, multiply by 0.03527.



**OMRON ELECTRONICS LLC**

1 Commerce Drive  
Schaumburg, IL 60173  
Tel: 847.843.7900

For U.S. technical support or other inquiries: 800.556.6766

**OMRON CANADA, INC.**

885 Milner Avenue  
Toronto, Ontario M1B 5V8  
Tel: 416.286.6465

**MEXICO SALES OFFICES**

**Mexico, D.F.** 555.660.3144  
**Ciudad Juárez** 656.623.7083  
**Monterrey, N.L.** 818.377.4281  
**Querétaro** 442.135.4510

**BRAZIL SALES OFFICE**

**Sao Paulo** 55.11.2101.6310

**ARGENTINA SALES OFFICE**

**Cono Sur** 54.114.787.1129

**CHILE SALES OFFICE**

**Santiago** 562.206.4592

**OTHER LATIN AMERICAN SALES**

[mela@omron.com](mailto:mela@omron.com)

**OMRON ON-LINE**

**Global -**

[www.omron.com](http://www.omron.com)

**USA -**

[www.omron247.com](http://www.omron247.com)

**Canada -**

[www.omron.ca](http://www.omron.ca)

**Brazil -**

[www.omron.com.br](http://www.omron.com.br)

**Latin America -**

[www.espanol.omron.com](http://www.espanol.omron.com)