



sitop



Power supplies
SITOP power
LOGO!Power

SIEMENS

Related catalogs

System Cabling SIMATIC TOP connect

KT 10.2

Order No.:
E86060-K2410-A201-A3-7600



Stromversorgungen SITOP power, LOGO!Power, SIDAC-S ¹⁾

PD 20

Order No.:
E86060-K2802-A101-A1



Low Voltage

LV 10

Order No.:
E86060-K1002-A101-A4-7600



SIMATIC Products for Totally Integrated Automation and Micro Automation

ST 70

Order No.:
E86060-K4670-A111-A9-7600



Industrial Communication

IK PI

Order No.:
E86060-K6710-A101-B4-7600



SINUMERIK & SIMODRIVE Automation Systems for Machine Tools

NC 60

Order No.:
E86060-K4460-A101-B1-7600



PC-based Automation

Order No.:
E86060-K4670-B111-B2-7600



Training for Information and Industrial Solutions ¹⁾

ITC

Order No.:
Paper: E86060-K6850-A101-B3
CD: E86060-D6850-A100-B7-7400



The offline Mall of Automation and Drives

CA 01

Order No.:
CD: E86060-D4001-A110-C3-7600



A&D Mall

Internet:
www.siemens.com/automation/mall



¹⁾ Available in German only.

Trademarks

All product designations may be trademarks or product names of Siemens AG or supplier companies whose use by third parties for their own purposes could violate the rights of the owners.

SITOP

Power supplies SITOP power LOGO!Power

Catalog KT 10.1 · 2004

Supersedes:
Catalog KT 10.1 · 2002

The products contained in this catalog
also appear in CD-ROM catalog CA 01
Order No.:
E86060-D4001-A110-C3-7600

Please contact your local Siemens
representative.

© Siemens AG 2004



The products and systems described in this catalog are manufactured/distributed under application of a certified quality management system in accordance with DIN EN ISO 9001 (Certified Registration No. 1108). The certificate is recognized by all IQNet countries.



SIEMENS

Introduction	Overview of product families, Selection guide	1
SITOP power, Standard 24 V	Single-phase, Output currents up to 2 A	2
	Single-phase, Output currents 2.5 to 4 A	3
	Single-phase and two-phase, Output current 5 A	4
	Single-phase and two-phase, Output current 10 A	5
	Single-phase and two-phase, Output currents 20 and 40 A	6
	Three-phase, Output currents 5 to 40 A	7
	Additional components	8
	Uninterruptible power supplies	9
SITOP power	Alternative voltages	10
SITOP power	AS interface power supplies	11
SITOP power	Customized	12
LOGO!Power		13
Technical information and configuration		14
Dimension drawings		15
Appendix	Contact persons Indexes	16

Welcome to Automation and Drives

We would like to welcome you to Automation and Drives and our comprehensive range of products, systems, solutions and services for production and process automation and building technology worldwide.

With Totally Integrated Automation and Totally Integrated Power, we deliver solution platforms based on standards that offer you a considerable savings potential.

Discover the world of our technology now. If you need more detailed information, please contact one of your regional Siemens partners.

They will be glad to assist you.



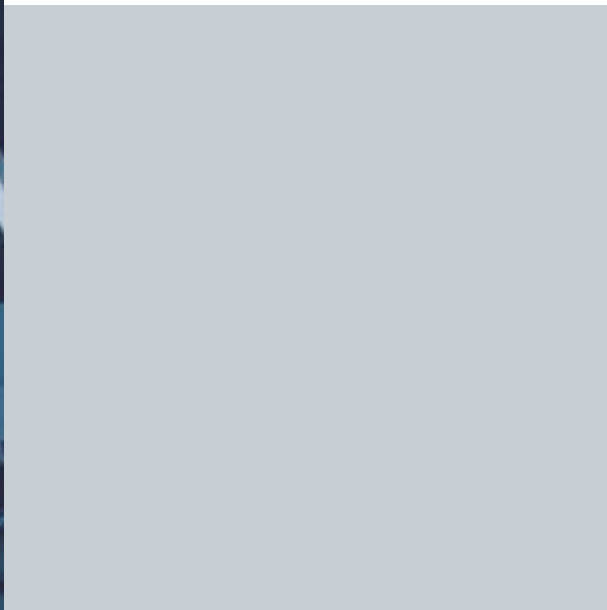

Totally Integrated Automation – innovations for more productivity

With the launch of Totally Integrated Automation, we were the first ones on the market to consistently implement the trend from equipment to an integrated automation solution, and have continuously improved the system ever since. Whether your industry is process- and production-oriented or a hybrid, Totally Integrated Automation is a unique "common solution" platform that covers all the sectors. Totally Integrated Automation is an integrated platform for the entire production line - from receiving to technical processing

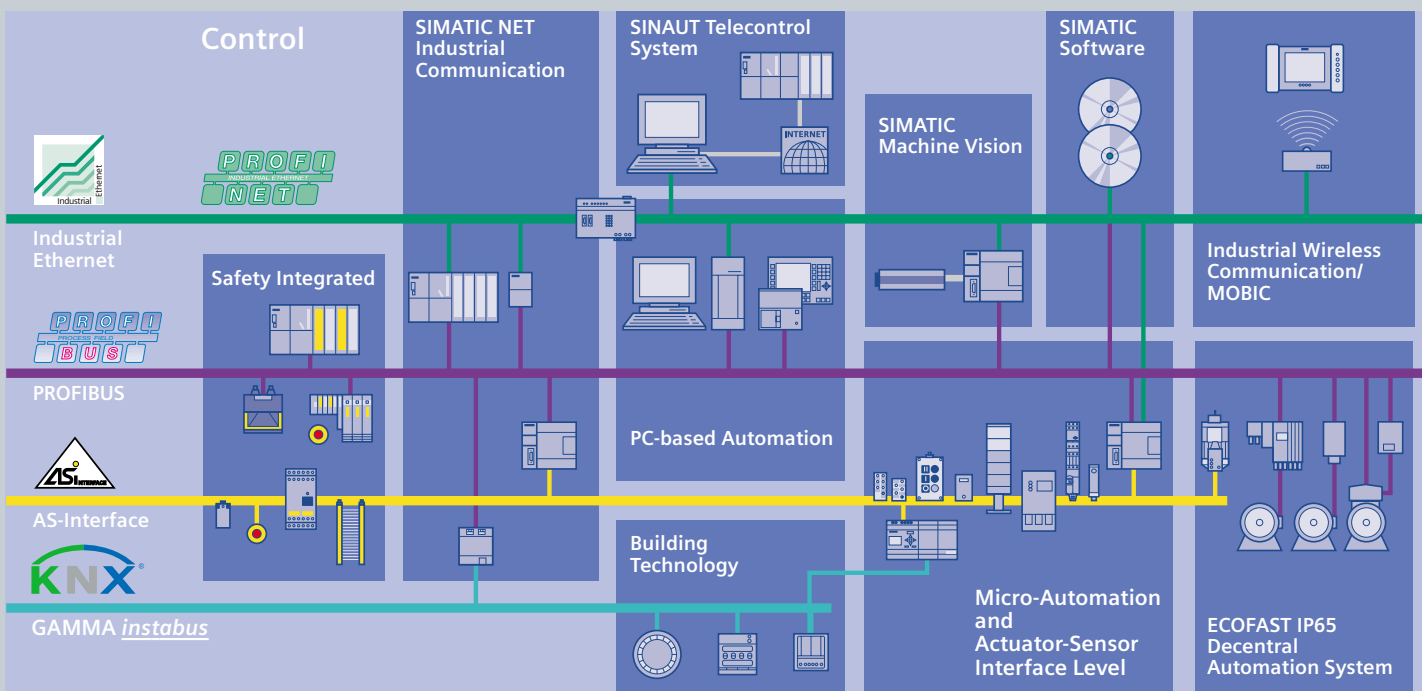
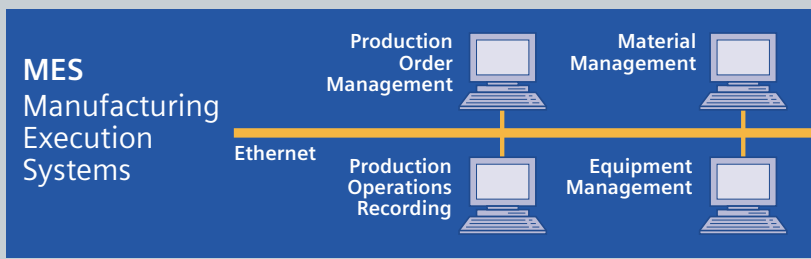

and production areas to shipping. Thanks to the system-oriented engineering environment, integrated, open communications as well as intelligent diagnostics options, your plant now benefits in every phase of the life cycle.

In fact, to this day we are the only company worldwide that can offer a control system based on an integrated platform for both the production and process industry.

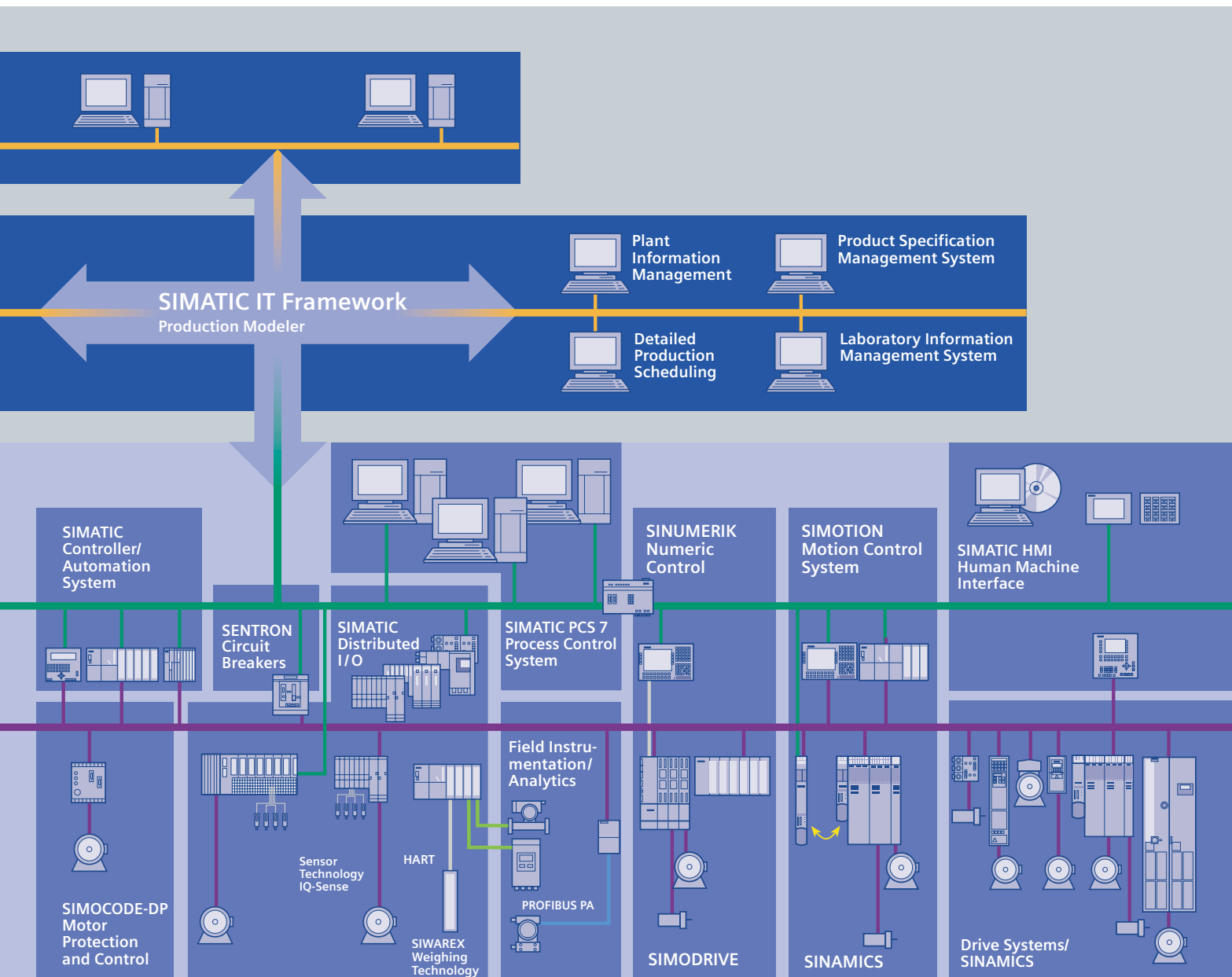

SITOP power Introduction

Overview of product families

SITOP modular

The innovative SITOP modular power supplies feature a completely new concept. The highlight is the modular design comprising a basic unit which can be supplemented by add-on modules with further functions. The modularity has no competition with respect to flexibility, simple handling and price/performance ratio.

The basic units

Compact and rugged basic units for 1-, 2- or 3-phase connection and with output currents from 5 A to 40 A are the basis of the stabilized 24 V supply. The 5 A and 10 A power supply units are unique, and can be connected to almost any network throughout the world thanks to their ultra-wide input range. Each basic unit can be fitted on a DIN rail and already has a comprehensive scope of functions.

- 5 A and 10 A devices with ultra-wide input range for 1- and 2-phase operation
- 20 A and 40 A devices for 1- or 3-phase operation
- Adjustable output voltage up to 28.8 V for compensation of voltage drops
- 3 LEDs for detailed signalling of the operating status
- Power boost up to three times the rated current
- Selectable short-circuit response: constant current or latching shutdown
- Selectable output characteristic for parallel operation



The add-on modules

The functionality of the basic units can be expanded using add-on modules. The power supply is optimally integrated into the overall system using the signalling module. Immediate response to various operating statuses is possible and potential damage can be avoided. The buffer module provides effective protection against brief power failures which could lead to a plant standstill, loss of data or even machine damage if the 24 V side is not buffered. A redundancy module can also be used to provide redundant power supply. Thus the 24 V supply is guaranteed even in the worst case when a faulty power supply unit would affect the unit connected in parallel.

The SITOP select diagnosis module

The diagnosis module is the optimum expansion for all 24 V power supplies in order to divide and monitor the load current among several branch circuits. An overload or short-circuit in a feeder is reliably detected and selectively switched-off. Total failures of plants can be prevented because the 24 V supply for the other loads is maintained. Detailed signalling permits fast fault locating, and thus the minimizing of downtimes.





SITOP DC UPS

The DC UPS modules provide optimum protection against longer power failures. DC UPS modules and battery modules expand SITOP power supply units with 24 V output voltage into uninterruptible power supplies with a rated output current up to 40 A. The transition from power supply mode to buffered mode is absolutely interruption-free. The DC UPS modules are provided as standard with all required protection and monitoring functions, thus providing high availability. The integral battery management function guarantees a long service life for the maintenance-free battery modules. Status messages concerning the operational readiness, battery status and battery lines are signaled by LEDs and floating contacts. The compact 6 A and 15 A DC UPS modules can also communicate via an interface, thus permitting simple integration into PC-based systems.

Tried and tested

The SITOP range of power supply units has proven its reliability for many years already. The units offer graded performances with output currents from 2 A to 20 A and from 10 A to 40 A for single-phase and three-phase incoming supplies respectively. Thanks to the simple handling and numerous certifications, the 24 V power supply units are also suitable for export-oriented use in all standard automation engineering applications. And should it be the case that the power supply conditions are unreliable in a global application, the proven SITOP power supplies can of course also be combined with the DC UPS modules.

The facets

The SITOP power supply units also cover individual power supply requirements - whether standard industrial applications, extreme ambient conditions, or unusual output voltages. The SITOP variants include some true all-rounders:

SITOP power 0.5: the mini devices with a width of only 22.5 mm are the narrowest in the SITOP family and are therefore particularly suitable for supplying low-voltage switchgear.

SITOP power flexi: unlimited variety thanks to a variable output. The innovative circuit concept permits flexible setting of the output voltage between 3 V and 52 V. Special voltages can therefore also be covered by a standard device.

SITOP power dual: the electronics supply for the switchgear cabinet. The DIN rail device is industry-compatible and has two 15 V outputs. For example, for electronic loads to be supplied with ± 15 V.

SITOP power 24 V/2.5 A, 4 A and 10 A: the devices with universal input can be connected to 1-phase AC voltage networks as well as to DC voltage networks.

SITOP power 24 V/20 A: the 2-phase primary switched-mode regulator with 20 A rated output current is predestined for industrial networks with high AC voltages. The special wide-range input allows connection to 3-phase networks with rated voltages between 500 V and 600 V.

SITOP power AS-Interface: 2 primary switched-mode regulators are available especially for powering the actuator/sensor interface: a 2.4 A version with 24 V DC input and IP65 degree of protection, and a 7 A version with wide-range input for AC and DC voltages.

The facets



SIMATIC design

SITOP in SIMATIC design

The SITOP power supply units were developed with a design based on the SIMATIC automation systems. However, their special features mean that they can also be optimally used in many other applications.

S7-200 design: 24 V/3.5 A. The flat power supply unit with the design of the micro PLC is also particularly suitable for applications with a small overall height and a small switchgear cabinet depth.

S7-300 design: 24 V/2 A, 5 A and 10 A. Designed as series-connected power supply units for the S7-300 CPUs, they can be simply snapped onto the S7 rail and connected to the CPU by means of a connecting comb. The 2 A and 5 A devices are also available as outdoor versions which are unaffected even by temperatures from -25 °C to +70 °C or increased shock and vibration load.

ET 200B design: 24 V/5 A and 10 A. The devices with a flat design are particularly suitable when only limited mounting depths are available. They find sufficient space even in covered machine racks or pivoted frames.

ET 200X design: 24 V/10 A. The 10 A power supply unit with IP65 degree of protection is suitable for the most rugged industrial applications. Permitting any mounting position, the power supply unit for distributed I/Os can handle ambient temperatures from -25 °C to +55 °C.



LOGO!Power

The mini power supply units are available in two performance classes for output voltages of 5 V, 12 V and 15 V, and in three performance classes for 24 V. Their flat, cascaded profile even permits installation in small distribution boards. The primary switched-mode regulators have been completely innovated and now require even less space for mounting, but with increased functionality. For example, the new function "Constant current in event of overload" even permits the connection of difficult loads. Wide-range input, wide temperature range and many certifications mean that the LOGO! power supply is a universal device for use in numerous applications.

LOGO!Power



Selection guide

In order to assist you in finding the right stabilized power supply for each application as quickly as possible, we have assembled the following table as an overview listing all power supplies con-

tained in this catalog sorted according to input voltage, output voltage and output current.

Selection guide

Output voltage	Output current	Order No.	Alternating voltage			Direct voltage		
			120 to 230 V AC	500 to 600 V two-phase AC	400 to 500 V three-phase AC	24 V DC	24 to 220 V DC	120 to 230 V DC
5 V DC	3 A	6EP1 311-1SH02	page 13/2					
	6.3 A	6EP1 311-1SH12	page 13/2					
12 V DC	1.9 A	6EP1 321-1SH02	page 13/4					
	4.5 A	6EP1 322-1SH02	page 13/4					
15 V DC	1.9 A	6EP1 351-1SH02	page 13/6					
	4 A	6EP1 352-1SH02	page 13/6					
	2x3.5 A	6EP1 353-0AA00	page 10/2					
24 V DC	0.375 A	6EP1 731-2BA00	page 2/2					
	0.5 A	6EP1 331-2BA10	page 2/2					
	1.3 A	6EP1 331-1SH02	page 13/8					
	2 A	6EP1 331-2BA00	page 2/2					
		6EP1 331-1SL11	page 2/3					
		6ES7 307-1BA00-0AA0	page 2/3					
		6ES7 305-1BA80-0AA0	page 2/3					
	2.5 A	6EP1 732-0AA00	page 2/3					
		6EP1 332-1SH12	page 3/2					
	2.5 A	6EP1 332-1SH42	page 13/8					
		6EP1 332-1SH31	page 3/2					
	3.5 A	6EP1 332-1SH22	page 3/2					
		6EP1 332-1SH51	page 13/8					
	5 A	6EP1 333-2BA00	page 4/2					
		6EP1 333-2AA00	page 4/2					
		6ES7 307-1EA80-0AA0	page 4/3					
		6ES7 307-1EA00-0AA0	page 4/3					
		6EP1 333-1AL12	page 4/3					
		6EP1 333-1SL11	page 4/3					
		6EP1 333-3BA00	page 4/2					
	10 A	6EP1 334-2BA00	page 5/2					
		6EP1 334-2AA00	page 5/2					
6EP1 334-2CA00		page 5/3						
6ES7 307-1KA01-0AA0		page 5/3						
6EP1 334-1SL12		page 5/3						
6EP1 334-1AL12		page 5/3						
6EP1 334-1SH01		page 5/3						
6EP1 434-2BA00		page 7/6						
6EP1 334-3BA00		page 5/2						
6EP1 434-2BA00		page 7/6						
6EP1 436-3BA00		page 7/3						
20 A	6EP1 336-3BA00	page 6/2						
	6EP1 336-2BA00	page 6/3						
	6EP1 536-2AA00	page 6/3						
20 A	6EP1 436-2BA00	page 7/6						
	6EP1 436-3BA00	page 7/3						
30 A	6EP1 437-2BA00	page 7/7						
40 A	6EP1 337-3BA00	page 6/2						
	6EP1 437-3BA00	page 7/3						
	6EP1 437-2BA10	page 7/7						

Continued on page 1/10.

Selection guide

Selection guide (continued)

Output voltage	Output current	Order No.	Alternating voltage			Direct voltage		
			120 to 230 V AC	500 to 600 V two-phase AC	400 to 500 V three-phase AC	24 V DC	24 to 220 V DC	120 to 230 V DC
24 V DC UPS	6 A	6EP1 931-2DC21						page 9/7
		6EP1 931-2DC31						page 9/7
		6EP1 931-2DC41						page 9/7
	15 A	6EP1 931-2EC21						page 9/9
		6EP1 931-2EC31						page 9/9
		6EP1 931-2EC41						page 9/9
	40 A	6EP1 931-2FC01						page 9/13
		1.2 Ah	6EP1 935-6MC01					page 9/14
		2.5 Ah	6EP1 935-6MD31					page 9/15
		3.2 Ah	6EP1 935-6MD11					page 9/16
		7 Ah	6EP1 935-6ME21					page 9/17
		12 Ah	6EP1 935-6MF01					page 9/18
	48 V DC	20 A	6EP1 457-3BA00					page 10/2
3-52 V DC	10 A/120 W	6EP1 353-2BA00	page 10/2					
30 V DC	2.4 A	6EP1 632-1AL01					page 11/2	
AS-Interface	7 A	6EP1 354-1AL01	page 11/2					
SITOP power 24 V, Additional components								
Signalling module		6EP1 961-3BA10						page 8/2
Buffer module	40 A	6EP1 961-3BA00						page 8/2
Redundancy module	20 A	6EP1 961-3BA20						page 8/2
Diagnosis module	4x10 A	6EP1 961-2BA00						page 8/4

SITOP power · Standard 24 V Single-phase

2



2/2
2/2
2/3
2/3
2/3

Output currents up to 2 A

The smallest
The proven type
The DC/DC converter
The S7-300 type
The outdoor variant



SITOP power · Standard 24 V

Single-phase

2

Output currents up to 2 A

Overview

The smallest



The proven type



Application

The optimum power supply units for automation solutions in the lower performance range; with wide-range input for AC or DC voltages; thanks to their compact and narrow design, they are particularly suitable for solutions where limited space is available and in conjunction with low-voltage switchgear.

The tried and tested power supply unit with selectable input voltage range for supplying all standard applications in automation engineering.

Technical specifications

Power supply, type	0.5 A	0.375 A	2 A
Order No.	6EP1 331-2BA10	6EP1 731-2BA00	6EP1 331-2BA00
Input	Single-phase AC	DC voltage	Single-phase AC
Rated voltage $V_{in \text{ rated}}$	120 to 230 V AC wide-range input	48 to 220 V DC wide-range input	120/230 V AC Settable using wire jumper
Voltage range	93 to 264 V AC	30 to 264 V DC (30 to 187 V AC)	93 to 132 V/187 to 264 V AC
Overvoltage strength	$2.3 \times V_{in \text{ rated}}$, 1.3 ms	-	$2.3 \times V_{in \text{ rated}}$, 1.3 ms
Mains buffering at $I_{out \text{ rated}}$	> 10 ms at $V_{in} = 230 \text{ V}$	> 10 ms at $V_{in} = 220 \text{ V}$	> 10 ms at $V_{in} = 93/187 \text{ V}$
Rated line frequency; range	50/60 Hz, 47 to 63 Hz	-	50/60 Hz; 47 to 63 Hz
Rated current $I_{in \text{ rated}}$	0.22 to 0.13 A	0.03 to 0.06 A	0.9/0.6 A
Inrush current limitation (+25 °C)	< 23 A, typ. 1 ms	< 35 A, typ. 3 ms	< 14 A, typ. 3 ms
I^2t	0.3 A ² s	1.2 A ² s	< 0.3 A ² s
Integrated line-side fuse	T 2 A/250 V (not accessible)	F 4 A/250 V (not accessible)	T 1.6 A/250 V (not accessible)
Recommended circuit-breaker (IEC 898) in mains supply line	From 3 A, Characteristic C	From 6 A, Characteristic C, DC-suitable	From 3 A, Characteristic C
Output	Stabilized, floating direct voltage	Stabilized, floating direct voltage	Stabilized, floating direct voltage
Rated voltage $V_{out \text{ rated}}$	24 V DC	24 V DC	24 V DC
Total tolerance	± 3 %	± 3 %	± 3 %
• Stat. mains compensation	Approx. ± 0.2 %	Approx. ± 0.1 %	Approx. 0.1 %
• Stat. load compensation	Approx. ± 0.7 %	Approx. ± 0.1 %	Approx. 0.8 %
Residual ripple (clock frequency: approx. 50 kHz)	< 150 mV _{pp} (typ. 50 mV _{pp})	< 150 mV _{pp} (typ. 50 mV _{pp})	< 150 mV _{pp}
Spikes (bandwidth: 20 MHz)	< 240 mV _{pp} (typ. 150 mV _{pp})	< 240 mV _{pp} (typ. 50 mV _{pp})	< 240 mV _{pp}
Setting range	-	-	22.8 to 26.4 V
Status display	Green LED for 24 V O.K.	Green LED for 24 V O.K.	Green LED for 24 V O.K.
Power ON/OFF behavior	No overshoot of V_{out} (soft start)	No overshoot of V_{out} (soft start)	No overshoot of V_{out} (soft start)
Starting delay/voltage rise	< 1.5 s/typ. 20 ms	< 2.5 s/typ. 90 ms	< 3 s/typ. 80 ms
Rated current $I_{out \text{ rated}}$	0.5 A	0.375 A	2 A
Current range	0 to 0.5 A	0 to 0.375 A	0 to 2 A
• Up to +45 °C	0 to 0.5 A	0 to 0.375 A	0 to 2 A
• Up to +60 °C	0 to 0.5 A (up to +70 °C)	0 to 0.375 A	0 to 2 A
Dyn. V/I with			
• Starting on short circuit	Approx. 0.6 A constant current	typ. 2.7 A for 200 ms	typ. 7 A for 300 ms
• Short-circuit in operation	Approx. 0.6 A constant current	Not permissible	Yes, 2
Parallel connection for increased output	Not permissible	Not permissible	Yes, 2

Continued on page 2/4.

SITOP power · Standard 24 V Single-phase

Output currents up to 2 A

2

The DC/DC converter



The DC/DC converter for supply from battery and DC networks, with a wide input voltage range from 38 V to 121 V DC.

The S7-300 type



The proven power supply in the SIMATIC S7-300 design; alternatively with PS-CPU connecting comb and for snap-mounting on S7 busbar (Order No. 6ES7307-1BA00-0AA0) or without PS-CPU connecting comb for snap-mounting on DIN rail EN 500022-35x15 via mounting adapter (Order No. 6EP1 331-1SL11).

The outdoor variant



The power supply unit for extreme environmental conditions with SIMATIC S7-300 design, can be snapped onto S7 rail; with PS-CPU connecting comb.

2 A

6EP1 732-0AA00

DC voltage
48 to 110 V DC
wide-range input

38 to 121 V DC

> 5 ms at $V_{in} = 48\text{ V}$
-
1.2 to 0.5 A
< 33 A

T 2.5 A (not accessible)
10 to 25 A, Characteristic B, or
6 to 25 A, Characteristic C,
DC-suitable

Stabilized, floating direct voltage
24 V DC
 $\pm 1\%$
Approx. 0.1 %
Approx. 0.4 %

< 100 mV_{pp}

< 300 mV_{pp}

-
Green LED for 24 V O.K.
Overshoots of V_{out} when
switching on max. 25 V

< 3 s/typ. 30 ms

2 A

0 to 2 A
0 to 2 A (up to +70 °C)

Yes, 2

2 A

6ES7307-1BA00-0AA0

Single-phase AC
120/230 V AC
Settable via selector switch on
device
85 to 132 V/170 to 264 V AC

$2.3 \times V_{in\text{ rated}}$, 1.3 ms
> 20 ms at $V_{in} = 93/187\text{ V}$
50/60 Hz, 47 to 63 Hz
0.9/0.6 A
< 20 A, < 3 ms

< 1.0 A²s
T 1.6 A/250 V (not accessible)
3 A, Characteristic C

Stabilized, floating direct voltage
24 V DC
 $\pm 3\%$
Approx. 0.1 %
Approx. 0.2 %

< 150 mV_{pp} (typ. < 20 mV_{pp})

< 240 mV_{pp} (typ. < 150 mV_{pp})

-
Green LED for 24 V O.K.
No overshoot of V_{out}
(soft start)

< 3 s/typ. 60 ms

2 A

0 to 2 A
0 to 2 A

typ. 10 A for 90 ms
typ. 10 A for 90 ms
Not permissible

2 A

6EP1 331-1SL11

Single-phase AC
120/230 V AC
Settable via selector switch on
device
85 to 132 V/170 to 264 V AC

$2.3 \times V_{in\text{ rated}}$, 1.3 ms
> 20 ms at $V_{in} = 93/187\text{ V}$
50/60 Hz, 47 to 63 Hz
0.9/0.6 A
< 20 A, < 3 ms

< 1.0 A²s
T 1.6 A/250 V (not accessible)
3 A, Characteristic C

Stabilized, floating direct voltage
24 V DC
 $\pm 3\%$
Approx. 0.1 %
Approx. 0.2 %

< 150 mV_{pp} (typ. < 20 mV_{pp})

< 240 mV_{pp} (typ. < 150 mV_{pp})

-
Green LED for 24 V O.K.
No overshoot of V_{out}
(soft start)

< 3 s/typ. 60 ms

2 A

0 to 2 A
0 to 2 A

typ. 10 A for 90 ms
typ. 10 A for 90 ms
Not permissible

2 A

6ES7 305-1BA80-0AA0 ¹⁾

DC voltage
24 to 110 V DC
wide-range input

16.8 to 138 V DC

154 V; 0.1 s
> 10 ms at $V_{in\text{ rated}}$
-
2.7 to 0.6 A (4 to 0.9 A)
< 20 A, < 10 ms

< 5 A²s
T 6.3 A/250 V (not accessible)
From 10 A, Characteristic C,
DC-suitable

Stabilized, floating direct voltage
24 V DC
 $\pm 3\%$
Approx. 0.2 %
Approx. 0.4 %

< 150 mV_{pp} (typ. < 30 mV_{pp})

< 240 mV_{pp} (typ. < 150 mV_{pp})

-
Green LED for 24 V O.K.
No overshoot of V_{out}
(soft start)

< 3 s (typ. 7 ms)/typ. 5 ms

2 A (3 A at $V_{in} > 24\text{ V}$)

0 to 2 A (3 A)
0 to 2 A (3 A)

typ. 9 A for 270 ms
typ. 9 A for 270 ms
Yes, 2

Continued on page 2/5.

1) SIPLUS module 6AG1 307-1BA80-2AA0 for enhanced temperature range -25 to +60 °C and use under medium load (e.g. chlorine/sulfur atmosphere). Conformity with EN 50155 available soon (electrical equipment on track vehicles).

SITOP power · Standard 24 V

Single-phase

2

Output currents up to 2 A

Power supply, type	0.5 A	0.375 A	2 A
Order No.	6EP1 331-2BA10	6EP1 731-2BA00	6EP1 331-2BA00
Efficiency			
Efficiency at $V_{out rated}$, $I_{out rated}$	Approx. 74 %	Approx. 66 %	Approx. 82 %
Power loss at $V_{out rated}$, $I_{out rated}$	Approx. 4.2 W	Approx. 4.6 W	Approx. 11 W
Control			
Dyn. mains compensation ($V_{in rated} \pm 15\%$)	Approx. $\pm 0.3\% V_{out}$	Approx. $\pm 0.3\% V_{out}$	Approx. $\pm 0.3\% V_{out}$
Dyn. load compensation ($I_{out}: 50/100/50\%$)	$\pm 0.7\% V_{out}$	$\pm 0.4\% V_{out}$	$\pm 2\% V_{out}$
Settling time			
• Load step from 50 to 100 %	typ. 1.5 ms	typ. 2 ms	typ. 0.5 ms
• Load step from 100 to 50 %	typ. 1.5 ms	typ. 2 ms	typ. 0.5 ms
Protection and monitoring			
Output overvoltage protection	Yes, acc. to EN 60950	Yes, acc. to EN 60950	Yes, acc. to EN 60950
Current limitation	0.55 to 0.65 A	0.41 to 0.49 A	typ. 2.2 to 2.6 A
Short-circuit protection	Stabilized current characteristic down to 0 V	Electronic shutdown, automatic restart	Electronic shutdown, automatic restart
RMS sustained short-circuit current	< 0.65 A	< 0.9 A	< 4 A
Overload/short-circuit indicator	-	-	-
Safety			
Galvanic isolation primary/secondary	Yes, SELV output voltage V_{out} acc. to EN 60950 and EN 50178	Yes, SELV output voltage V_{out} acc. to EN 60950 and EN 50178	Yes, SELV output voltage V_{out} acc. to EN 60950
Protective class	Class I	Class I	Class I
Discharge current	< 3.5 mA	< 3.5 mA	< 3.5 mA (typ. 0.17 mA)
TÜV test	Yes	Yes	Yes; CB scheme
CE marking	Yes	Yes	Yes
UL/cUL (CSA) approval	Yes, cULus listed (UL 508, CSA 22.2 No. 14-95), File E143289; cURus recognized (UL 60950, CSA 22.2 No. 60950), File E151273	Yes, cULus listed (UL 508, CSA 22.2 No. 14-95), File E143289; cURus recognized (UL 60950, CSA 22.2 No. 60950), File E151273	Yes, UL listed (UL 508) File E143289, CSA (CSA 22.2 No. 14-95)
FM approval	-	-	-
Appr. for use in marine vessels	-	-	-
Degree of protection (EN 60529)	IP20	IP20	IP20
EMC			
Interference emission	EN 55022 Class B	EN 55022 Class B	EN 55022 Class B
Line harmonics limitation	Not applicable	Not applicable	Not applicable
Interference immunity	EN 61000-6-2	EN 61000-6-2	EN 61000-6-2
Operating specifications			
Ambient temperature range	-20 to +70 °C with natural convection	-20 to +70 °C with natural convection, derating above 60 °C	0 to +60 °C with natural convection
Transportation and storage temperature range	-40 to +70 °C	-40 to +70 °C	-25 to +85 °C
Humidity rating	Climatic class 3K3 acc. to EN 60721, no condensation	Climatic class 3K3 acc. to EN 60721, no condensation	Climatic class 3K3 acc. to EN 60721, no condensation
Mechanical specifications			
Connections			
• Mains input L, N, PE (DC input: L+1, M1, PE)	One screw-type terminal each for 0.5 to 2.5 mm ² single-core/finely stranded	One screw-type terminal each for 0.5 to 2.5 mm ² single-core/finely stranded	One screw-type terminal each for 0.5 to 2.5 mm ² single-core/finely stranded
• Output L+	1 screw-type terminal for 0.5 to 2.5 mm ²	1 screw-type terminal for 0.5 to 2.5 mm ²	1 screw-type terminal for 0.5 to 2.5 mm ²
• Output M	2 screw-type terminals for 0.5 to 2.5 mm ²	2 screw-type terminals for 0.5 to 2.5 mm ²	2 screw-type terminals for 0.5 to 2.5 mm ²
Dimensions (W x H x D) in mm	22.5 x 80 x 91	22.5 x 80 x 91	50 x 125 x 125
Weight approx.	0.11 kg	0.14 kg	0.38 kg
Mounting	Snap-mounting on DIN rail EN 50022-35x15/7.5	Snap-mounting on DIN rail EN 50022-35x15/7.5	Snap-mounting on DIN rail EN 50022-35x15/7.5
Accessories	-	-	-

SITOP power · Standard 24 V Single-phase

Output currents up to 2 A

2

2 A	2 A	2 A	2 A
6EP1 732-0AA00	6ES7307-1BA00-0AA0	6EP1 331-1SL11	6ES7 305-1BA80-0AA0
Approx. 84 % Approx. 9 W	Approx. 83 % Approx. 10 W	Approx. 83 % Approx. 10 W	Approx. 75 % Approx. 16 W (24 W)
± 0.3 % V _{out} ± 0.8 % V _{out}	± 0.3 % V _{out} ± 0.8 % V _{out}	± 0.3 % V _{out} ± 0.8 % V _{out}	± 0.3 % V _{out} ± 2.5 % V _{out}
< 5 ms (typ. 2.5 ms) < 5 ms (typ. 2.5 ms)	< 5 ms (typ. 2.5 ms) < 5 ms (typ. 2.5 ms)	< 5 ms (typ. 2.5 ms) < 5 ms (typ. 2.5 ms)	< 5 ms (typ. 2.5 ms) < 5 ms (typ. 2.5 ms)
Yes, suppressor diode at output typ. 2.1 to 3 A	Additional control loop, shut-down at approx. 30 V, automatic restart 2.2 to 2.6 A	Additional control loop, shut-down at approx. 30 V, automatic restart 2.2 to 2.6 A	Additional control loop, shut-down at approx. 30 V, automatic restart 3.3 to 3.9 A
Electronic shutdown, automatic restart < 2 A -	Electronic shutdown, automatic restart < 4 A -	Electronic shutdown, automatic restart < 4 A -	Electronic shutdown, automatic restart < 2 A -
Yes, SELV output voltage V _{out} acc. to EN 60950	Yes, SELV output voltage V _{out} acc. to EN 60950 and EN 50178	Yes, SELV output voltage V _{out} acc. to EN 60950 and EN 50178	Yes, SELV output voltage V _{out} acc. to EN 60950 and EN 50178, clearance and creepage distances > 5 mm
Class I < 3.5 mA (typ. 0.7 mA) -	Class I < 3.5 mA (typ. 0.7 mA) Yes	Class I < 3.5 mA (typ. 0.7 mA) Yes	Class I < 3.5 mA (typ. 0.7 mA) Yes
Yes Yes, cULus listed (UL 508, CSA 22.2 No. 14-M91), File E179336	Yes Yes, UL listed (UL 508), File E143289, CSA (CSA 22.2 No. 14-95)	Yes Yes, UL listed (UL 508), File E143289, CSA (CSA 22.2 No. 14-95)	Yes Yes, UL listed (UL 508), File E143289, CSA (CSA 22.2 No. 14-95)
- - IP20	Yes, Class I Div. 2 Group A, B, C, D T4 in the S7-300 system IP20	Yes, Class I Div. 2 Group A, B, C, D T4 in the S7-300 system IP20	- Yes, GL, LRS IP20
EN 55022 Class B Not applicable EN 61000-6-2	EN 55022 Class B Not applicable EN 61000-6-2	EN 55022 Class B Not applicable EN 61000-6-2	EN 55011 Class A Not applicable EN 61000-6-2
0 to +70 °C with natural convection -40 to +70 °C	0 to +60 °C with natural convection -40 to +85 °C	0 to +60 °C with natural convection -40 to +85 °C	-25 to +70 °C with natural convection -40 to +85 °C
Climatic class 3K3 acc. to EN 60721, no condensation	Climatic class 3K3 acc. to EN 60721, no condensation	Climatic class 3K3 acc. to EN 60721, no condensation	Climatic class 3K5 acc. to EN 60721, brief condensation permissible
One screw-type terminal each for 2 x 0.5 to 2.5/1.5 mm ² single-core/finely stranded 1 screw-type terminal for 2 x 0.5 to 2.5 mm ² 1 screw-type terminal for 2 x 0.5 to 2.5 mm ²	One screw-type terminal each for 0.5 to 2.5 mm ² single-core/finely stranded 2 screw-type terminals for 0.5 to 2.5 mm ² 2 screw-type terminals for 0.5 to 2.5 mm ²	One screw-type terminal each for 0.5 to 2.5 mm ² single-core/finely stranded 2 screw-type terminals for 0.5 to 2.5 mm ² 2 screw-type terminals for 0.5 to 2.5 mm ²	One screw-type terminal each for 0.5 to 2.5 mm ² single-core/finely stranded 3 screw-type terminals for 0.5 to 2.5 mm ² 3 screw-type terminals for 0.5 to 2.5 mm ²
80 x 135 x 120 0.5 kg Snap-mounting on DIN rail EN 50022-35x15	50 x 125 x 120 0.42 kg Snap-mounting on S7 rail	50 x 125 x 135 0.42 kg Snap-mounting on DIN rail EN 50022-35x15	80 x 125 x 120 0.75 kg Snap-mounting on S7 rail
-	Mounting adapter for DIN rail and PS-CPU connecting comb	Mounting adapter for DIN rail and PS-CPU connecting comb	Mounting adapter for DIN rail and PS-CPU connecting comb

SITOP power · Standard 24 V

Single-phase

2

Notes



SITOP power · Standard 24 V Single-phase

3



3/2
3/2

Output currents 2.5 to 4 A

The universal types

The S7-200 type



SITOP power · Standard 24 V Single-phase

Output currents 2.5 to 4 A

3

Overview

The universal types



The S7-200 type



Application

The universal power supply units for all supply networks, with a wide-range input from 93 V to 264 V AC and 110 V to 350 V DC for supply from all typical networks.

Power supply unit whose design and functionality are optimally matched to the SIMATIC S7-200 micro PLC; flat design, particularly suitable for low control cabinet depths.

Technical specifications

Power supply, type	2.5 A	4 A	3.5 A
Order No.	6EP1 332-1SH12	6EP1 332-1SH22	6EP1 332-1SH31
Input	Single-phase AC or DC 120 to 230 V AC wide-range input	Single-phase AC or DC 120 to 230 V AC wide-range input	Single-phase AC 120/230 V AC Settable using wire jumper
Rated voltage $V_{in \text{ rated}}$	93 to 264 V AC or 110 to 350 V DC	93 to 264 V AC or 110 to 350 V DC	93 to 132 V/187 to 264 V AC
Voltage range			
Overvoltage strength	$2.3 \times V_{in \text{ rated}}$, 1.3 ms	$2.3 \times V_{in \text{ rated}}$, 1.3 ms	$2.3 \times V_{in \text{ rated}}$, 1.3 ms
Mains buffering at $I_{out \text{ rated}}$	> 20 ms at $V_{in} = 120 \text{ V}$, > 80 ms (typ. 100 ms) at $V_{in} = 187 \text{ V}$	> 20 ms at $V_{in} = 120 \text{ V}$, > 80 ms (typ. 100 ms) at $V_{in} = 187 \text{ V}$	> 20 ms at $V_{in} = 187 \text{ V}$
Rated line frequency; range	0/50/60 Hz, 47 to 63 Hz	0/50/60 Hz, 47 to 63 Hz	50/60 Hz, 47 to 63 Hz
Rated current $I_{in \text{ rated}}$	1.3 to 0.7 A	1.8 to 1.1 A	1.65/0.95 A
Inrush current limitation (+25 °C)	< 33 A, < 3 ms ($V_{in} = 230 \text{ V}$)	< 33 A, < 3 ms ($V_{in} = 230 \text{ V}$)	< 33 A, < 3 ms ($V_{in} = 230 \text{ V}$)
I^2t	< 3.5 A ² s	< 3.5 A ² s	< 1.0 A ² s
Integrated line-side fuse	T 3.15 A (not accessible)	T 3.15 A (not accessible)	T 2.5 A/250 V (not accessible)
Recommended circuit-breaker (IEC 898) in mains supply line	Two-pole circuit-breaker from 10 A, Characteristic C or from 6 A, Characteristic D	Two-pole circuit-breaker from 10 A, Characteristic C or from 6 A, Characteristic D	Two-pole circuit-breaker from 10 A, Characteristic C or from 6 A, Characteristic D
Output	Stabilized, floating direct voltage 24 V DC	Stabilized, floating direct voltage 24 V DC	Stabilized, floating direct voltage 24 V DC
Rated voltage $V_{out \text{ rated}}$			
Total tolerance	± 1 %	± 1 %	± 5 % (typ. ± 2 %)
• Stat. mains compensation	Approx. ± 0.1 %	Approx. ± 0.1 %	Approx. ± 0.1 %
• Stat. load compensation	Approx. ± 0.2 %	Approx. ± 0.2 %	Approx. ± 0.2 %
Residual ripple (clock frequency: approx. 50 kHz)	< 50 mV _{pp} (typ. 40 mV _{pp})	< 50 mV _{pp} (typ. 40 mV _{pp})	< 150 mV _{pp} (typ. 30 mV _{pp})
Spikes (bandwidth: 20 MHz)	< 100 mV _{pp} (typ. 40 mV _{pp})	< 100 mV _{pp} (typ. 40 mV _{pp})	< 240 mV _{pp} (typ. 110 mV _{pp})
Setting range	-	-	-
Status display	Green LED for 24 V O.K.	Green LED for 24 V O.K.	-
Power ON/OFF behavior	No overshoot of V_{out} (soft start)	No overshoot of V_{out} (soft start)	No overshoot of V_{out} (soft start)
Starting delay/voltage rise	< 0.6 s/typ. 20 ms	< 0.6 s/typ. 20 ms	< 1 s/typ. 80 ms
Rated current $I_{out \text{ rated}}$	2.5 A	4 A	3.5 A
Current range			
• Up to +45 °C	0 to 2.5 A	0 to 4 A	0 to 3.5 A
• Up to +60 °C	0 to 2.5 A	0 to 2.5 A	0 to 3.5 A
Dyn. V/I with			
• Starting on short circuit	Approx. 2.8 A constant current	Approx. 4.4 A constant current	typ. 5 A for 100 ms
• Short-circuit in operation	Approx. 2.8 A constant current	Approx. 4.4 A constant current	typ. 5 A for 100 ms
Parallel connection for increased output	Yes, up to 10	Yes, up to 10	Yes, up to 5

Continued on page 3/3.

SITOP power · Standard 24 V Single-phase

Output currents 2.5 to 4 A

3

Power supply, type	2.5 A	4 A	3.5 A
Order No.	6EP1 332-1SH12	6EP1 332-1SH22	6EP1 332-1SH31
Efficiency			
Efficiency at $V_{out rated}$, $I_{out rated}$	Approx. 85 %	Approx. 85 %	Approx. 84 %
Power loss at $V_{out rated}$, $I_{out rated}$	Approx. 11 W	Approx. 17 W	Approx. 16 W
Control			
Dyn. mains compensation, typ. ($V_{in rated} \pm 15\%$)	$\pm 0.3\% V_{out}$	$\pm 0.3\% V_{out}$	$\pm 0.3\% V_{out}$
Dyn. load compensation (I_{out} : 50/100/50 %)	typ. $\pm 0.5\% V_{out}$	typ. $\pm 0.5\% V_{out}$	$< \pm 10\% V_{out}$ (typ. $\pm 3\% V_{out}$)
Settling time			
• Load step from 50 to 100 %	< 2 ms (typ. 1 ms)	< 2 ms (typ. 1 ms)	< 5 ms
• Load step from 100 to 50 %	< 2 ms (typ. 1 ms)	< 2 ms (typ. 1 ms)	< 5 ms
Protection and monitoring			
Output overvoltage protection			
Current limitation	2.8 A	4.4 A	3.8 A
Short-circuit protection	Stabilized current characteristic down to 0 V	Stabilized current characteristic down to 0 V	Stabilized current characteristic to typ. 14 V, electronic shut-down below that, automatic restart
RMS sustained short-circuit current	< 3 A	< 5 A	< 4 A
Overload/short-circuit indicator	-	-	-
Safety			
Galvanic isolation primary/secondary	Yes, SELV output voltage V_{out} acc. to EN 60950	Yes, SELV output voltage V_{out} acc. to EN 60950	Yes, SELV output voltage V_{out} acc. to EN 60950
Protective class	Class I	Class I	Class I
Discharge current	< 3.5 mA	< 3.5 mA	< 3.5 mA
TÜV test	Yes	Yes	Yes
CE marking	Yes	Yes	Yes
UL/cUL (CSA) approval	Yes, cULus listed (UL 508, CSA 22.2 No. 14-M91), File E143289	Yes, cULus listed (UL 508, CSA 22.2 No. 14-M91), File E143289	Yes, cULus listed (UL 508, CSA 22.2 No. 14-M91), File E143289
FM approval	-	-	-
Appr. for use in marine vessels	-	-	-
Degree of protection (EN 60529)	IP20	IP20	IP20
EMC			
Interference emission	EN 55022 Class B	EN 55022 Class B	EN 55022 Class B
Line harmonics limitation	Not applicable	-	EN 61000-3-2
Interference immunity	EN 61000-6-2	EN 61000-6-2	EN 61000-6-2
Operating specifications			
Ambient temperature range	0 to +60 °C with natural convection	0 to +50 °C with natural convection	0 to +60 °C with natural convection
Transportation and storage temperature range	-25 to +85 °C	-25 to +85 °C	-25 to +85 °C
Humidity rating	Climatic class 3K3 acc. to EN 60721, no condensation	Climatic class 3K3 acc. to EN 60721, no condensation	Climatic class 3K3 acc. to EN 60721, no condensation
Mechanical specifications			
Connections			
• Mains input L, N, PE	One screw-type terminal each for 2 x 0.5 to 1.5 mm ² finely stranded, 2 x 0.5 to 2.5 mm ² single-core	One screw-type terminal each for 2 x 0.5 to 1.5 mm ² finely stranded, 2 x 0.5 to 2.5 mm ² single-core	One screw-type terminal each for 0.5 to 1 mm ² finely stranded, 0.5 to 1.5 mm ² single-core
• Output L+	1 screw-type terminal for 2 x 0.5 to 2.5 mm ²	1 screw-type terminal for 2 x 0.5 to 2.5 mm ²	1 screw-type terminal for 0.5 to 1 mm ²
• Output M	1 screw-type terminal for 2 x 0.5 to 2.5 mm ²	1 screw-type terminal for 2 x 0.5 to 2.5 mm ²	2 screw-type terminals for 0.5 to 1 mm ²
Dimensions (W x H x D) in mm	80 x 135 x 120	80 x 135 x 120	160 x 80 x 62
Weight approx.	0.5 kg	0.5 kg	0.5 kg
Mounting	Snap-mounting on DIN rail EN 50022-35x15, wall mounting	Snap-mounting on DIN rail EN 50022-35x15, wall mounting	Snap-mounting on DIN rail EN 50022-35x15/7.5, wall mounting
Accessories	-	-	Mounting bracket

SITOP power · Standard 24 V

Single-phase

Notes

3



SITOP power · Standard 24 V Single-phase and two-phase

4



4/2
4/2
4/3
4/3
4/3

Output current 5 A

SITOP modular
The proven types
The S7-300 type
The outdoor variant
The flat design



SITOP power · Standard 24 V

Single-phase and two-phase

Output current 5 A

Overview

SITOP modular



The proven types



Application

The modular power supply unit with single-phase and two-phase wide-range inputs for global use in many different fields of application; expansion of functions possible using add-on modules.

The tried and tested power supply unit with selectable input voltage range for supplying all standard applications in automation engineering; 6EP1333-2AA00 without limitation of input current harmonics.

Technical specifications

Power supply, type	5 A	5 A	5 A
Order No.	6EP1 333-3BA00	6EP1 333-2BA00	6EP1 333-2AA00
Input	Single and two-phase AC	Single-phase AC	Single-phase AC
Rated voltage $V_{in \text{ rated}}$	120/230 to 500 V AC Settable via selector switch on device	120/230 V AC Settable using wire jumper	120/230 V AC Settable using wire jumper
Voltage range	85 to 132 V/176 to 550 V AC	93 to 132 V/187 to 264 V AC	93 to 132 V/187 to 264 V AC
Overvoltage strength	1300 V_{peak} , 1.3 ms	$2.3 \times V_{in \text{ rated}}$, 1.3 ms	$2.3 \times V_{in \text{ rated}}$, 1.3 ms
Mains buffering at $I_{out \text{ rated}}$	> 25 ms at $V_{in} = 120/230 \text{ V}$	> 10 ms at $V_{in} = 93/187 \text{ V}$	> 20 ms at $V_{in} = 93/187 \text{ V}$
Rated line frequency; range	50/60 Hz; 47 to 63 Hz	50/60 Hz; 47 to 63 Hz	50/60 Hz; 47 to 63 Hz
Rated current $I_{in \text{ rated}}$	2.2 / 1.2 to 0.61 A	2.2/0.9 A	2.2/1.3 A
Inrush current limitation (+25 °C)	< 35 A	< 32 A, typ. 3 ms	< 32 A, typ. 3 ms
I^2t	< 1.7 A ² s	< 0.8 A ² s	< 0.8 A ² s
Integrated line-side fuse	T 3, 15 A (not accessible)	T 3, 15 A/250 V (not accessible)	T 3, 15 A/250 V (not accessible)
Recommended circuit-breaker (IEC 898) in mains supply line	From 6 A (10 A) Characteristic C (B); with two-phase operation: circuit-breaker with two-pole connection or motor circuit-breaker 3RV1021-1EA10	From 6 A, Characteristic C	From 6 A, Characteristic C
Output	Stabilized, floating direct voltage	Stabilized, floating direct voltage	Stabilized, floating direct voltage
Rated voltage $V_{out \text{ rated}}$	24 V DC	24 V DC	24 V DC
Total tolerance	± 3 %	± 3 %	± 3 %
• Stat. mains compensation	Approx. 0.1 %	Approx. 0.1 %	Approx. 0.1 %
• Stat. load compensation	Approx. 0.1 %	Approx. 0.2 %	Approx. 0.2 %
Residual ripple (clock frequency: approx. 50 kHz)	< 50 mV _{pp} (typ. 10 mV _{pp})	< 150 mV _{pp}	< 150 mV _{pp}
Spikes (bandwidth: 20 MHz)	< 200 mV _{pp} (typ. 20 mV _{pp})	< 240 mV _{pp}	< 240 mV _{pp}
Setting range	24 to 28.8 V (max. 120 W)	22.8 to 26.4 V	22.8 to 26.4 V
Status display	Green LED for 24 V O.K.	Green LED for 24 V O.K.	Green LED for 24 V O.K.
Power ON/OFF behavior	Overshoot of V_{out} approx. 3 %	No overshoot of V_{out} (soft start)	No overshoot of V_{out} (soft start)
Starting delay/voltage rise	< 1 s / < 50 ms	< 3 s / typ. 80 ms	< 3 s / typ. 80 ms
Rated current $I_{out \text{ rated}}$	5 A	5 A	5 A
Current range	0 to 5 A	0 to 5 A	0 to 5 A
• Up to +45 °C	0 to 5 A	0 to 5 A	0 to 5 A
• Up to +60 °C	0 to 5 A	0 to 5 A	0 to 5 A
Dyn. V/I with			
• Starting on short circuit	Approx. 5.5 A constant current	typ. 20 A for 350 ms	typ. 20 A for 350 ms
• Short-circuit in operation	typ. 15 A for 25 ms	Yes, 2	Yes, 2
Parallel connection for increased output	Yes, 2 (selectable current characteristic)		

Continued on page 4/4.

SITOP power · Standard 24 V

Single-phase and two-phase

Output current 5 A

The S7-300 type



The outdoor variant



The flat design



The proven power supply in the SIMATIC S7-300 design; alternatively with PS-CPU connecting comb for snap-mounting on S7 busbar (Order No. 6ES7307-1EA00-0AA0) or without PS-CPU connecting comb for snap-mounting on DIN rail EN 50002-35x15 via mounting adapter (Order No. 6EP1 333-1SL11).

The power supply unit for extreme environmental conditions with SIMATIC S7-300 design, can be snapped onto S7 rail; with PS-CPU connecting comb.

The flat design which is of great advantage where only low mounting depths are available, e.g. for use with distributed I/O, in machine benches or alcoves; design matched to SIMATIC ET 200B.

4

5 A	5 A	5 A	5 A
6ES7 307-1EA00-0AA0	6EP1 333-1SL11	6ES7 307-1EA80-0AA0¹⁾	6EP1 333-1AL12
Single-phase AC 120/230 V AC Settable via selector switch on device 85 to 132 V/170 to 264 V AC	Single-phase AC 120/230 V AC Settable via selector switch on device 85 to 132 V/170 to 264 V AC	Single-phase AC 120/230 V AC Settable via selector switch on device 93 to 132 V/187 to 264 V AC	Single-phase AC 120/230 V AC Settable via selector switch on device 85 to 132 V/170 to 264 V AC
2.3 x V _{in rated} , 1.3 ms > 20 ms at V _{in} = 93/187 V 50/60 Hz; 47 to 63 Hz 2.1/1.3 A < 45 A, < 3 ms < 1.2 A ² s F 4 A/250 V (not accessible) From 6 A, Characteristic C	2.3 x V _{in rated} , 1.3 ms > 20 ms at V _{in} = 93/187 V 50/60 Hz; 47 to 63 Hz 2.1/1.3 A < 45 A, < 3 ms < 1.2 A ² s F 4 A/250 V (not accessible) From 6 A, Characteristic C	2.3 x V _{in rated} , 1.3 ms > 20 ms at V _{in} = 93/187 V 50/60 Hz, 47 to 63 Hz 2.1/1.2 A < 45 A, < 3 ms < 1.8 A ² s (typ. 1.2 A ² s) T 3.15 A/250 V (not accessible) From 10 A, Characteristic C or from 6 A, Characteristic D	2.3 x V _{in rated} , 1.3 ms > 20 ms at V _{in} = 93/187 V 50/60 Hz; 47 to 63 Hz 2.2/1.2 A < 32 A, < 3 ms < 0.8 A ² s T 3.15 A/250 V (not accessible) From 6 A, Characteristic C
Stabilized, floating direct voltage 24 V DC ± 3 % Approx. 0.1 % Approx. 0.2 % < 150 mV _{pp} (typ. 40 mV _{pp}) < 240 mV _{pp} (typ. 90 mV _{pp}) - Green LED for 24 V O.K. No overshoot of V _{out} (soft start) < 2 s/typ. 60 ms 5 A 0 to 5 A 0 to 5 A	Stabilized, floating direct voltage 24 V DC ± 3 % Approx. 0.1 % Approx. 0.2 % < 150 mV _{pp} (typ. 40 mV _{pp}) < 240 mV _{pp} (typ. 90 mV _{pp}) - Green LED for 24 V O.K. No overshoot of V _{out} (soft start) < 2 s/typ. 60 ms 5 A 0 to 5 A 0 to 5 A	Stabilized, floating direct voltage 24 V DC ± 3 % Approx. ± 0.2 % Approx. ± 0.4 % < 150 mV _{pp} (typ. 40 mV _{pp}) < 240 mV _{pp} (typ. 90 mV _{pp}) - Green LED for 24 V O.K. No overshoot of V _{out} (soft start) < 3 s/typ. 100 ms 5 A 0 to 5 A 0 to 5 A	Stabilized, floating direct voltage 24 V DC ± 1 % Approx. 0.1 % Approx. 0.5 % < 150 mV _{pp} (typ. 40 mV _{pp}) < 240 mV _{pp} (typ. 100 mV _{pp}) 22 to 29 V Green LED for 24 V O.K. No overshoot of V _{out} (soft start) < 2 s/typ. 40 ms 5 A 0 to 5 A 0 to 5 A
typ. 20 A for 75 ms typ. 20 A for 75 ms Not permissible	typ. 20 A for 75 ms typ. 20 A for 75 ms Not permissible	typ. 20 A for 180 ms typ. 20 A for 80 ms Not permissible	typ. 20 A for 500 ms typ. 20 A for 500 ms Yes, 2

Continued on page 4/5.

1) SIPLUS module 6AG1 307-1EA80-2AA0 for enhanced temperature range -25 to +60 °C and use under medium load (e.g. chlorine/sulfur atmosphere). Conformity with EN 50155 available soon (electrical equipment on track vehicles).

SITOP power · Standard 24 V

Single-phase and two-phase

Output current 5 A

Power supply, type	5 A	5 A	5 A
Order No.	6EP1 333-3BA00	6EP1 333-2BA00	6EP1 333-2AA00
Efficiency			
Efficiency at $V_{out\ rated}$, $I_{out\ rated}$	Approx. 87 %	Approx. 87 %	Approx. 87 %
Power loss at $V_{out\ rated}$, $I_{out\ rated}$	Approx. 18 W	Approx. 18 W	Approx. 18 W
Control			
Dyn. mains compensation ($V_{in\ rated} \pm 15\%$)	Approx. 0.1%	Approx. $\pm 0.3\%$ V_{out}	Approx. $\pm 0.3\%$ V_{out}
Dyn. load compensation (I_{out} : 50/100/50 %)	Approx. $+3\%$ V_{out}	$\pm 2.5\%$ V_{out}	$\pm 2.5\%$ V_{out}
Settling time			
• Load step from 50 to 100 %	< 5 ms (typ. 2 ms)	typ. 0.2 ms	typ. 0.2 ms
• Load step from 100 to 50 %	< 5 ms (typ. 2 ms)	typ. 0.2 ms	typ. 0.2 ms
Protection and monitoring			
Output overvoltage protection	< 35 V	Yes, acc. to EN 60950	Yes, acc. to EN 60950
Current limitation	typ. 5.5 A	typ. 5.5 to 6.5 A	typ. 5.5 to 6.5 A
Short-circuit protection	Choice of stabilized current characteristic approx. 5.5 A or latching shutdown	Electronic shutdown, automatic restart	Electronic shutdown, automatic restart
RMS sustained short-circuit current	Approx. 5.5 A	< 17 A	< 17 A
Overload/short-circuit indicator	Yellow LED for "overload", red LED for "latching shutdown"	-	-
Safety			
Galvanic isolation primary/secondary	Yes, SELV output voltage V_{out} acc. to EN 60950 and EN 50178	Yes, SELV output voltage V_{out} acc. to EN 60950	Yes, SELV output voltage V_{out} acc. to EN 60950
Protective class	Class I	Class I	Class I
Discharge current	< 3.5 mA (typ. 0.25 mA)	< 3.5 mA (typ. 0.4 mA)	< 3.5 mA (typ. 0.4 mA)
TÜV test	Yes	Yes; CB scheme	Yes; CB scheme
CE marking	Yes	Yes	Yes
UL/cUL (CSA) approval	Yes, cULus listed (UL 508, CSA 22.2 No. 14-M91), File E197259	Yes, UL listed (UL 508) File E143289, CSA (CSA 22.2 No. 14-95)	Yes, UL listed (UL 508) File E143289, CSA (CSA 22.2 No. 14-95)
FM approval	-	-	-
Appr. for use in marine vessels	-	-	-
Degree of protection (EN 60529)	IP20	IP20	IP20
EMC			
Interference emission	EN 55022 Class B	EN 55022 Class B	EN 55022 Class B
Line harmonics limitation	EN 61000-3-2	EN 61000-3-2	-
Interference immunity	EN 61000-6-2	EN 61000-6-2	EN 61000-6-2
Operating specifications			
Ambient temperature range	0 to +60 °C with natural convection	0 to +60 °C with natural convection	0 to +60 °C with natural convection
Transportation and storage temperature range	-25 to +85 °C	-25 to +85 °C	-25 to +85 °C
Humidity rating	Climatic class 3K3 acc. to EN 60721, no condensation	Climatic class 3K3 acc. to EN 60721, no condensation	Climatic class 3K3 acc. to EN 60721, no condensation
Mechanical specifications			
Connections			
• Mains input L, N, PE	One screw-type terminal each for 0.2 to 2.5 mm ² single-core/finely stranded	One screw-type terminal each for 0.5 to 2.5 mm ² single-core/finely stranded	One screw-type terminal each for 0.5 to 2.5 mm ² single-core/finely stranded
• Output L+	2 screw-type terminals for 0.2 to 2.5 mm ²	1 screw-type terminal for 0.5 to 2.5 mm ²	1 screw-type terminal for 0.5 to 2.5 mm ²
• Output M	2 screw-type terminals for 0.2 to 2.5 mm ²	2 screw-type terminals for 0.5 to 2.5 mm ²	2 screw-type terminals for 0.5 to 2.5 mm ²
Dimensions (W x H x D) in mm	70 x 125 x 125	75 x 125 x 125	75 x 125 x 125
Weight approx.	1.2 kg	0.75 kg	0.57 kg
Mounting	Snap-mounting on DIN rail EN 50022-35x15/7.5	Snap-mounting on DIN rail EN 50022-35x15/7.5	Snap-mounting on DIN rail EN 50022-35x15/7.5
Accessories	Buffer module (6EP1961-3BA00) Signalling module (6EP1961-3BA10) Redundancy module (6EP1961-3BA20)	-	-

SITOP power · Standard 24 V Single-phase and two-phase

Output current 5 A

5 A	5 A	5 A	5 A
6ES7 307-1EA00-0AA0	6EP1 333-1SL11	6ES7 307-1EA80-0AA0	6EP1 333-1AL12
Approx. 87 % Approx. 18 W	Approx. 87 % Approx. 18 W	Approx. 84 % Approx. 23 W	Approx. 88 % Approx. 17 W
± 0.3 % V _{out}	± 0.3 % V _{out}	± 0.3 % V _{out}	± 0.3 % V _{out}
± 2.5 % V _{out}	± 2.5 % V _{out}	± 3 % V _{out}	± 0.5 % V _{out}
typ. 0.1 ms	typ. 0.1 ms	< 5 ms (typ. 0.2 ms)	< 5 ms (typ. 0.1 ms)
typ. 0.1 ms	typ. 0.1 ms	< 5 ms (typ. 0.2 ms)	< 5 ms (typ. 0.1 ms)
Additional control loop, shut-down at approx. 30 V, automatic restart 5.5 to 6.5 A	Additional control loop, shut-down at approx. 30 V, automatic restart 5.5 to 6.5 A	Additional control loop, shut-down at approx. 30 V, automatic restart 5.5 to 6.5 A	Additional control loop, shut-down at approx. 33 V, automatic restart 5.5 to 6.5 A
Electronic shutdown, automatic restart	Electronic shutdown, automatic restart	Electronic shutdown, automatic restart	Electronic shutdown, automatic restart
< 9 A -	< 9 A -	< 5 A -	< 5 A -
Yes, SELV output voltage V _{out} acc. to EN 60950 and EN 50178	Yes, SELV output voltage V _{out} acc. to EN 60950 and EN 50178	Yes, SELV output voltage V _{out} acc. to EN 60950 and EN 50178, clearance and creepage distances > 8 mm	Yes, SELV output voltage V _{out} acc. to EN 60950 and EN 50178
Class I < 3.5 mA (typ. 0.3 mA)	Class I < 3.5 mA (typ. 0.3 mA)	Class I < 3.5 mA (typ. 0.3 mA)	Class I < 3.5 mA (typ. 0.26 mA)
Yes Yes Yes, UL listed (UL 508) File E143289, CSA (CSA 22.2 No. 14-95)	Yes Yes Yes, UL listed (UL 508) File E143289, CSA (CSA 22.2 No. 14-95)	Yes Yes Yes, UL listed (UL 508) File E143289, CSA (CSA 22.2 No. 14-95)	Yes Yes Yes, cULus listed (UL 508, CSA 22.2 No. 14-M91), File E197259
Yes, Class I Div. 2 Group A, B, C, D, T 4 in the S7-300 system IP20	Yes, Class I Div. 2 Group A, B, C, D, T 4 in the S7-300 system IP20	- Yes, GL, LRS IP20	- - IP20
EN 55022 Class B EN 61000-3-2 EN 61000-6-2	EN 55022 Class B EN 61000-3-2 EN 61000-6-2	EN 55011 Class A - EN 61000-6-2	EN 55022 Class B - EN 61000-6-2
0 to +60 °C with natural convection -40 to +85 °C	0 to +60 °C with natural convection -40 to +85 °C	-40 to +70 °C with natural convection -40 to +85 °C	0 to +60 °C with natural convection -25 to +85 °C
Climatic class 3K3 acc. to EN 60721, no condensation	Climatic class 3K3 acc. to EN 60721, no condensation	Climatic class 3K5 acc. to EN 60721, brief condensation permissible	Climatic class 3K3 acc. to EN 60721, no condensation
One screw-type terminal each for 0.5 to 2.5 mm ² single-core/finely stranded 3 screw-type terminals for 0.5 to 2.5 mm ² 3 screw-type terminals for 0.5 to 2.5 mm ²	One screw-type terminal each for 0.5 to 2.5 mm ² single-core/finely stranded 3 screw-type terminals for 0.5 to 2.5 mm ² 3 screw-type terminals for 0.5 to 2.5 mm ²	One screw-type terminal each for 0.5 to 2.5 mm ² single-core/finely stranded 3 screw-type terminals for 0.5 to 2.5 mm ² 3 screw-type terminals for 0.5 to 2.5 mm ²	One screw-type terminal each for 0.5 to 2.5 mm ² single-core/finely stranded 3 screw-type terminals for 0.5 to 2.5 mm ² 3 screw-type terminals for 0.5 to 2.5 mm ²
80 x 125 x 120 0.74 kg Snap-mounting on S7 rail	80 x 125 x 135 0.74 kg Snap-mounting on DIN rail EN 50022-35x15	80 x 125 x 120 0.57 kg Snap-mounting on S7 rail	160 x 130 x 60 0.6 kg Snap-mounting on DIN rail EN 50022-35x15/7.5
Mounting adapter for DIN rail and connecting comb	Mounting adapter for DIN rail and connecting comb	Mounting adapter for DIN rail and connecting comb	Mounting bracket

4

SITOP power · Standard 24 V

Single-phase and two-phase

Notes

4



SITOP power · Standard 24 V Single-phase and two-phase

5



Output current 10 A

- 5/2 SITOP modular
- 5/2 The proven types
- 5/3 The IP65 version
- 5/3 The S7-300 type
- 5/3 The flat design
- 5/3 The universal type



SITOP power · Standard 24 V

Single-phase and two-phase

Output current 10 A

Overview

SITOP modular



The proven types



Application

The modular power supply unit with single-phase and two-phase wide-range inputs for global use in many different fields of application; expansion of functions possible using add-on modules.

The tried and tested power supply unit with selectable input voltage range for supplying all standard applications in automation engineering; 6EP1334-2AA00 without limitation of input current harmonics.

Technical specifications

Power supply, type	10 A	10 A	10 A
Order No.	6EP1 334-3BA00	6EP1 334-2BA00	6EP1 334-2AA00
Input	Single and two-phase AC	Single-phase AC	Single-phase AC
Rated voltage $V_{in \text{ rated}}$	120/230 to 500 V AC Settable via selector switch on device	120/230 V AC Settable using wire jumper	120/230 V AC Settable using wire jumper
Voltage range	85 to 132/176 to 550 V AC	85 to 132/187 to 264 V AC	85 to 132/187 to 264 V AC
Overvoltage strength	1300 V_{peak} , 1.3 ms	$2.3 \times V_{in \text{ rated}}$, 1.3 ms	$2.3 \times V_{in \text{ rated}}$, 1.3 ms
Mains buffering at $I_{out \text{ rated}}$	> 25 ms at $V_{in} = 120/230 \text{ V}$	> 10 ms at $V_{in} = 93/187 \text{ V}$	> 20 ms at $V_{in} = 93/187 \text{ V}$
Rated line frequency; range	50/60 Hz; 47 to 63 Hz	50/60 Hz; 47 to 63 Hz	50/60 Hz; 47 to 63 Hz
Rated current $I_{in \text{ rated}}$	4.4 / 2.4 to 1.1 A	5.5 / 2.1 A	5.5 / 3.2 A
Inrush current limitation (+25 °C)	< 35 A	< 65 A, typ. 3 ms	< 65 A, typ. 3 ms
I^2t	< 4.0 A ² s	< 3.3 A ² s	< 3.3 A ² s
Integrated line-side fuse	T 6.3 A (not accessible)	T 6.3 A/250 V (not accessible)	T 6.3 A/250 V (not accessible)
Recommended circuit-breaker (IEC 898) in mains supply line	From 6 A (10 A) Characteristic C (B); with two-phase operation: circuit-breaker with two-pole connection or motor circuit-breaker 3RV1021-1EA10	From 10 A, Characteristic C	From 10 A, Characteristic C
Output	Stabilized, floating direct voltage	Stabilized, floating direct voltage	Stabilized, floating direct voltage
Rated voltage $V_{out \text{ rated}}$	24 V DC	24 V DC	24 V DC
Total tolerance	± 3 %	± 3 %	± 3 %
• Stat. mains compensation	Approx. 0.1 %	Approx. 0.2 %	Approx. 0.2 %
• Stat. load compensation	Approx. 0.1 %	Approx. 1 %	Approx. 1 %
Residual ripple (clock frequency: approx. 50 kHz)	< 50 mV _{pp} (typ. 10 mV _{pp})	< 150 mV _{pp}	< 150 mV _{pp}
Spikes (bandwidth: 20 MHz)	< 200 mV _{pp} (typ. 20 mV _{pp})	< 240 mV _{pp}	< 240 mV _{pp}
Setting range	24 to 28.8 V (max. 240 W)	22.8 to 28.8 V	22.8 to 28.8 V
Status display	Green LED for 24 V O.K.	Green LED for 24 V O.K.	Green LED for 24 V O.K.
Power ON/OFF behavior	Overshoot of V_{out} approx. 3%	No overshoot of V_{out} (soft start)	No overshoot of V_{out} (soft start)
Starting delay/voltage rise	< 1 s / < 50 ms	< 3 s / typ. 80 ms	< 3 s / typ. 80 ms
Rated current $I_{out \text{ rated}}$	10 A	10 A	10 A
Current range			
• Up to +45 °C	0 to 10 A	0 to 12 A	0 to 12 A
• Up to +60 °C	0 to 10 A	0 to 10 A	0 to 10 A
Dyn. V/I with			
• Starting on short circuit	Approx. 12 A constant current	typ. 38 A for 200 ms	typ. 38 A for 200 ms
• Short-circuit in operation	typ. 30 A for 25 ms		
Parallel connection for increased output	Yes, 2 (selectable current characteristic)	Yes, 2	Yes, 2

Continued on page 5/4.

SITOP power · Standard 24 V Single-phase and two-phase

Output current 10 A

The IP65 version



Power supply unit with IP65 degree of protection, design and functionality optimally matched to ET 200X distributed I/O devices. When using without ET 200X, the connector seal accessory is required.

The S7-300 type



The proven power supply in the SIMATIC S7-300 design; alternatively with PS-CPU connecting comb for snap-mounting on S7 busbar or without connecting comb for snap-mounting on DIN rail EN 50022-35x15 via mounting adapter.

The flat design



The flat design which is of great advantage where only low mounting depths are available, e.g. for use with distributed I/O, in machine benches or alcoves; design matched to SIMATIC ET 200B.

The universal type



The universal power supply unit for all supply networks, with a wide-range input from 93 V to 264 V AC and 110 V to 350 V DC for supply from all typical networks.

5

10 A

6EP1 334-2CA00

Single-phase AC
120/230 V AC
Settable using wire jumper
93 to 132/187 to 264 V AC

$2.3 \times V_{in \text{ rated}}, 1.3 \text{ ms}$
> 20 ms at $V_{in} = 93/187 \text{ V}$
50/60 Hz, 47 to 63 Hz
4.3/2.6 A
< 65 A, < 3 ms
< 2.5 A²s
T 6.3 A/250 V (not accessible)
From 16 A, Characteristic C

10 A

6ES7 307-1KA01-0AA0 / 6EP1334-1SL12

Single-phase AC
120/230 V AC
Settable via selector switch on device
85 to 132/170 to 264 V AC

$2.3 \times V_{in \text{ rated}}, 1.3 \text{ ms}$
> 20 ms at $V_{in} = 93/187 \text{ V}$
50/60 Hz; 47 to 63 Hz
4.1/1.8 A
< 55 A, < 3 ms
< 3.3 A²s
T 6.3 A/250 V (not accessible)
From 10 A, Characteristic C

10 A

6EP1 334-1AL12

Single-phase AC
120/230 V AC
Settable via selector switch on device
85 to 132/170 to 264 V AC

$2.3 \times V_{in \text{ rated}}, 1.3 \text{ ms}$
> 20 ms at $V_{in} = 93/187 \text{ V}$
50/60 Hz; 47 to 63 Hz
4/2.5 A
< 65 A, < 3 ms
< 3.3 A²s
T 6.3 A/250 V (not accessible)
From 10 A, Characteristic C

10 A

6EP1 334-1SH01

Single-phase AC
120 to 230 V AC
wide-range input
93 to 264 V AC or 110 to 350 V DC

$2.3 \times V_{in \text{ rated}}, 1.3 \text{ ms}$
> 20 ms at $V_{in} = 93/187 \text{ V}$
0/50/60 Hz; 47 to 63 Hz
2.5 to 1.3 A
< 20 A, < 3 ms
< 1.5 A²s
T 6.3 A (not accessible)
From 16 A, Characteristic C

Stabilized, floating direct voltage
24 V DC

± 3 %
Approx. 0.2 %
Approx. 1 %

< 150 mV_{pp}

< 240 mV_{pp}

22.8 to 25.2 V
Green LED for 24 V O.K.
No overshoot of V_{out}
(soft start)

< 3 s/typ. 80 ms

10 A

0 to 10 A (up to +40 °C)
0 to 8 A (up to +55 °C)

typ. 38 A for 200 ms
Yes, 2

Stabilized, floating direct voltage
24 V DC

± 3 %
Approx. 0.1 %
Approx. 0.5 %

< 150 mV_{pp} (typ. 40 mV_{pp})

< 240 mV_{pp} (typ. 100 mV_{pp})

-
Green LED for 24 V O.K.
No overshoot of V_{out}
(soft start)

< 1.5 s/typ. 80 ms

10 A

0 to 10 A
0 to 10 A

typ. 35 A for 80 ms
typ. 35 A for 150 ms
Not permissible

Stabilized, floating direct voltage
24 V DC

± 1 %
Approx. 0.1 %
Approx. 0.5 %

< 150 mV_{pp} (typ. 50 mV_{pp})

< 240 mV_{pp} (typ. 200 mV_{pp})

22 to 29 V
Green LED for 24 V O.K.
No overshoot of V_{out}
(soft start)

< 2 s/typ. 40 ms

10 A

0 to 10 A
0 to 10 A

typ. 35 A for 700 ms
typ. 35 A for 700 ms
Yes, 2

Stabilized, floating direct voltage
24 V DC

± 1 %
< ± 0.1 %
< ± 0.2 %

< 100 mV_{pp}

< 100 mV_{pp}

-
Green LED for 24 V O.K.
No overshoot of V_{out}
(soft start)

< 3 s/typ. 100 ms

10 A

0 to 10 A
0 to 10 A

Approx. 11 A constant current
Approx. 11 A constant current
Yes, 2

Continued on page 5/5.

SITOP power · Standard 24 V

Single-phase and two-phase

Output current 10 A

Power supply, type	10 A	10 A	10 A
Order No.	6EP1 334-3BA00	6EP1 334-2BA00	6EP1 334-2AA00
Efficiency			
Efficiency at V_{out} rated, I_{out} rated	Approx. 87 %	Approx. 89 %	Approx. 89 %
Power loss at V_{out} rated, I_{out} rated	Approx. 36 W	Approx. 30 W	Approx. 30 W
Control			
Dyn. mains compensation (V_{in} rated \pm 15 %)	Approx. 0.1 %	Approx. \pm 0.3 % V_{out}	Approx. \pm 0.3 % V_{out}
Dyn. load compensation (I_{out} : 50/100/50 %)	Approx. +3 % V_{out}	\pm 5 % V_{out}	\pm 5 % V_{out}
Settling time			
• Load step from 50 to 100 %	< 5 ms (typ. 2 ms)	typ. 0.2 ms	typ. 0.2 ms
• Load step from 100 to 50 %	< 5 ms (typ. 2 ms)	typ. 0.2 ms	typ. 0.2 ms
Protection and monitoring			
Output overvoltage protection	< 35 V	Yes, acc. to EN 60950	Yes, acc. to EN 60950
Current limitation	typ. 12 A	typ. 13 to 15 A	typ. 13 to 15 A
Short-circuit protection	Choice of stabilized current characteristic approx. 12 A or latching shutdown	Electronic shutdown, automatic restart	Electronic shutdown, automatic restart
RMS sustained short-circuit current	Approx. 12 A	< 21 A	< 21 A
Overload/short-circuit indicator	Yellow LED for "overload", red LED for "latching shutdown"	-	-
Safety			
Galvanic isolation primary/secondary	Yes, SELV output voltage V_{out} acc. to EN 60950 and EN 50178	Yes, SELV output voltage V_{out} acc. to EN 60950	Yes, SELV output voltage V_{out} acc. to EN 60950
Protective class	Class I	Class I	Class I
Discharge current	< 3.5 mA (typ. 0.32 mA)	< 3.5 mA (typ. 0.4 mA)	< 3.5 mA (typ. 0.4 mA)
TÜV test	Yes	Yes; CB scheme	Yes; CB scheme
CE marking	Yes	Yes	Yes
UL/cUL (CSA) approval	Yes, cULus listed (UL 508, CSA 22.2 No. 14-M91) File E197259	Yes, UL listed (UL 508) File E143289, CSA (CSA 22.2 No. 14-95)	Yes, UL listed (UL 508) File E143289, CSA (CSA 22.2 No. 14-95)
FM approval	-	-	-
Appr. for use in marine vessels	-	-	-
Degree of protection (EN 60529)	IP20	IP20	IP20
EMC			
Interference emission	EN 55022 Class B	EN 55022 Class B	EN 55022 Class B
Line harmonics limitation	EN 61000-3-2	EN 61000-3-2	-
Interference immunity	EN 61000-6-2	EN 61000-6-2	EN 61000-6-2
Operating specifications			
Ambient temperature range	0 to +60 °C with natural convection	0 to +60 °C with natural convection	0 to +60 °C with natural convection
Transportation and storage temperature range	-25 to +85 °C	-25 to +85 °C	-25 to +85 °C
Humidity rating	Climatic class 3K3 acc. to EN 60721, no condensation	Climatic class 3K3 acc. to EN 60721, no condensation	Climatic class 3K3 acc. to EN 60721, no condensation
Mechanical specifications			
Connections			
• Mains input L, N, PE	One screw-type terminal each for 0.2 to 2.5 mm ² single-core/finely stranded	One screw-type terminal each for 0.5 to 2.5 mm ² single-core/finely stranded	One screw-type terminal each for 0.5 to 2.5 mm ² single-core/finely stranded
• Output L+	2 screw-type terminals for 0.2 to 2.5 mm ²	1 screw-type terminal for 0.5 to 2.5 mm ²	1 screw-type terminal for 0.5 to 2.5 mm ²
• Output M	2 screw-type terminals for 0.2 to 2.5 mm ²	2 screw-type terminals for 0.5 to 2.5 mm ²	2 screw-type terminals for 0.5 to 2.5 mm ²
Dimensions (W x H x D) in mm	90 x 125 x 125	100 x 125 x 135	100 x 125 x 135
Weight approx.	1.4 kg	1.08 kg	0.78 kg
Mounting	Snap-mounting on DIN rail EN 50022-35x15/7.5	Snap-mounting on DIN rail EN 50022-35x15/7.5	Snap-mounting on DIN rail EN 50022-35x15/7.5
Accessories	Buffer module (6EP1961-3BA00) Signalling module (6EP1961-3BA10) Redundancy module (6EP1961-3BA20)	-	-

SITOP power · Standard 24 V Single-phase and two-phase

Output current 10 A

10 A	10 A	10 A	10 A
6EP1 334-2CA00	6ES7 307-1KA01-0AA0 / 6EP1334-1SL12	6EP1 334-1AL12	6EP1 334-1SH01
Approx. 87 % Approx. 36 W	Approx. 87 % Approx. 34 W	Approx. 89 % Approx. 30 W	Approx. 85 % Approx. 42 W
± 0.3 % V _{out}	± 0.3 % V _{out}	± 0.3 % V _{out}	± 0.3 % V _{out}
± 5 % V _{out}	± 2.5 % V _{out}	± 0.6 % V _{out}	± 1.5 % V _{out}
typ. 0.2 ms typ. 0.2 ms	< 5 ms < 5 ms	< 5 ms (typ. 0.1 ms) < 5 ms (typ. 0.2 ms)	< 20 ms (typ. 10 ms) < 20 ms (typ. 10 ms)
Yes, acc. to EN 60950	Additional control loop, shut-down at approx. 30 V, automatic restart	Additional control loop, shut-down at approx. 33 V, automatic restart	Yes, acc. to EN 60950
typ. 9 to 11 A	11 to 12 A	11 to 13 A	11 to 13 A
Choice of automatic restart or latching shutdown	Electronic shutdown, automatic restart	Electronic shutdown, automatic restart	Stabilized current characteristic down to 0 V
< 21 A Red LED for overtemperature switch-off	< 10 A -	< 10 A -	< 14 A -
Yes, SELV output voltage V _{out} acc. to EN 60950 Class I < 3.5 mA (typ. 0.9 mA)	Yes, SELV output voltage V _{out} acc. to EN 60950 and EN 50178 Class I < 3.5 mA (typ. 0.5 mA)	Yes, SELV output voltage V _{out} acc. to EN 60950 and EN 50178 Class I < 3.5 mA (typ. 0.27 mA)	Yes, SELV output voltage V _{out} acc. to EN 60950 Class I < 3.5 mA
Yes Yes Yes, UL listed (UL 508) File E143289, CSA (CSA 22.2 No. 14-95)	Yes Yes Yes, UL listed (UL 508) File E143289, CSA (CSA 22.2 No. 14-95)	Yes Yes Yes, cULus listed (UL 508, CSA 22.2 No. 14-M91), File E197259	Yes Yes Yes, cULus listed (UL 508, CSA 22.2 No. 14-M91), File E143289
- - IP65	Yes, Class I Div. 2, A, B, C, D, T4 in the S7-300 system IP20	- - IP20	- - IP20
EN 55011 Class A - EN 61000-6-2	EN 55022 Class B EN 61000-3-2 EN 61000-6-2	EN 55022 Class B - EN 61000-6-2	EN 55022 Class B EN 61000-3-2 EN 61000-6-2
-25 to +55 °C (power derating above +40 °C) -40 to +70 °C	0 to +60 °C with natural convection -40 to +85 °C	0 to +60 °C with natural convection -25 to +85 °C	0 to +60 °C with natural convection -25 to +85 °C
Climatic class 3K3 acc. to EN 60721, no condensation	Climatic class 3K3 acc. to EN 60721, no condensation	Climatic class 3K3 acc. to EN 60721, no condensation	Climatic class 3K3 acc. to EN 60721, no condensation
Screw-type terminals 0.5 to 2.5 mm ² (PG11 screwed gland) Screw terminals, or connection via expansion interface on the backplane bus of the ET 200X Screw terminals, or connection via expansion interface on the backplane bus of the ET 200X	One screw-type terminal each for 0.5 to 2.5 mm ² single-core/finely stranded 4 screw-type terminals for 0.5 to 2.5 mm ² 4 screw-type terminals for 0.5 to 2.5 mm ²	One screw-type terminal each for 0.5 to 2.5 mm ² single-core/finely stranded 3 screw-type terminals for 0.5 to 2.5 mm ² 3 screw-type terminals for 0.5 to 2.5 mm ²	One screw-type terminal each for 0.5 to 2.5 mm ² single-core/finely stranded 3 screw-type terminals for 0.5 to 2.5 mm ² 3 screw-type terminals for 0.5 to 2.5 mm ²
140 x 270 x 126	120 x 125 x 120 ¹⁾ 120 x 125 x 135 ²⁾	160 x 130 x 60	200 x 125 x 135
1.7 kg Wall mounting, any mounting position	1.1 kg Snap-mounting on S7 rail ¹⁾ Snap-mounting on DIN rail EN 50022-35x15 ²⁾	0.72 kg Snap-mounting on DIN rail EN 50022-35x15/7.5	1.8 kg Snap-mounting on DIN rail EN 50022-35x15 or on S7 rail
IP65 connector seal	Mounting adapter for DIN rail and PS-CPU connecting comb	Mounting bracket	-

1) Order No. 6ES7307-1KA01-0AA0.

2) Order No. 6EP1334-1SL12.

SITOP power · Standard 24 V

Single-phase and two-phase

Notes

5



SITOP power · Standard 24 V Single-phase and two-phase

6



6/2

Output currents 20 A and 40 A

SITOP modular

6/3

The proven type

6/3

The two-phase version



SITOP power · Standard 24 V

Single-phase and two-phase

Output currents 20 A and 40 A

Overview

SITOP modular



SITOP modular



Application

The modular power supply units with single-phase and two-phase inputs for global use in many different fields of application; expansion of functions possible using add-on modules.

Technical specifications

Power supply, type	20 A	40 A
Order No.	6EP1 336-3BA00	6EP1 337-3BA00
Input	Single/two-phase AC	Single/two-phase AC
Rated voltage $V_{in \text{ rated}}$	120/230 V AC Settable using wire jumper on device	120/230 V AC Settable using wire jumper on device
Voltage range	85 to 132/176 to 264 V	85 to 132/176 to 264 V
Overvoltage strength	$2.3 \times V_{in \text{ rated}}$, 1.3 ms	$2.3 \times V_{in \text{ rated}}$, 1.3 ms
Mains buffering at $I_{out \text{ rated}}$	> 20 ms at $V_{in} = 230 \text{ V}$	> 20 ms at $V_{in} = 230 \text{ V}$
Rated line frequency; range	50/60 Hz; 47 to 63 Hz	50/60 Hz; 47 to 63 Hz
Rated current $I_{in \text{ rated}}$	7.7/3.5 A	15/8 A
Inrush current limitation (+25 °C)	< 60 A	< 125 A
I^2t	< 9.9 A ² s	< 26 A ² s
Integrated line-side fuse	Yes	Yes
Recommended circuit-breaker (IEC 898) in mains supply line	10 A Char. C (2-pole coupled with 2-phase operation) or motor circuit-breaker 3RV1421-...	20 A Char. C (2-pole coupled with 2-phase operation) or motor circuit-breaker 3RV1421-...
Output	Stabilized, floating direct voltage	Stabilized, floating direct voltage
Rated voltage $V_{out \text{ rated}}$	24 V DC	24 V DC
Total tolerance	± 3 %	± 3 %
• Stat. mains compensation	Approx. 0.1 %	Approx. 0.1 %
• Stat. load compensation	Approx. 0.1 %	Approx. 0.1 %
Residual ripple (clock frequency: approx. 50 kHz)	< 100 mV _{pp} (typ. 30 mV _{pp})	< 100 mV _{pp} (typ. 60 mV _{pp})
Spikes (bandwidth: 20 MHz)	< 200 mV _{pp} (typ. 60 mV _{pp})	< 200 mV _{pp} (typ. 120 mV _{pp})
Setting range	24 to 28.8 V (max. 480 W)	24 to 28.8 V (max. 960 W)
Status display	Green LED for 24 V O.K.	Green LED for 24 V O.K.
Power ON/OFF behavior	Overshoot of V_{out} approx. 3 %	Overshoot of V_{out} approx. 3 %
Starting delay/voltage rise	< 0.1 s / < 50 ms	< 0.1 s / < 50 ms
Rated current $I_{out \text{ rated}}$	20 A	40 A
Current range		
• Up to +45 °C	0 to 20 A	0 to 40 A ¹⁾
• Up to +60 °C	0 to 20 A	0 to 40 A ¹⁾
Dyn. V/I with		
• Starting on short circuit	Approx. 23 A constant current	Approx. 46 A constant current
• Short-circuit in operation	typ. 60 A for 25 ms	typ. 120 A for 25 ms
Parallel connection for increased output	Yes, 2 (selectable current characteristic)	Yes, 2 (selectable current characteristic)

Continued on page 6/4.

1) Derating in 120 V operation necessary.

The proven type



The two-phase version



The tried and tested power supply unit with selectable input voltage range for supplying all standard applications in automation engineering.

The power supply unit with 2-phase wide-range input for widely changing power supply networks (> 550 V) as well as industrial networks in Canada and the USA.

20 A

6EP1 336-2BA00

Single-phase AC
120/230 V AC
Settable using wire jumper

93 to 132/187 to 264 V AC

$2.3 \times V_{in \text{ rated}}$, 1.3 ms

> 10 ms at $V_{in} = 93/187 \text{ V}$

50/60 Hz, 47 to 63 Hz

8.0/3.3 A

< 81 A

< 8 A²s

T 10 A (not accessible)

Circuit-breaker from 16 A

Characteristic C

Stabilized, floating direct voltage

24 V DC

± 3 %

< 150 mV_{pp}

< 240 mV_{pp}

22.8 to 26.4 V¹⁾

Green LED for 24 V O.K.

No overshoot of V_{out}

(soft start)

< 3 s/typ. 80 ms

20 A

0 to 20 A

0 to 20 A (55 °C)

Approx. 20 A constant current

Approx. 20 A constant current

Yes, 2¹⁾

20 A

6EP1 536-2AA00

Two-phase AC
500 to 600 V 2 AC
wide-range input

420 to 682 V 2 AC

$2.3 \times V_{in \text{ rated}}$, 1.3 ms

6/30 ms at $V_{in} = 420/600 \text{ V}$

50/60 Hz; 47 to 63 Hz

1.82 A (at 420 V)

typ. 25 A

< 1.0 A²s

none

Required: 2-pole coupled circuit-breaker Char. C max. 10 A

or motor circuit-breaker

3RV1021-1DA10, setting 3 A

Stabilized, floating direct voltage

24 V DC

± 3 %

< 150 mV_{pp}

< 240 mV_{pp}

22.8 to 28.8 V²⁾

Green LED for 24 V O.K.

Small overshoot of V_{out} (< 2 V for

max. 500 ms)

-

20 A

0 to 20 A

0 to 20 A

Approx. 25 A constant current

Approx. 28 A constant current

Yes, 2²⁾

Continued on page 6/5.

1) Only permissible with ambient temperature from 0 to 45 °C.

2) Only permissible with ambient temperature from 0 to 50 °C.

SITOP power · Standard 24 V

Single-phase and two-phase

Output currents 20 A and 40 A

Power supply, type	20 A	40 A
Order No.	6EP1 336-3BA00	6EP1 337-3BA00
Efficiency		
Efficiency at $V_{out rated}$, $I_{out rated}$	Approx. 89 %	Approx. 88 %
Power loss at $V_{out rated}$, $I_{out rated}$	Approx. 59 W	Approx. 131 W
Control		
Dyn. mains compensation ($V_{in rated} \pm 15\%$)	< 1 % V_{out}	< 1 % V_{out}
Dyn. load compensation (I_{out} : 50/100/50 %)	Approx. $\pm 2\%$ V_{out}	Approx. $\pm 2\%$ V_{out}
Settling time		
• Load step from 50 to 100 %	< 5 ms (typ. 2 ms)	< 5 ms (typ. 2 ms)
• Load step from 100 to 50 %	< 5 ms (typ. 2 ms)	< 5 ms (typ. 2 ms)
Protection and monitoring		
Output overvoltage protection	< 35 V	< 35 V
Current limitation	typ. 23 A	typ. 46 A
Short-circuit protection	Choice of stabilized current characteristic approx. 23 A or latching shutdown	Choice of stabilized current characteristic approx. 46 A or latching shutdown
RMS sustained short-circuit current	Approx. 23 A	Approx. 46 A
Overload/short-circuit indicator	Yellow LED for "overload", red LED for "latching shutdown"	Yellow LED for "overload", red LED for "latching shutdown"
Safety		
Galvanic isolation primary/secondary	Yes, SELV output voltage V_{out} acc. to EN 60950 and EN 50178	Yes, SELV output voltage V_{out} acc. to EN 60950 and EN 50178
Protective class	Class I	Class I
Discharge current	< 3.5 mA (typ. 0.4 mA)	< 3.5 mA (typ. 0.4 mA)
TÜV test	Yes	Yes
CE marking	Yes	Yes
UL/cUL (CSA) approval	Yes, cULus listed (UL 508, CSA 22.2 No. 14-M91), File E197259	Yes, cULus listed (UL 508, CSA 22.2 No. 14-M91), File E197259
FM approval	-	-
Appr. for use in marine vessels	-	-
Degree of protection (EN 60529)	IP20	IP20
EMC		
Interference emission	EN 55022 Class B	EN 55022 Class B
Line harmonics limitation	EN 61000-3-2	-
Interference immunity	EN 61000-6-2	EN 61000-6-2
Operating specifications		
Ambient temperature range	0 to +60 °C with natural convection	0 to +60 °C with natural convection
Transportation and storage temperature range	-25 to +85 °C	-25 to +85 °C
Humidity rating	Climatic class 3K3 acc. to EN 60721, no condensation	Climatic class 3K3 acc. to EN 60721, no condensation
Mechanical specifications		
Connections		
• Mains input L, N, PE	One screw-type terminal each for 0.2 to 4 mm ² single-core/finely stranded	One screw-type terminal each for 0.2 to 4 mm ² single-core/finely stranded
• Output L+	2 screw-type terminals for 0.5 to 4 mm ²	2 screw-type terminals for 0.5 to 10 mm ²
• Output M	2 screw-type terminals for 0.5 to 4 mm ²	2 screw-type terminals for 0.5 to 10 mm ²
Dimensions (W x H x D) in mm	160 x 125 x 125	240 x 125 x 125
Weight approx.	2.2 kg	2.9 kg
Mounting	Snap-mounting on DIN rail EN 50022-35x15/7.5	Snap-mounting on DIN rail EN 50022-35x15/7.5
Accessories		
	Buffer module (6EP1961-3BA00)	Buffer module (6EP1961-3BA00)
	Signalling module (6EP1961-3BA10)	Signalling module (6EP1961-3BA10)
	Redundancy module (6EP1961-3BA20)	Redundancy module (6EP1961-3BA20)

SITOP power · Standard 24 V Single-phase and two-phase

Output currents 20 A and 40 A

20 A

6EP1 336-2BA00

Approx. 87 %
Approx. 72 W

Approx. $\pm 0.3\%$ V_{out}
 $\pm 1\%$ V_{out}

V_{out} not outside tolerance
 V_{out} not outside tolerance

Yes, acc. to EN 60950
typ. 22 A

Stabilized current characteristic
down to 0 V

< 22 A

-

Yes, SELV output voltage V_{out}
acc. to EN 60950
Class I
< 3.5 mA

Yes
Yes
Yes, UL listed (UL 508)
File E143289, CSA (CSA 22.2
No. 14-95)

-

-

IP20

EN 55022 Class B
EN 61000-3-2
EN 61000-6-2

0 to +55 °C with natural
convection
-25 to +85 °C

Climatic class 3K3 acc. to
EN 60721, no condensation

One screw-type terminal each
for 0.5 to 2.5 mm² single-
core/finely stranded
1 screw-type terminal for
0.33 to 10 mm²
2 screw-type terminals for
0.33 to 10 mm²

280 x 125 x 92
2.4 kg
Snap-mounting on DIN rail
EN 50022-35x15/7.5

Mounting bracket 90°
(6EP1971-2BA00)

20 A

6EP1 536-2AA00

Approx. 89 %
Approx. 60 W

< 1 % V_{out}
-4 %, +2 % V_{out}

< 3 ms
< 3 ms

Yes, acc. to EN 60950
typ. 21 to 26 A

Stabilized current characteristic
approx. 28 A

Approx. 28 A

-

Yes, SELV output voltage V_{out}
acc. to EN 60950
Class I
< 0.78 mA (550 V/60 Hz)

Yes
Yes
Yes, UL listed (UL 508)
File E143289, CSA (CSA 22.2
No. 14-95)

-

-

IP20

EN 55011 Class A
-
EN 61000-6-2

0 to +60 °C with natural
convection
-25 to +85 °C

Climatic class 3K3 acc. to
EN 60721, no condensation

One screw-type terminal each
for 0.5 to 2.5 mm² single-
core/finely stranded
1 screw-type terminal for
0.33 to 10 mm²
2 screw-type terminals for
0.33 to 10 mm²

280 x 180 x 92
3.3 kg
Snap-mounting on DIN rail
EN 50022-35x15/7.5

Mounting bracket 90°
(6EP1971-2BA00)

6

SITOP power · Standard 24 V

Single-phase and two-phase

Notes

6

SITOP power · Standard 24 V Three-phase



Output currents 5 A to 40 A

- 7/2 SITOP modular
- 7/2 ■ 5 A and 10 A
- 7/3 ■ 20 A and 40 A
- 7/6 The proven types
- 7/6 ■ 10 A and 20 A
- 7/7 ■ 30 A and 40 A



SITOP power · Standard 24 V Three-phase

Output currents 5 A to 40 A

Overview

SITOP modular



SITOP modular



Application

The modular power supply units with wide-range input for two-phase connection to three-phase power supply networks; for global use in many different fields of application; expansion of functions possible using add-on modules.

Technical specifications

Power supply, type	5 A	10 A
Order No.	6EP1 333-3BA00	6EP1 334-3BA00
Input	Two-phase AC 120/230 to 500 V AC Settable via selector switch on device	Two-phase AC 120/230 to 500 V AC Settable via selector switch on device
Rated voltage $V_{in \text{ rated}}$	85 to 132/176 to 550 V AC	85 to 132/176 to 550 V AC
Voltage range	85 to 132/176 to 550 V AC	85 to 132/176 to 550 V AC
Overvoltage strength	1300 V_{peak} , 1.3 ms	1300 V_{peak} , 1.3 ms
Mains buffering at $I_{out \text{ rated}}$	> 25 ms at $V_{in} = 120/230$ V	> 25 ms at $V_{in} = 120/230$ V
Rated line frequency; range	50/60 Hz; 47 to 63 Hz	50/60 Hz; 47 to 63 Hz
Rated current $I_{in \text{ rated}}$	2.2/1.2 to 0.61 A	4.4/2.4 to 1.1 A
Inrush current limitation (+25 °C)	< 35 A	< 35 A
I^2t	< 1.7 A ² s	< 4.0 A ² s
Integrated line-side fuse	T 3, 15 A	T 6.3 A
Required fuse protection in mains supply line	Circuit-breaker 6 A (10 A) Characteristic C (B), 2-pole coupled, or motor circuit-breaker 3RV1021-...	Circuit-breaker 6 A (10 A) Characteristic C (B), 2-pole coupled, or motor circuit-breaker 3RV1021-...
Output	Stabilized, floating direct voltage	Stabilized, floating direct voltage
Rated voltage $V_{out \text{ rated}}$	24 V DC	24 V DC
Total tolerance	± 3 %	± 3 %
• Stat. mains compensation	Approx. 0.1 %	Approx. 0.1 %
• Stat. load compensation	Approx. 0.1 %	Approx. 0.1 %
Residual ripple (clock frequency: approx. 50 kHz)	< 50 mV _{pp} (typ. 10 mV _{pp})	< 50 mV _{pp} (typ. 10 mV _{pp})
Spikes (bandwidth: 20 MHz)	< 200 mV _{pp} (typ. 20 mV _{pp})	< 200 mV _{pp} (typ. 20 mV _{pp})
Setting range	24 to 28.8 V (max. 120 W)	24 to 28.8 V (max. 240 W)
Status display	Green LED for 24 V O.K.	Green LED for 24 V O.K.
Power ON/OFF behavior	Overshoot of V_{out} approx. 3 %	Overshoot of V_{out} approx. 3 %
Starting delay/voltage rise	< 1 s / < 50 ms	< 1 s / < 50 ms
Rated current $I_{out \text{ rated}}$	5 A	10 A
Current range	0 to 5 A	0 to 10 A
• Up to +45 °C	0 to 5 A	0 to 10 A
• Up to +60 °C	0 to 5 A	0 to 10 A
Dyn. V/I with		
• Starting on short circuit	Approx. 5.5 A constant current	Approx. 12 A constant current
• Short-circuit in operation	typ. 15 A for 25 ms	typ. 30 A for 25 ms
Parallel connection for increased output	Yes, 2 (selectable current characteristic)	Yes, 2 (selectable current characteristic)

Continued on page 7/4.

SITOP power · Standard 24 V Three-phase

Output currents 5 A to 40 A

SITOP modular



SITOP modular



The modular power supply units with three-phase wide-range input for global use in many different fields of application; expansion of functions possible using add-on modules.

20 A

6EP1 436-3BA00

Three-phase AC
400 to 500 V 3 AC
wide-range input

320 to 550 V
(startup from $V_{in} > 340$)

$2.3 \times V_{in \text{ rated}}$, 1.3 ms

> 6 ms at $V_{in} = 400$ V

50/60 Hz; 47 to 63 Hz

1.1 A ($V_{in} = 400$ V)

< 35 A

< 0.7 A²s

None

3-pole coupled circuit-breaker

6 to 16 A Char. C or motor

circuit-breaker 3RV1021-1DA10,

setting 3 A

Stabilized, floating direct voltage

24 V DC

± 3 %

Approx. ± 0.1 %

Approx. ± 0.2 %

< 100 mV_{pp}

< 200 mV_{pp}

24 to 28.8 V (max. 480 W)

Green LED for 24 V O.K.

No overshoot of V_{out} (soft start)

< 2.5 s / < 500 ms

20 A

0 to 20 A

0 to 20 A

Approx. 23 A constant current

typ. 60 A for 25 ms

Yes, 2 (selectable current

characteristic)

Continued on page 7/5.

40 A

6EP1 437-3BA00

Three-phase AC
400 to 500 V 3 AC
wide-range input

320 to 550 V
(startup from $V_{in} > 340$)

$2.3 \times V_{in \text{ rated}}$, 1.3 ms

> 6 ms at $V_{in} = 400$ V

50/60 Hz; 47 to 63 Hz

2.2 A ($V_{in} = 400$ V)

< 70 A

< 2.8 A²s

None

3-pole coupled circuit-breaker

10 to 16 A Char. C or motor

circuit-breaker 3RV1021-1DA10,

setting 3 A

Stabilized, floating direct voltage

24 V DC

± 3 %

Approx. ± 0.1 %

Approx. ± 0.2 %

< 100 mV_{pp}

< 200 mV_{pp}

24 to 28.8 V (max. 960 W)

Green LED for 24 V O.K.

No overshoot of V_{out} (soft start)

< 2.5 s / < 500 ms

40 A

0 to 40 A

0 to 40 A

Approx. 46 A constant current

typ. 120 A for 25 ms

Yes, 2 (selectable current

characteristic)

SITOP power · Standard 24 V Three-phase

Output currents 5 A to 40 A

Power supply, type	5 A	10 A
Order No.	6EP1 333-3BA00	6EP1 334-3BA00
Efficiency		
Efficiency at $V_{out rated}$, $I_{out rated}$	Approx. 87 %	Approx. 87 %
Power loss at $V_{out rated}$, $I_{out rated}$	Approx. 18 W	Approx. 36 W
Control		
Dyn. mains compensation ($V_{in rated} \pm 15\%$)	Approx. 0.1 %	Approx. 0.1 %
Dyn. load compensation (I_{out} : 50/100/50 %)	Approx. +3 % V_{out}	Approx. +3% V_{out}
Settling time		
• Load step from 50 to 100 %	< 5 ms (typ. 2 ms)	< 5 ms (typ. 2 ms)
• Load step from 100 to 50 %	< 5 ms (typ. 2 ms)	< 5 ms (typ. 2 ms)
Protection and monitoring		
Output overvoltage protection	< 35 V	< 35 V
Current limitation	typ. 5.5 A	typ. 12 A
Short-circuit protection	Choice of stabilized current characteristic approx. 5.5 A or latching shutdown	Choice of stabilized current characteristic approx. 12 A or latching shutdown
RMS sustained short-circuit current	Approx. 5.5 A	Approx. 12 A
Overload/short-circuit indicator	Yellow LED for "overload", red LED for "latching shutdown"	Yellow LED for "overload", red LED for "latching shutdown"
Safety		
Galvanic isolation primary/secondary	Yes, SELV output voltage V_{out} acc. to EN 60950 and EN 50178	Yes, SELV output voltage V_{out} acc. to EN 60950 and EN 50178
Protective class	Class I	Class I
Discharge current	< 3.5 mA (typ. 0.25 mA)	< 3.5 mA (typ. 0.32 mA)
TÜV test	Yes	Yes
CE marking	Yes	Yes
UL/cUL (CSA) approval	Yes, cULus listed (UL 508, CSA 22.2 No. 14-M91), File E197259	Yes, cULus listed (UL 508, CSA 22.2 No. 14-M91), File E197259
FM approval	-	-
Appr. for use in marine vessels	-	-
Degree of protection (EN 60529)	IP20	IP20
EMC		
Interference emission	EN 55022 Class B	EN 55022 Class B
Line harmonics limitation	EN 61000-3-2	EN 61000-3-2
Interference immunity	EN 61000-6-2	EN 61000-6-2
Operating specifications		
Ambient temperature range	0 to +60 °C with natural convection	0 to +60 °C with natural convection
Transportation and storage temperature range	-25 to +85 °C	-25 to +85 °C
Humidity rating	Climatic class 3K3 acc. to EN 60721, no condensation	Climatic class 3K3 acc. to EN 60721, no condensation
Mechanical specifications		
Connections		
• Mains input L1, L2, L3, PE	One screw-type terminal each for 0.2 to 2.5 mm ² single-core/finely stranded	One screw-type terminal each for 0.2 to 2.5 mm ² single-core/finely stranded
• Output L+	2 screw-type terminals for 0.2 to 2.5 mm ²	2 screw-type terminals for 0.2 to 2.5 mm ²
• Output M	2 screw-type terminals for 0.2 to 2.5 mm ²	2 screw-type terminals for 0.2 to 2.5 mm ²
Dimensions (W x H x D) in mm	70 x 125 x 125	90 x 125 x 125
Weight approx.	1.2 kg	1.4 kg
Mounting	Snap-mounting on DIN rail EN 50022-35x15/7.5	Snap-mounting on DIN rail EN 50022-35x15/7.5
Accessories	Buffer module (6EP1961-3BA00) Signalling module (6EP1961-3BA10) Redundancy module (6EP1961-3BA20)	Buffer module (6EP1961-3BA00) Signalling module (6EP1961-3BA10) Redundancy module (6EP1961-3BA20)

SITOP power · Standard 24 V Three-phase

Output currents 5 A to 40 A

20 A

6EP1 436-3BA00

Approx. 90 %
Approx. 53 W

< 1 % V_{out}

Approx. $\pm 2\%$ V_{out}

< 10 ms (typ. 4 ms)
< 10 ms (typ. 4 ms)

< 35 V
typ. 23 A

Choice of stabilized current characteristic approx. 23 A or latching shutdown
Approx. 23 A
Yellow LED for "overload", red LED for "latching shutdown"

Yes, SELV output voltage V_{out} acc. to EN 60950 and EN 50178
Class I
< 3.5 mA

Yes
Yes
Yes, UL listed (UL 508)
File E197259, CSA (CSA 22.2 No. 14-95)

-
-
IP20

EN 55022 Class B
EN 61000-3-2
EN 61000-6-2

0 to +60 °C with natural convection
-25 to +85 °C

Climatic class 3K3 acc. to EN 60721, no condensation

One screw-type terminal each for 0.2 to 4 mm² single-core/finely stranded
2 screw-type terminals for 0.33 to 4 mm²
2 screw-type terminals for 0.33 to 4 mm²

160 x 125 x 125
2 kg
Snap-mounting on DIN rail
EN 50022-35x15/7.5

Buffer module (6EP1961-3BA00)
Signalling module (6EP1961-3BA10)
Redundancy module (6EP1961-3BA20)

40 A

6EP1 437-3BA00

Approx. 90 %
Approx. 106 W

< 1 % V_{out}

Approx. $\pm 2\%$ V_{out}

< 10 ms (typ. 4 ms)
< 10 ms (typ. 4 ms)

< 35 V
typ. 46 A

Choice of stabilized current characteristic approx. 46 A or latching shutdown
Approx. 46 A
Yellow LED for "overload", red LED for "latching shutdown"

Yes, SELV output voltage V_{out} acc. to EN 60950 and EN 50178
Class I
< 3.5 mA

Yes
Yes
Yes, UL listed (UL 508)
File E197259, CSA (CSA 22.2 No. 14-95)

-
-
IP20

EN 55022 Class B
EN 61000-3-2
EN 61000-6-2

0 to +60 °C with natural convection
-25 to +85 °C

Climatic class 3K3 acc. to EN 60721, no condensation

One screw-type terminal each for 0.2 to 4 mm² single-core/finely stranded
2 screw-type terminals for 0.33 to 10 mm²
2 screw-type terminals for 0.33 to 10 mm²

240 x 125 x 125
3.2 kg
Snap-mounting on DIN rail
EN 50022-35x15/7.5

Buffer module (6EP1961-3BA00)
Signalling module (6EP1961-3BA10)
Redundancy module (6EP1961-3BA20)

SITOP power · Standard 24 V Three-phase

Output currents 10 A to 40 A

Overview

The proven types



Application

The tried and tested power supply units with three-phase wide-range input for supplying all standard applications in automation engineering.

Technical specifications

Power supply, type	10 A	20 A
Order No.	6EP1 434-2BA00	6EP1 436-2BA00
Input	Three-phase AC	Three-phase AC
Rated voltage $V_{in \text{ rated}}$	400 to 500 V 3 AC wide-range input	400 to 500 V 3 AC wide-range input
Voltage range	360 to 550 V 3 AC (340 to 360 V for max. 2 s or at max. $0.9 \times I_{out \text{ rated}}$)	360 to 550 V 3 AC (340 to 360 V for max. 2 s or at max. $0.9 \times I_{out \text{ rated}}$)
Overvoltage strength	$2.3 \times V_{in \text{ rated}}$, 1.3 ms	$2.3 \times V_{in \text{ rated}}$, 1.3 ms
Mains buffering at $I_{out \text{ rated}}$	> 6 ms at $V_{in} = 360 \text{ V}$	> 3 ms at $V_{in} = 360 \text{ V}$
Rated line frequency; range	50/60 Hz; 47 to 63 Hz	50/60 Hz; 47 to 63 Hz
Rated current $I_{in \text{ rated}}$	0.65 A (at 400 V)	1.2 A (at 400 V)
Inrush current limitation (+25 °C)	< 25 A	< 25 A
I^2t	< 1.0 A ² s	< 1.0 A ² s
Integrated line-side fuse	none	none
Required fuse protection in mains supply line	3-pole coupled circuit-breaker Char. C up to 25 A (recommendation: 6 A) or motor circuit-breaker 3RV1021-1DA10, setting 3 A	3-pole coupled circuit-breaker Char. C up to 25 A (recommendation: 6 A) or motor circuit-breaker 3RV1021-1DA10, setting 3 A
Output	Stabilized, floating direct voltage	Stabilized, floating direct voltage
Rated voltage $V_{out \text{ rated}}$	24 V DC	24 V DC
Total tolerance	± 3 %	± 3 %
• Stat. mains compensation		
• Stat. load compensation		
Residual ripple (clock frequency: approx. 50 kHz)	< 150 mV _{pp} (typ. 60 mV _{pp})	< 150 mV _{pp} (typ. 60 mV _{pp})
Spikes (bandwidth: 20 MHz)	< 240 mV _{pp} (typ. 120 mV _{pp})	< 240 mV _{pp} (typ. 120 mV _{pp})
Setting range	22.8 to 26.4 V ¹⁾	22.8 to 26.4 V ¹⁾
Status display	Green LED for 24 V O.K.	Green LED for 24 V O.K.
Power ON/OFF behavior	No overshoot of V_{out} (soft start)	No overshoot of V_{out} (soft start)
Starting delay/voltage rise	< 3 s/typ. 40 ms	< 3 s/typ. 40 ms
Rated current $I_{out \text{ rated}}$	10 A	20 A
Current range		
• Up to +45 °C	0 to 10 A	0 to 20 A
• Up to +55 °C	0 to 10 A	0 to 20 A
Dyn. V/I with		
• Starting on short circuit	Constant current approx. 18 A	Constant current approx. 30 A
• Short-circuit in operation	Constant current approx. 18 A	Constant current approx. 30 A
Parallel connection for increased output	Yes, 2 ¹⁾	Yes, 2 ¹⁾

Continued on page 7/8.

1) Only permissible with ambient temperature from 0 °C to 45 °C.

SITOP power · Standard 24 V Three-phase

Output currents 10 A to 40 A

The proven types



The tried and tested power supply units with three-phase wide-range input for supplying all standard applications in automation engineering.

30 A	40 A
6EP1 437-2BA00	6EP1 437-2BA10
Three-phase AC 400 to 500 V 3 AC wide-range input 360 to 550 V 3 AC (340 to 360 V for max. 2 s or at max. 0.9 x I _{out rated})	Three-phase AC 400 to 500 V 3 AC wide-range input 360 to 550 V 3 AC (340 to 360 V for max. 2 s or at max. 0.9 x I _{out rated})
2.3 x V _{in rated} , 1.3 ms > 4.5 ms at V _{in} = 360 V 50/60 Hz; 47 to 63 Hz 1.4 A (at 400 V) < 25 A < 1.0 A ² s none 3-pole coupled circuit-breaker Char. C up to 25 A (recommendation: 6 A) or motor circuit-breaker 3RV1021-1DA10, setting 3 A	2.3 x V _{in rated} , 1.3 ms > 3 ms at V _{in} = 360 V 50/60 Hz; 47 to 63 Hz 1.9 A (at 400 V) < 25 A < 1.0 A ² s none 3-pole coupled circuit-breaker Char. C up to 25 A (recommendation: 6 A) or motor circuit-breaker 3RV1021-1DA10, setting 3 A
Stabilized, floating direct voltage 24 V DC ± 3 %	Stabilized, floating direct voltage 24 V DC ± 3 %
< 150 mV _{pp} (typ. 50 mV _{pp}) < 240 mV _{pp} (typ. 200 mV _{pp}) 22.8 to 26.4 V ¹⁾ Green LED for 24 V O.K. Small overshoot of V _{out} (< 2 V for max. 500 ms)	< 150 mV _{pp} (typ. 50 mV _{pp}) < 240 mV _{pp} (typ. 200 mV _{pp}) 22.8 to 26.4 V ¹⁾ Green LED for 24 V O.K. Small overshoot of V _{out} (< 2 V for max. 500 ms)
< 3 ms/typ. 40 ms 30 A	< 3 ms/typ. 40 ms 40 A
0 to 30 A 0 to 30 A	0 to 40 A 0 to 40 A
Approx. 60 A for 600 ms Approx. 60 A for 600 ms Yes, 2 ¹⁾	Approx. 70 A for 600 ms Approx. 70 A for 600 ms Yes, 2 ¹⁾

Continued on page 7/9.

SITOP power · Standard 24 V

Three-phase

Output currents 10 A to 40 A

Power supply, type	10 A	20 A
Order No.	6EP1 434-2BA00	6EP1 436-2BA00
Efficiency		
Efficiency at $V_{out rated}$, $I_{out rated}$	Approx. 89 %	Approx. 89 %
Power loss at $V_{out rated}$, $I_{out rated}$	Approx. 30 W	Approx. 59 W
Control		
Dyn. mains compensation ($V_{in rated} \pm 15\%$)	< 1 % V_{out}	< 1 % V_{out}
Dyn. load compensation (I_{out} : 50/100/50 %)	$\pm 2\%$ V_{out}	$\pm 2\%$ V_{out}
Settling time		
• Load step from 50 to 100 %	< 2 ms	< 2 ms
• Load step from 100 to 50 %	< 2 ms	< 2 ms
Protection and monitoring		
Output overvoltage protection	Yes, acc. to EN 60950	Yes, acc. to EN 60950
Current limitation	typ. 10.5 to 13 A	typ. 21 to 26 A
Short-circuit protection	Stabilized current characteristic down to 0 V	Stabilized current characteristic down to 0 V
RMS sustained short-circuit current	< 20 A	< 30 A
Overload/short-circuit indicator	-	-
Safety		
Galvanic isolation primary/secondary	Yes, SELV output voltage V_{out} acc. to EN 60950	Yes, SELV output voltage V_{out} acc. to EN 60950
Protective class	Class I	Class I
Discharge current	< 0.35 mA (550 V/60 Hz)	< 0.35 mA (550 V/60 Hz)
TÜV test	Yes; CB scheme	Yes; CB scheme
CE marking	Yes	Yes
UL/cUL (CSA) approval	Yes, cULus listed (UL 508, CSA 22.2 No. 14-M91), File E143289	Yes, cULus listed (UL 508, CSA 22.2 No. 14-M91), File E143289
FM approval	-	-
Appr. for use in marine vessels	-	-
Degree of protection (EN 60529)	IP20	IP20
EMC		
Interference emission	EN 55022 Class B	EN 55022 Class B
Line harmonics limitation	EN 61000-3-2	EN 61000-3-2
Interference immunity	EN 61000-6-2	EN 61000-6-2
Operating specifications		
Ambient temperature range	0 to +55 °C with natural convection	0 to +55 °C with natural convection
Transportation and storage temperature range	-25 to +85 °C	-25 to +85 °C
Humidity rating	Climatic class 3K3 acc. to EN 60721, no condensation	Climatic class 3K3 acc. to EN 60721, no condensation
Mechanical specifications		
Connections		
• Mains input L1, L2, L3, PE	One screw-type terminal each for 0.5 to 2.5 mm ² single- core/finely stranded	One screw-type terminal each for 0.5 to 2.5 mm ² single- core/finely stranded
• Output L+	1 screw-type terminal for 0.33 to 10 mm ²	1 screw-type terminal for 0.33 to 10 mm ²
• Output M	2 screw-type terminals for 0.33 to 10 mm ²	2 screw-type terminals for 0.33 to 10 mm ²
Dimensions (W x H x D) in mm	280 x 125 x 92	280 x 125 x 92
Weight approx.	2 kg	2 kg
Mounting	Snap-mounting on DIN rail EN 50022-35x15/7.5	Snap-mounting on DIN rail EN 50022-35x15/7.5
Accessories	Mounting bracket 90° (6EP1971-2BA00)	Mounting bracket 90° (6EP1971-2BA00)

SITOP power · Standard 24 V Three-phase

Output currents 10 A to 40 A

30 A	40 A
6EP1 437-2BA00	6EP1 437-2BA10
Approx. 90 % Approx. 80 W	Approx. 90 % Approx. 107 W
< 1 % V_{out} -4 %, +2 % V_{out}	< 1 % V_{out} -4 %, +2 % V_{out}
< 3 ms < 3 ms	< 3 ms < 3 ms
Yes, acc. to EN 60950 typ. 31.5 to 39 A	Yes, acc. to EN 60950 typ. 42 to 52 A
Electronic shutdown, automatic restart	Electronic shutdown, automatic restart
< 48 A -	< 62 A -
Yes, SELV output voltage V_{out} acc. to EN 60950 Class I < 0.78 mA (550 V/60 Hz)	Yes, SELV output voltage V_{out} acc. to EN 60950 Class I < 0.78 mA (550 V/60 Hz)
Yes; CB scheme Yes Yes, cULus listed (UL 508, CSA 22.2 No. 14-M91), File E143289	Yes; CB scheme Yes Yes, cULus listed (UL 508, CSA 22.2 No. 14-M91), File E143289
- - IP20	- - IP20
EN 55022 Class B EN 61000-3-2 EN 61000-6-2	EN 55022 Class B EN 61000-3-2 EN 61000-6-2
0 to +55 °C with natural convection -25 to +85 °C	0 to +55 °C with natural convection -25 to +85 °C
Climatic class 3K3 acc. to EN 60721, no condensation	Climatic class 3K3 acc. to EN 60721, no condensation
One screw-type terminal each for 0.5 to 2.5 mm ² single- core/finely stranded 1 screw-type terminal for 0.33 to 10 mm ² 2 screw-type terminals for 0.33 to 10 mm ²	One screw-type terminal each for 0.5 to 2.5 mm ² single- core/finely stranded 1 screw-type terminal for 0.33 to 10 mm ² 2 screw-type terminals for 0.33 to 10 mm ²
280 x 180 x 92 3.6 kg Snap-mounting on DIN rail EN 50022-35x15/7.5	280 x 180 x 92 3.6 kg Snap-mounting on DIN rail EN 50022-35x15/7.5
Mounting bracket 90° (6EP1971-2BA00)	Mounting bracket 90° (6EP1971-2BA00)

7

SITOP power · Standard 24 V

Three-phase

Notes

7



SITOP power · Standard 24 V Additional components

8



- 8/2 SITOP modular signalling module
- 8/2 SITOP modular buffer module
- 8/2 SITOP modular redundancy module
- 8/4 SITOP select diagnosis module
- 8/6 Mounting bracket 90°
- 8/7 Mounting adapter for S7 rail and PS-CPU connecting comb
- 8/7 IP65 connector seals
- 8/7 Circular input connectors and AS-Interface coupling module PG



SITOP power · Standard 24 V

Additional components

Overview

SITOP modular signalling module

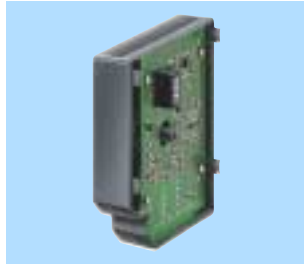

SITOP modular buffer module



SITOP modular redundancy module



Application

Using the signalling module in combination with a stabilized SITOP modular power supply unit, signals can be provided on the operating status of the power supply unit, and remote switching ON/OFF of the unit is possible; automatic contacting with the power supply unit.

With brief interruptions in the power supply, the buffer module in combination with a stabilized SITOP modular power supply unit can buffer the load current without an interruption. The buffer module is wired in parallel with the output of the power supply unit.

The redundancy module serves to decouple two stabilized SITOP modular power supplies in parallel mode. If one power supply fails, the 24 V is safely retained.

Technical specifications

Order No.	6EP1 961-3BA10	6EP1 961-3BA00	6EP1 961-3BA20
Input/output			
Rated input voltage $V_{in \text{ rated}}$	-	Stabilized, floating direct voltage 24 V DC	Stabilized, floating direct voltage 24 V DC
Input voltage range	-	24 to 28.8 V DC	24 to 28.8 V DC
Control input	Non-isolated input for remote ON/OFF switching of the power supply unit	-	-
Rated output voltage $V_{out \text{ rated}}$	-	V_{in} – approx. 1 V	V_{in} – approx. 0.5 V
Rated current $I_{out \text{ rated}}$	-	40 A	20 A (maximum total current 40 A)
Mains buffering	-	100 ms at 40 A up to 800 ms at 5 A load current	-
Buffer time, max.	-	3 s	-
Parallel connection for increased output	-	Yes, 2	-
Protection and monitoring			
Static current limitation	-	typ. 40 A	-
Short-circuit protection	-	Electronic	-
Displays/messages			
Status display	-	Green LED for supply voltage > 20.5 V	Green LED for "Power supply 1 and Power supply 2 OK"
Signals	Floating relay contacts (changeover contacts, rating 6 A/240 V AC) for "Output voltage OK" and "Power supply availability OK"	-	Floating relay contact (changeover contact, rating 6 A/240 V AC) for "Power supply 1 and Power supply 2 OK", switching threshold adjustable from 20 to 25 V

SITOP power · Standard 24 V

Additional components

Technical specifications (continued)

Order No.	6EP1 961-3BA10	6EP1 961-3BA00	6EP1 961-3BA20
Safety			
Galvanic isolation	Yes, SELV acc. to EN 60950 (relay contacts)	Yes, SELV acc. to EN 60950	Yes, SELV acc. to EN 60950 (relay contact)
Protective class	Class I	Class I	Class I
TÜV test	Yes	Yes	Yes
CE marking	Yes	Yes	Yes
UL/cUL (CSA) approval	Yes, UL listed (UL 508) File E197259, CSA (CSA 22.2 No. 14-95)	Yes, UL listed (UL 508) File E197259, CSA (CSA 22.2 No. 14-95)	Yes, cULus listed (UL 508, CSA 22.2 No. 14-M91)
FM approval	-	-	-
Appr. for use in marine vessels	-	-	-
Degree of protection (EN 60529)	IP20	IP20	IP20
EMC			
Interference emission	EN 55022 Class B	EN 55022 Class B	EN 55022 Class B
Interference immunity	EN 61000-6-2	EN 61000-6-2	EN 61000-6-2
Operating specifications			
Ambient temperature range	0 to +60 °C with natural convection	0 to +60 °C with natural convection	0 to +60 °C with natural convection
Transportation and storage temperature range	-25 to +85 °C	-25 to +85 °C	-25 to +85 °C
Humidity rating	Climatic class 3K3 acc. to EN 60721, no condensation	Climatic class 3K3 acc. to EN 60721, no condensation	Climatic class 3K3 acc. to EN 60721, no condensation
Mechanical specifications			
Connections	Screw-type terminals for 0.14 to 2.5 mm ² single-core/finely stranded	One screw-type terminal each for + and - for 0.5 to 10 mm ² single-core/finely stranded	Input, output and ground: one screw-type terminal each for 0.33 to 10 mm ² , single-core/finely stranded; relay contact: one screw-type terminal each for 0.5 to 2.5 mm ² , single-core/finely stranded
Dimensions (W x H x D) in mm	26 x 125 x 116	70 x 125 x 125	70 x 125 x 125
Weight approx.	0.15 kg	1.2 kg	1.0 kg
Mounting	Can be directly snapped onto the side of the basic unit	Snap-mounting on DIN rail EN 50022-35x15/7.5	Snap-mounting on DIN rail EN 50022-35x15/7.5

SITOP power · Standard 24 V

Additional components

Overview

SITOP select



Application

The diagnosis module is used together with 24 V power supply units to divide the load current between several branch circuits and to monitor the individual currents. Faults in the individual circuits resulting from an overload or short-circuit are detected and switched off selectively, and other load current paths therefore remain unaffected by the fault. This results in rapid fault diagnostics, and downtimes are minimized.

Technical specifications

Type	Module 4 x 10 A
Order No.	6EP1 961-2BA00
Input	DC voltage
Rated voltage $V_{in \text{ rated}}$	24 V DC
Voltage range	22 to 30 V
Overvoltage strength	35 V; 100 ms
Output	DC voltage
Rated voltage $V_{out \text{ rated}}$	$V_{out} - 0.5 \text{ V}$
Total tolerance/residual ripple	Corresponding to the input voltage
Number of output channels	4
Rated current	10 A per channel
$I_{out \text{ rated}}$ up to +60 °C	
Setting range	2 to 10 A per channel
Parallel connection of several channels	Not permissible
Efficiency	
Efficiency at $V_{out \text{ rated}}, I_{out \text{ rated}}$	Approx. 97 %
Power loss at $V_{out \text{ rated}}, I_{out \text{ rated}}$	Approx. 30 W
Switch-off characteristic per channel	
Overcurrent	$I_{out} = 1.0$ to $1.3 \times$ set value, switch-off after approx. 5 s
Current limitation	$I_{out} = 1.35 \times$ set value, switch-off after approx. 50 to 100 ms
Immediate switch-off	$I_{out} >$ set value and $V_{in} < 20 \text{ V}$
Reset	Using keys on module
Protection and monitoring	
Line protection	Electronic; additionally possible via accessible FK2 blade-type fuse (equipped when delivered with 15 A fuse) per channel
Status displays	Two-color LED per channel, green for output switched through, red for output switched off
Signaling contact	Common signal contact (NO contact)
Safety	
Protective class	Class III
Degree of protection (EN 60529)	IP20
TÜV test	Yes
CE marking	Yes
UL/cUL (CSA) approval	Yes, cULus listed (UL 508, CSA 22.2 No. 14-M91), File E197259; cURus recognized (UL 60950, CSA 22.2 No. 60950), File E151273
EMC	
Interference emission	EN 55022 Class B
Interference immunity	EN 61000-6-2
Operating specifications	
Ambient temperature range	0 to +60 °C with natural convection
Transportation and storage temperature range	-25 to +85 °C
Humidity rating	Climatic class 3K3 acc. to EN 60721, no condensation

Technical specifications (continued)

Type	Module 4 x 10 A
Order No.	6EP1 961-2BA00

Mechanical specifications

Connections

- Input +24 2 screw-type terminals for 0.33 to 10 mm²
- Input 0 V 2 screw-type terminals for 0.22 to 4 mm²
- Outputs 1 to 4 1 screw-type terminal per channel for 0.22 to 4 mm²
- Signalling contact 2 screw-type terminals for 0.22 to 4 mm²

Dimensions (W x H x D) in mm	72 x 90 x 90
Weight	0.4 kg
Mounting	Snap-mounting on DIN rail EN 50022-35x15/7.5

Characteristic curves

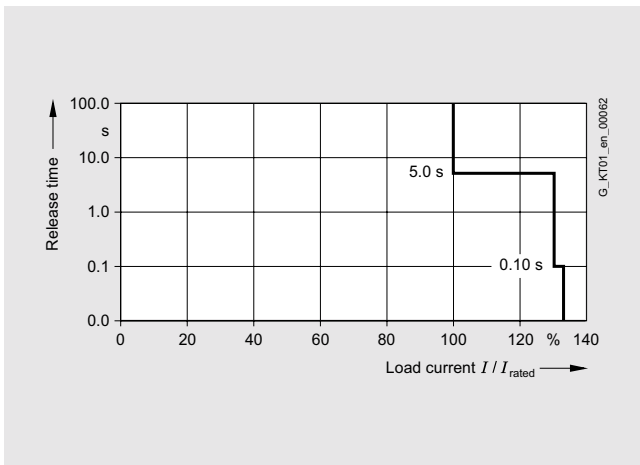

Switch-off characteristic

Schematics

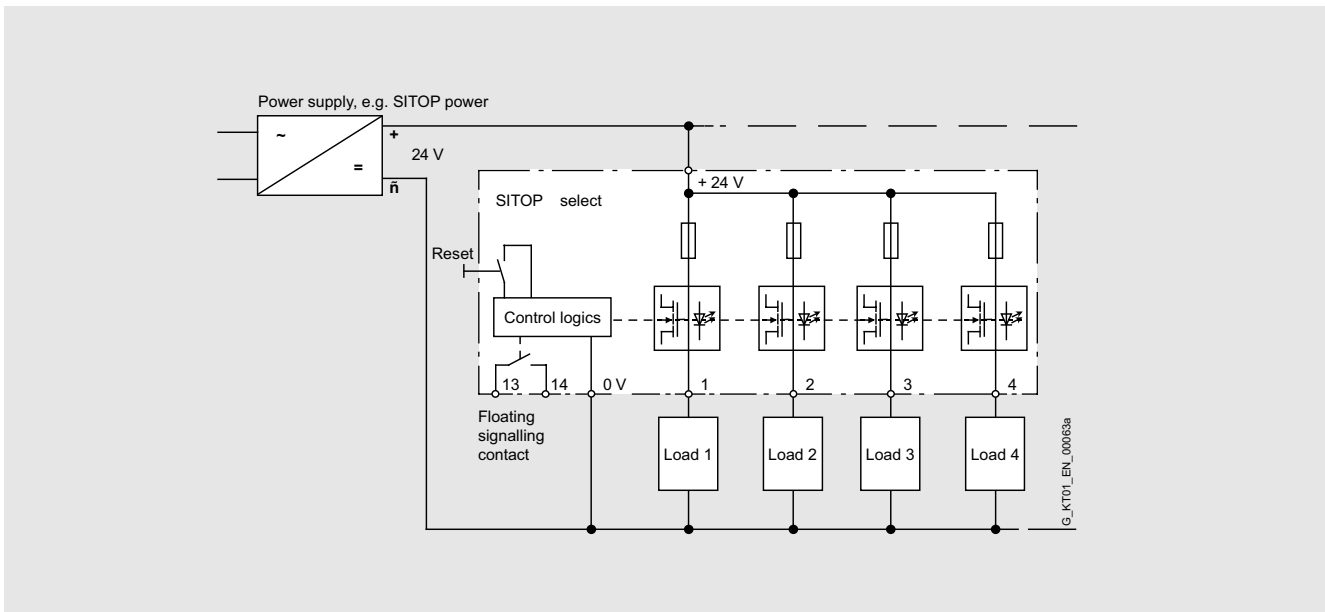

Basic circuit

SITOP power · Standard 24 V

Additional components

Overview

Mounting bracket

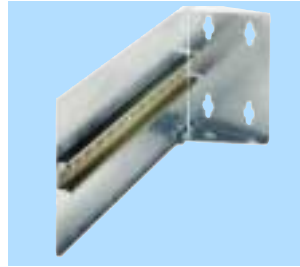

Application

Combination of a SITOP power supply unit with a 90° mounting bracket results in a minimum surface requirement on the rear panel of the switchgear cabinet (the width of the power supply unit becomes the depth, the depth becomes the width). The mounting bracket is suitable for switchgear cabinets with a depth of 240 mm or 320 mm or more.

Technical specifications

Mounting bracket	For depth 240 mm	For depth 320 mm
Order No.	6EP1 971-1AA01	6EP1 971-2BA00
Dimensions (W x H x D) in mm	50 x 159 x 236	100 x 150 x 320
Sheet plate thickness	2 mm	1.5 mm
Connected mounting rail	DIN rail EN 50022-35x7.5	DIN rail EN 50022-35x15
Weight approx.	0.9 kg	0.9 kg
Mounting	Can be screwed on level surface (keyhole mounting with M5 screws, drill hole distance 147.5 mm height)	Can be screwed on level surface (keyhole mounting with M6 screws, drill hole distance 90 mm height, 50 mm to the side)
Supplied accessories	Two M5 combi screws and two M5 self-tapping screws	Four M6 combi screws
Suitable for	SITOP 24 V/3.5 A (6EP1 332-1SH31) SITOP 24 V/5 A (6EP1 333-1AL12) SITOP 24 V/10 A (6EP1 334-1AL12) SITOP DC UPS module 40 A (6EP1 931-2FC01)	SITOP 24 V/10 A (6EP1 434-2BA00) SITOP 24 V/20 A (6EP1 336-2BA00, 6EP1 335-3BA00, 6EP1 436-2BA00, 6EP1 436-3BA00, 6EP1 457-3BA00, 6EP1 536-2AA00) SITOP 24 V/30 A (6EP1 437-2BA00) SITOP 24 V/40 A (6EP1 437-2BA10, 6EP1 337-3BA00, 6EP1 437-3BA00)

Mounting adapter for S7 rail and PS-CPU connecting comb

The single-phase SITOP power supply units 24 V/2 A (6ES7 307-1BA00-0AA0, 6ES7 305-1BA80-0AA0), 24 V/5 A (6ES7 307-1EA00-0AA0, 6ES7 307-1EA80-0AA0) and 24 V/10 A (6ES7 307-1KA01-0AA0) are special mechanical versions for SIMATIC S7-300.

They can be mounted on an S7 rail, and the connection to the new CPUs or the compact CPUs of the S7-300 can be established without problem using a supplied connecting comb.

Power supply units of same design without connecting comb, but with a supplied mounting adapter for DIN rail EN 50022-35x15, are available with the Order Nos. 6EP1 331-1SL11 (24 V/2 A), 6EP1 333-1SL11 (24 V/5 A) and 6EP1 334-1SL12 (24 V/10 A).

A connecting comb for older CPUs with product phase-out since 2003 as well as the mounting adapter are available as individual accessories.

Selection and Ordering Data

PS-CPU connecting comb (spare part for CPUs 313, 314, 315, 315/316/318-2 DP, IM153)	6ES7 390-7BA00-0AA0
Mounting adapter for DIN rail EN 50022-35x15	6ES7 390-6BA00-0AA0

IP65 connector seals

The single-phase SITOP power supply unit 24 V/10 A in IP65 degree of protection (6EP1 334-2CA00) has a design and functionality which are optimally adapted to the ET 200X distributed I/O system.

Thanks to integral plug-in connectors, it can be flush-mounted with the modules without any special wiring overhead.

If the power supply unit is operated outside the ET 200X system as a stand-alone power supply unit in IP65 degree of protection, connector seals are required to seal the integral plug-in connectors.

Selection and Ordering Data

IP65 connector seal for power supply unit 6EP1 334-2CA00	6EP1 971-2CA00
---	-----------------------

Circular input connectors and AS interface coupling module PG

A 6-pole circular connector with socket inset is required for the ASi power supply 30 V/2.4 A in IP65 degree of protection (6EP1 632-1AL01) for connection of the input side.

The connection of the ASi power supply to the ASi network is made using the coupling module PG.

Selection and Ordering Data

6-pole circular input connector with socket inset	6ES5 760-2CA11
AS interface coupling module PG	3RG9 220-0AA00

SITOP power · Standard 24 V

Additional components

Notes

8



SITOP power · Standard 24 V Uninterruptible power supplies

9



DC UPS	
9/2	Overview
9/2	DC UPS software
9/3	DC UPS module 6 A and 15 A
9/11	DC UPS module 40 A
9/14	Battery module 1.2 Ah
9/15	Battery module 2.5 Ah
9/16	Battery module 3.2 Ah
9/17	Battery module 7 Ah
9/18	Battery module 12 Ah



SITOP power · Standard 24 V Uninterruptible power supplies

DC UPS

Overview

By combining a DC UPS module with at least one 24 V battery module and a SITOP power supply unit, longer power failures can be bridged without any interruption.

This combination is used, for example, in machine tool manufacture, in the textile industry, with all types of production lines and filling systems, and in conjunction with 24 V industrial PCs. The negative effects which frequently result from power failures can thus be prevented.

For nonstop use in the event of power failures, Siemens offers the uninterruptible power supplies

- DC UPS 6 A
- DC UPS 15 A
- DC UPS 40 A

as well as the battery modules

- 1.2 Ah
- 3.2 Ah
- 7 Ah
- 12 Ah
- 2.5 Ah (high-temperature battery).

Selection table for battery modules with power failure buffer times

Load current	Battery module 1.2 Ah (6EP1935-6MC01)	Battery module 3.2 Ah (6EP1935-6MD11)	Battery module 7 Ah (6EP1935-6ME21)	Battery module 12 Ah (6EP1935-6MF01)	Battery module 2.5 Ah (6EP1935-6MD31)
1 A	30 min	2.5 h	6 h	10 h	2 h
2 A	11 min	45 min	2.5 h	4 h	45 min
4 A	2 min	20 min	45 min	2.5 h	20 min
6 A	1 min	10 min	30 min	1 h	13 min
8 A	-	4 min	20 min	40 min	9 min
10 A	-	1.5 min	15 min	30 min	7 min
12 A	-	1 min	10 min	25 min	5.5 min
14 A	-	50 s	8 min	20 min	4.5 min
16 A	-	40 s	6 min	15 min	4 min
20 A	-	-	2 min	11 min	-

Note:

- The power failure buffer times are based on the discharge period of the completely charged battery module down to a battery voltage of 21 V; ambient temperature 25 °C.
- With the DC UPS 40 A module, high electronically limited peak currents (120 A for approx. 12 ms, up to 40 A for several minutes depending on the battery capacity) are automatically delivered in the event of increased load current requirements (e.g. when switching on incandescent lamps, contactors with DC autotransformer winding, DC motors, DC/DC converters, electronic modules with high input capacitance). To achieve this, at least two battery modules of 7 Ah or more must be connected in parallel.
- Following a power failure, the battery module is automatically disconnected from the loads electronically and rapidly recharged at 0.2/0.4 A (DC UPS 6 A module), at 0.35/0.7 A (DC UPS 15 A module) or at 2 A (DC UPS 40 A module) (V/I characteristic with 27 V or 27.3 V end-of-charge voltage).

DC UPS software

The DC UPS 6 A and 15 A modules are optionally available with a serial interface or USB interface. All relevant messages concerning the status of the DC UPS can then be sent to a PC (e.g. SIMATIC PC). The SITOP DC UPS software, with which the signals sent from the DC UPS module can be processed further on the PC, is very easy to use. In monitoring mode, the statuses of the DC UPS module are visualized on the PC. The safe shutdown in the event of a power failure and the automatic restart of the PC are supported. It is also possible to freely define the responses to the various operating states of the DC UPS module, permitting extremely flexible incorporation into many different applications.

The software executes under the WinNT 4.0, Win2000 and WinXP operating systems. It is available as freeware on the SITOP Internet site for free downloading.

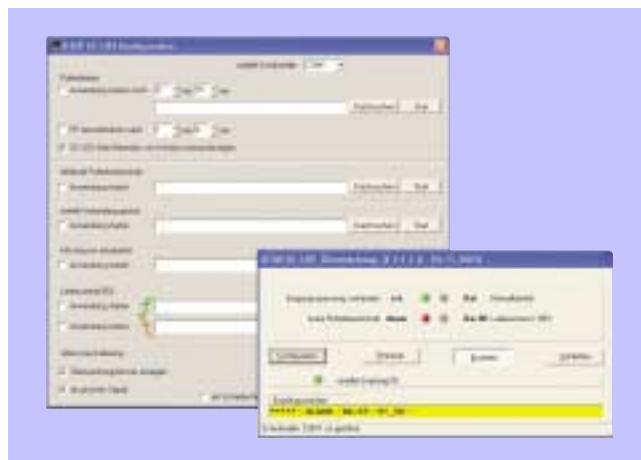

Monitoring and configuration windows of the SITOP UPS software

SITOP power · Standard 24 V Uninterruptible power supplies

DC UPS module 6 A and 15 A

Overview

- Compact design, only 50 mm wide
- Simple DIN rail mounting
- Absolutely interruption-free buffering of power failures through immediately electronic connection of the batteries as soon as the DC UPS input voltage drops below the value set using DIP switches
- High safety and availability through monitoring of operational readiness, battery supply line, battery aging (message "Battery replacement necessary") and battery charge (message "Battery charge >85%")
- Support of automatic restart of industrial PCs through selectable switch-off response
- Optionally with serial or USB interface.
SW tool as download at <http://www.siemens.de/sitop>
executes under WinNT4.0, Win2000 and WinXP.



Integration

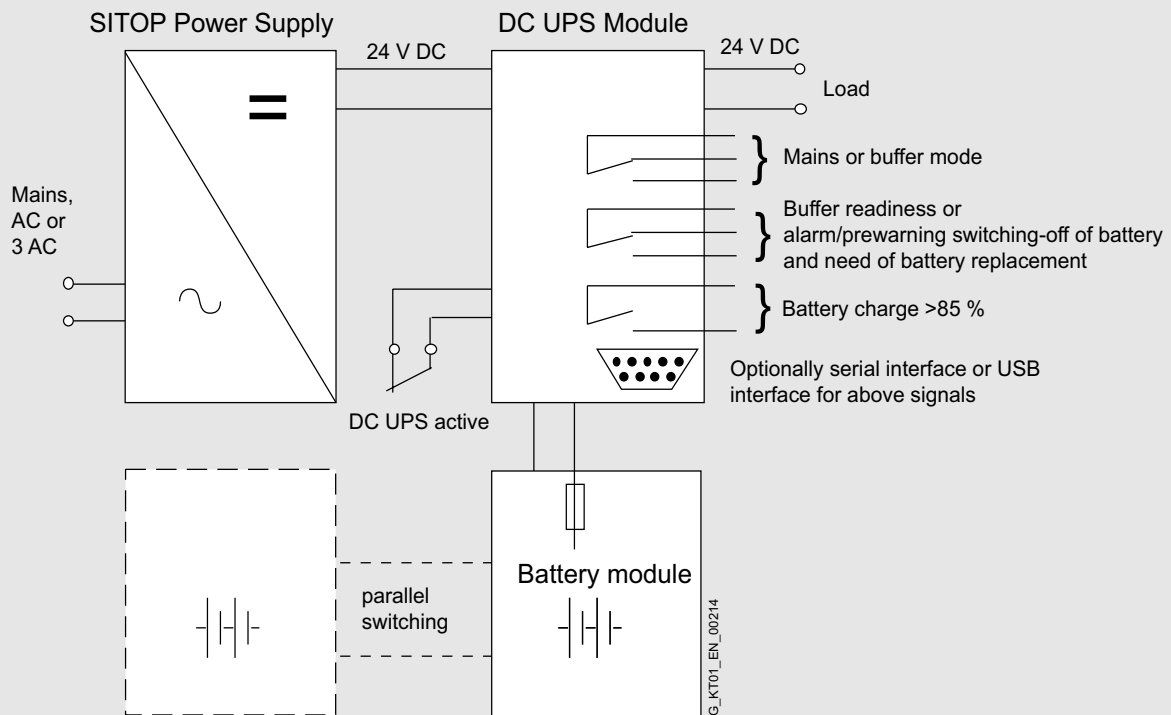

SITOP power · Standard 24 V Uninterruptible power supplies

DC UPS module 6 A and 15 A

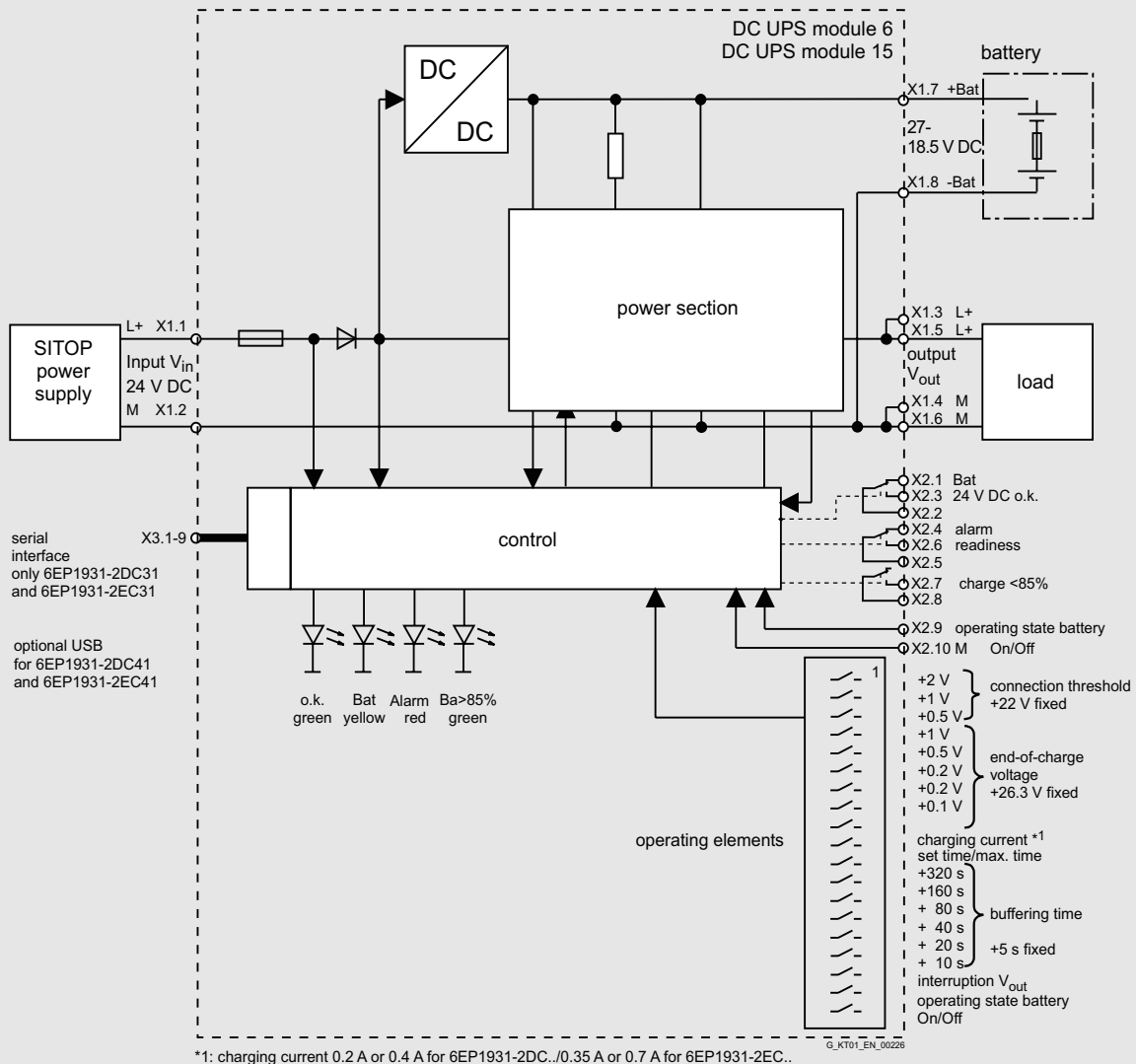

Function

The following timing diagrams show the characteristic of the input and output voltages at the terminals of the DC UPS module as well as the signal characteristic of the signals (relays) and the remote signal (interface) as examples.

"Long" power failure with DC UPS without serial or USB interface (Fig. 9/1)

Power recovery only following expiry of buffer time t_p (t_3 after t_4):

If the input voltage at the DC UPS module fails (time t_1), the battery "Bat" immediately takes over the DC supply, and the output voltage V_{out} is therefore retained completely without interruption.

The floating changeover contact "OK/Bat" switches to its deenergized position "Bat".

At the time t_1 , the buffer time t_p set on the DIP switches is started automatically.

The fact that the DIP switch is set to "Interruption output V_{out} " has no effect in this example because the input voltage returns at time t_3 only after the set buffer time (time t_4) has expired.

"Short" power failure with DC UPS without serial or USB interface (Fig. 9/2)

Power recovery prior to expiry of buffer time t_p (t_3 before t_4):

If the input voltage at the DC UPS module fails (time t_1), the battery "Bat" immediately takes over the DC supply, and the output voltage V_{out} is therefore retained completely without interruption.

The floating changeover contact "OK/Bat" switches to its deenergized position "Bat".

At the time t_1 , the buffer time t_p set on the DIP switches is started automatically.

With the selected DIP switch position "Interruption output V_{out} ", the output voltage V_{out} is automatically interrupted for 5 seconds following expiry of the set buffer time t_p (time t_4).

The battery has already been disconnected because the input voltage has returned at the time t_3 .

If the DIP switch is not set to "Interruption output V_{out} ", there is no interruption in this example because the input voltage has already returned at time t_3 prior to expiry of the set buffer time (time t_4).

Buffer time (time t_4) automatically interrupted for 5 s, and battery disconnected from the output at the same time which had not yet been disconnected because the input voltage was missing.

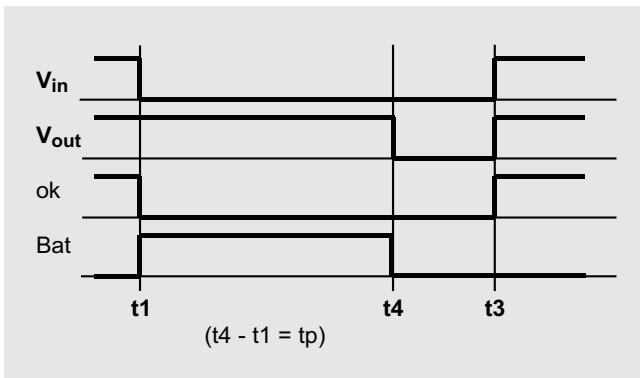

Fig. 9/1 "Long power failure"

DC UPS without serial or USB interface (6EP1931-2DC21/ -2EC21)

DIP switch settings on device: buffer time t_p (from 5 to 635 s with bottom row No. 2 to 7)/
/t = following setting (with bottom row No. 1 to left) / = with setting interruption V_{out}
(with bottom row No. 8 to left)

Legend:

V_{in} : input voltage at terminals X1.1 – X1.2
 V_{out} : output voltage at terminals X1.3 – X1.4 and X1.5 - X1.6
 ok: Signal for input voltage V_{in} OK or above the set battery connection threshold
 Bat: Signal for battery mode (batteries connected to the output, batteries supply the load)
 Remote: Signal for remote timer start with signal level = 0 at pin 7 of the 9-pin serial interface (pin 7 is normally the positive power supply of the interface)

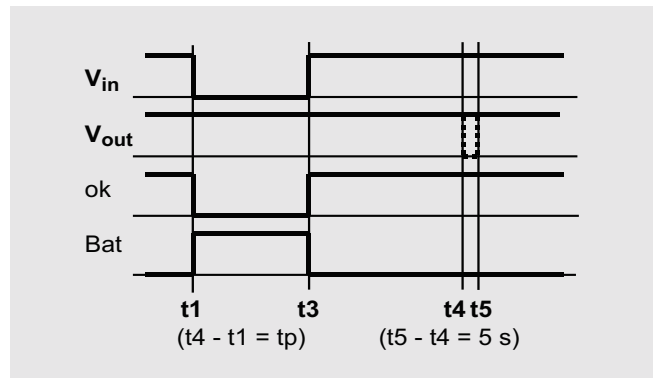

Fig. 9/2 "Short power failure"

t_1 : Input voltage V_{in} missing or falls below the set connection threshold
 t_2 : Buffer time set on the DIP switches is started by a remote timer start (signal level = 0)
 t_3 : Input voltage V_{in} is above the set connection threshold
 t_4 : End of set buffer time (output is switched off and/or battery disconnected)
 t_5 : Output is connected again 5 sec. after switch-off
 t_p : Buffer time set on the DIP switches (bottom row No. 2 to 7)

SITOP power · Standard 24 V Uninterruptible power supplies

DC UPS module 6 A and 15 A

Function (continued)

"Long" power failure with DC UPS with serial or USB interface (Fig. 9/3)

Power recovery only following expiry of buffer time t_p (t_3 after t_4):

If the input voltage at the DC UPS module fails (time t_1), the battery "Bat" immediately takes over the DC supply, and the output voltage V_{out} is therefore retained completely without interruption.

The floating changeover contact "OK/Bat" switches to its deenergized position "Bat".

At the user-selectable time t_2 , the buffer time t_p set on the DIP switches is started by means of the signal "Remote timer start" (signal level = 0 at pin 7 of the 9-pin serial interface).

The fact that the DIP switch is set to "Interruption output V_{out} " has no effect in this example because the input voltage returns at time t_3 after the set buffer time (time t_4) has expired.

Note: Without a remote signal level = 0 with the set duration $t = \text{max.}$, there is no interruption in the output voltage here because the set buffer time is not started (or only interrupted if the exhaustive discharge protection disconnects the battery and the input voltage has not returned by then).

"Short" power failure with DC UPS with serial or USB interface (Fig. 9/4)

Power recovery prior to expiry of buffer time t_p (t_3 before t_4):

If the input voltage at the DC UPS module fails (time t_1), the battery "Bat" immediately takes over the DC supply, and the output voltage V_{out} is therefore retained completely without interruption.

The floating changeover contact "OK/Bat" switches to its deenergized position "Bat".

At the user-selectable time t_2 , the buffer time t_p set on the DIP switches is started by means of the signal "Remote timer start" (signal level = 0 at pin 7 of the 9-pin serial interface following previous signal timing according to Instruction Manual).

With the selected DIP switch position "Interruption output V_{out} ", the output voltage V_{out} is automatically interrupted for 5 seconds following expiry of the set buffer time t_p (time t_4).

The battery has already been disconnected because the input voltage has returned at the time t_3 .

The output voltage interruption of V_{out} for 5 s permits an automatic restart for many industrial PCs, even if the mains voltage (or the input voltage V_{in} on the DC UPS module) returns during shutting-down of the PC, as in this example.

Note: Without a remote signal level = 0 with setting $t = \text{max.}$ duration, there is no interruption in the output voltage here because the set buffer time is not started.

9

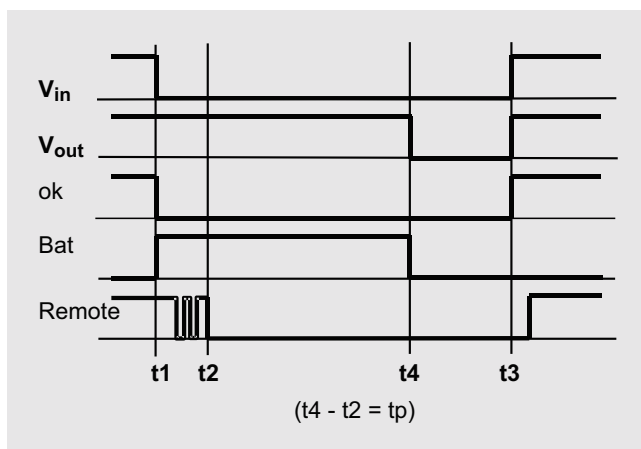

Fig. 9/3 "Long power failure"

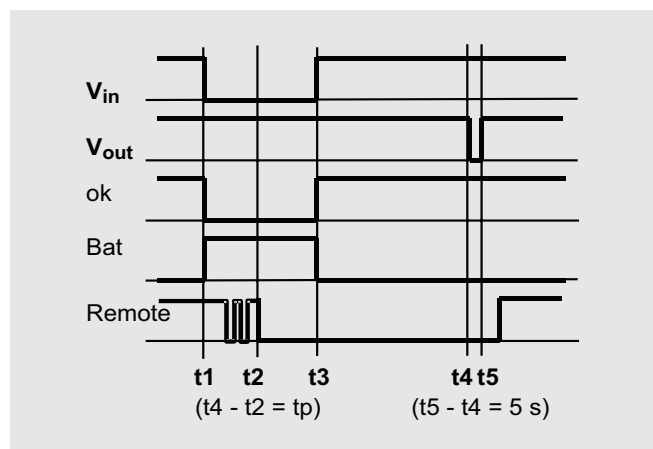

Fig. 9/4 "Short power failure"

DC UPS with serial or USB interface (6EP1931-2DC31/-2DC41/-2EC31/-2EC41)

DIP switch settings on device: buffer time t_p (from 5 to 635 s with bottom row No. 2 to 7)/
 $t = \text{max.}$ time (with bottom row No. 1 to right)/interruption V_{out} (with bottom row No. 8 to left)

Legend:

V_{in} : input voltage at terminals X1.1 – X1.2
 V_{out} : output voltage at terminals X1.3 – X1.4 and X1.5 - X1.6
 ok: Signal for input voltage V_{in} OK or above the set battery connection threshold
 Bat: Signal for battery mode (batteries connected to the output, batteries supply the load)
 Remote: Signal for remote timer start with signal level = 0 at pin 7 of the 9-pin serial interface (pin 7 is normally the positive power supply of the interface)

t_1 : Input voltage V_{in} missing or falls below the set connection threshold
 t_2 : Buffer time set on the DIP switches is started by a remote timer start (signal level = 0)
 t_3 : Input voltage V_{in} is above the set connection threshold
 t_4 : End of set buffer time (output is switched off and/or battery disconnected)
 t_5 : Output is connected again 5 sec. after switch-off
 t_p : Buffer time set on the DIP switches (bottom row No. 2 to 7)

Technical specifications

DC UPS module 6	
Order No.	6EP1 931-2DC21 6EP1 931-2DC31 (with serial interface) 6EP1 931-2DC41 (with USB interface)
Input L+/ M with normal mode	Stabilized direct voltage 24 V DC 22 to 29 V DC 22.5 V DC ± 0.1 V (default setting), adjustable in range from 22 to 25.5 V DC (in intervals of 0.5 V)
Rated voltage $V_{in\ rated}$ ¹⁾ Voltage range Connection threshold for battery	6 A + approx. 0.6 A with empty battery
Mains buffering	Mains buffering or buffer time dependent on connected battery and load current: • With 3.2 Ah battery module (6EP1935-6MD11) at +25 °C: approx. 10 min at 6 A; 20 min at 4 A; 45 min at 2 A • With 7 Ah battery module (6EP1935-6ME21) at +25 °C: approx. 30 min at 6 A; 45 min at 4 A; 150 min at 2 A
On/off control circuit	External floating NO contact required (load max. 15 V DC/max. 10 mA). With the control circuit open, the battery is disconnected from the output L+, and the mains buffering is therefore canceled.
Buffer time	Adjustable using DIP switches to maximum buffer time until forced switch-off by exhaustive discharge protection (at approx. 19 V) or to timed buffering from 5 to 635 seconds (in intervals of 10 s)
Output L+/ M with normal mode	24 V DC (output voltage of SITOP power supply unit) Input voltage V_{in} less approx. 0.5 V DC 0 to 6 A Electronic current limitation to 1.05 to 1.4 × $I_{out\ rated}$ for approx. 80 ms, then electronic switching-off of output with automatic attempts at restarting (approx. 20 s interval between the restart attempts)
Rated voltage $V_{out\ rated}$ Voltage range Output current I_{out} Dynamic current with overload	Electronic current limitation to 1.5 to 3 × $I_{out\ rated}$ for approx. 20 ms, then electronic switching-off of output with automatic attempts at restarting (approx. 20 s interval between the restart attempts)
Dynamic current with short-circuit	Electronic current limitation to 1.5 to 3 × $I_{out\ rated}$ for approx. 20 ms, then electronic switching-off of output with automatic attempts at restarting (approx. 20 s interval between the restart attempts)
Output L+/ M with battery mode	24 V DC (from battery module) 27 to 19 V DC; 27 V at no load, 25 V at $I_{out} = 0.05 \times C \times 1/h$ or 24 V at $I_{out} = 1 \times C \times 1/h$ or 23 V at $I_{out} = 2 \times C \times 1/h$ (C = total connected battery capacity in Ah), 19 V switch-off threshold for exhaustive discharge protection
Rated voltage $V_{out\ rated}$ Voltage range, approx.	0 to 6 A (permanently reliable) Electronic current limitation to 1.05 to 1.4 × $I_{out\ rated}$ for approx. 80 ms, then electronic switching-off of output with automatic attempts at restarting (approx. 20 s interval between the restart attempts)
Output current I_{out} Dynamic current with overload	Electronic current limitation to 1.5 to 3 × $I_{out\ rated}$ for approx. 20 ms, then electronic switching-off of output with automatic attempts at restarting (approx. 20 s interval between the restart attempts)
Dynamic current with short-circuit	Electronic current limitation to 1.5 to 3 × $I_{out\ rated}$ for approx. 20 ms, then electronic switching-off of output with automatic attempts at restarting (approx. 20 s interval between the restart attempts)
Output +Bat / -Bat with normal mode	I-V charging characteristic (first constant current I, then constant voltage V) 27.0 V DC ± 0.1 V (default setting), adjustable in range from 26.3 to 29.3 V (in intervals of 0.1 V) Approx. 0.4 A (default setting), adjustable to 0.2 A or 0.4 A (charging is carried out with the on/off circuit closed or open)
End-of-charge voltage V	Approx. 0.4 A (default setting), adjustable to 0.2 A or 0.4 A (charging is carried out with the on/off circuit closed or open)
Charging current I	Approx. 0.4 A (default setting), adjustable to 0.2 A or 0.4 A (charging is carried out with the on/off circuit closed or open)
Efficiency / power loss	At $V_{out\ rated}$, $I_{out\ rated}$ approx. 95 %/7 W With battery operation, approx. 94.5 %/8 W
Protection and monitoring	Against input voltage and batteries with reversed polarity Electronic current limitation to 1.05 to 1.4 × $I_{out\ rated}$ for approx. 80 ms, then electronic switching-off of output with automatic attempts at restarting (approx. 20 s interval between the restart attempts)
Polarity reversal protection	Electronic current limitation to 1.5 to 3 × $I_{out\ rated}$ for approx. 20 ms, then electronic switching-off of output with automatic attempts at restarting (approx. 20 s interval between the restart attempts).
Overload protection	Internal, non-accessible 16 A fuse
Short-circuit protection	Automatic switch-off at battery voltage below approx. 19 V
Exhaustive discharge protection	Alarm signal if battery circuit is not closed or if it opens during operation (cyclic test approx. every 20 s)
Monitoring "Wire breakage, battery circuit"	Alarm signal flashing at approx. 0.25 Hz (approx. 2 s alarm, approx. 2 s no alarm, approx. 2 s alarm etc.)
Monitoring "Battery replacement necessary"	Check every 4 hours if no buffer mode or switch-off has taken place within 4 hours
Monitoring "Battery charge > 85 %"	Indication whether batteries are charged to at least 85 % of the rated capacity

1) All SITOP 24 V DC power supply units are permissible without limitation.

SITOP power · Standard 24 V

Uninterruptible power supplies

DC UPS module 6 A

Technical specifications (continued)

DC UPS module 6	
Order No.	6EP1 931-2DC21 6EP1 931-2DC31 (with serial interface) 6EP1 931-2DC41 (with USB interface)
Signalling ¹⁾	
Normal mode	Green LED (OK) and floating changeover contact "24 V DC OK/Bat" to position "24 V DC OK" ²⁾
Buffer or battery mode (battery supplies load on its own, or in addition to PS in event of overload)	Yellow LED (Bat) and floating changeover contact "24 V DC OK/Bat" to position "Bat" (= de-energized position)
Alarm (buffer readiness missing or pre-warning at < 20.4 V battery voltage)	Red LED (Alarm) and floating changeover contact to position "Alarm" (= de-energized position). Causes for absence of buffer readiness during normal mode could be: Operating status Off or open on/off control circuit, battery module not connected, battery faulty or with reversed polarity (battery voltage < 18.5 V) or wire breakage between battery and UPS module. Scanning and thus updating of the signal every 20 s. Causes for absence of buffer readiness during buffer mode could be: Battery voltage has fallen below 20.4 V DC (= prewarning prior to switching-off by exhaustive discharge protection) as well as switching-off of battery because of overload, short-circuit, exhaustive discharge protection or expired buffer time. The Red LED then goes off.
"Battery replacement necessary"	Red LED (Alarm) flashes at 0.25 Hz and floating changeover contact (Alarm) switches at approx. 0.25 Hz
"Battery charge > 85 %"	Green LED (Bat > 85 %) and floating NO contact closed (de-energized position = open)
Optional interface and software	
Serial interface	Only with 6EP1 931-2DC31 Output of all signals, and receipt of signal "Remote timer start". Techn. design: PC-compatible. 8N1 send and receive, 9600 baud, 8 data bits, 1 stop bit, no parity bit. Required connection to PC: 1 : 1 continuous 9-pole SUB D extension cable (male/female), only pin 2 (RXD), pin 3 (TDX) and pin 7 (RTS) are required.
USB interface	Only with 6EP1 931-2DC41 Output of all signals, and receipt of signal "Remote timer start". Techn. design: Specification 2.0 with full speed, i.e. 2 Mbit/s. Powered by DC UPS with +5 V ("self powered"). Required connection to PC: Commercially available 4-core shielded cable, 90 Ohm, max. 5 m, USB series "A" connector to PC and USB series "B" connector to DC UPS
Software	A software tool (executes under WinNT4.0, Win 2000 and WinXP) for reading and processing the signals is available on the Internet at http://www.siemens.de/sitop as a download. Further information on the interface can also be found there.
Control signals	
On/off control signal	By opening the control circuit (or using DIP switch on device), the buffer mode is terminated, or the battery is disconnected from the output. All other functions are retained.
"Remote timer start" via serial interface or USB	Starts the mains buffering for the set buffer time
Safety	
Galvanic isolation primary/secondary	No
Protective class	Class III (ext. circuit and power supply unit: SELV voltage acc. to EN 60950 is required)
EMC	
Interference emission	RI suppression acc. to EN 55022, limit characteristic B
Interference immunity	Interference immunity acc. to EN 61000-6-2
Ambient conditions	
Ambient temperature during operation	0 to +60 °C with natural convection
Transportation and storage temperature	-40 to +70 °C
Degree of protection (EN 60529)	IP20
Humidity rating	Conditions of use acc. to EN 60721, climatic class 3K3 (relative humidity 5 % to 85 % and absolute humidity 1 g/m ³ to 25 g/m ³ ; no condensation)
Approvals	
CE	CE conformity acc. to 98/336 EEC and 73/23 EEC
UL / cUL	UL 508 / CSA C22.2, File E197259
Mechanical specifications	
Connections for 24 V DC input	2 screw-type terminals for 1 to 4 mm ² /17 to 11 AWG
Connections for 24 V DC output	4 screw-type terminals for 1 to 4 mm ² /17 to 11 AWG
Connections for 24 V DC battery module	2 screw-type terminals for 1 to 4 mm ² /17 to 11 AWG
Connections for control circuit and signals	10 screw-type terminals for 0.5 to 2.5 mm ² /20 to 13 AWG
Dimensions (W x H x D) in mm	50 x 125 x approx. 125
Required clearance	50 mm above and 50 mm below the device
Weight	Approx. 0.4 kg (with serial or USB interface: approx. 0.45 kg)
Mounting	Snap-mounting on DIN rail EN 50022-35x15/7.5

1) Permissible contact rating: 60 V DC/1 A or 30 V AC/1 A.

2) "24 V DC OK" means: Voltage of power supply unit is greater than the battery connection threshold set on the DC UPS module 6.

Technical specifications

DC UPS module 15	
Order No.	6EP1 931-2EC21 6EP1 931-2EC31 (with serial interface) 6EP1 931-2EC41 (with USB interface)
Input L+/ M with normal mode	Stabilized direct voltage
Rated voltage $V_{in\ rated}^{1)}$	24 V DC
Voltage range	22 to 29 V DC
Connection threshold for battery	22.5 V DC \pm 0.1 V (default setting), adjustable in range from 22 to 25.5 V DC (in intervals of 0.5 V)
Rated current $I_{in\ rated}$	15 A + approx. 1 A with empty battery
Mains buffering	
Mains buffering or buffer time	Dependent on connected battery and load current: <ul style="list-style-type: none"> • With 3.2 Ah battery module (6EP1935-6MD11) at +25 °C: approx. 45 s at 15 A; 1.5 min at 10 A; 13 min at 5 A • With 7 Ah battery module (6EP1935-6ME21) at +25 °C: approx. 7 min at 15 A; 15 min at 10 A; 38 min at 5 A
On/off control circuit	External floating NO contact required (load max. 15 V DC/max. 10 mA). With the control circuit open, the battery is disconnected from the output L+, and the mains buffering is therefore canceled.
Buffer time	Adjustable using DIP switches to maximum buffer time until forced switch-off by exhaustive discharge protection (at approx. 19 V) or to timed buffering from 5 to 635 seconds (in intervals of 10 s)
Output L+/ M with normal mode	
Rated voltage $V_{out\ rated}$	24 V DC (output voltage of SITOP power supply unit)
Voltage range	Input voltage V_{in} less approx. 0.5 V DC
Output current I_{out}	0 to 15 A
Dynamic current with overload	Electronic current limitation to 1.05 to 1.4 x $I_{out\ rated}$ for approx. 80 ms, then electronic switching-off of output with automatic attempts at restarting (approx. 20 s interval between the restart attempts)
Dynamic current with short-circuit	Electronic current limitation to 1.5 to 3 x $I_{out\ rated}$ for approx. 20 ms, then electronic switching-off of output with automatic attempts at restarting (approx. 20 s interval between the restart attempts)
Output L+/ M with battery mode	
Rated voltage $V_{out\ rated}$	24 V DC (from battery module)
Voltage range, approx.	27 to 19 V DC; 27 V at no load, 25 V at $I_{out} = 0.05 \times C \times 1/h$ or 24 V at $I_{out} = 1 \times C \times 1/h$ or 23 V at $I_{out} = 2 \times C \times 1/h$ (C = total connected battery capacity in Ah), 19 V switch-off threshold for exhaustive discharge protection
Output current I_{out}	0 to 15 A (permanently reliable)
Dynamic current with overload	Electronic current limitation to 1.05 to 1.4 x $I_{out\ rated}$ for approx. 80 ms, then electronic switching-off of output with automatic attempt at restarting (approx. 20 s interval between the restart attempts)
Dynamic current with short-circuit	Electronic current limitation to 1.5 to 3 x $I_{out\ rated}$ for approx. 20 ms, then electronic switching-off of output with automatic attempt at restarting (approx. 20 s interval between the restart attempts)
Output +Bat / -Bat with normal mode	
I-V charging characteristic (first constant current I, then constant voltage V)	
End-of-charge voltage V	27.0 V DC \pm 0.1 V (default setting), adjustable in range from 26.3 to 29.3 V (in intervals of 0.1 V)
Charging current I	Approx. 0.7 A (default setting), adjustable to 0.35 A or 0.7 A (charging is carried out with the on/off circuit closed or open)
Efficiency / power loss	
At $V_{out\ rated} \cdot I_{out\ rated}$ approx.	96.2 %/14 W
With battery operation, approx.	96 %/15 W
Protection and monitoring	
Polarity reversal protection	Against input voltage and batteries with reversed polarity
Overload protection	Electronic current limitation to 1.05 to 1.4 x $I_{out\ rated}$ for approx. 80 ms, then electronic switching-off of output with automatic attempts at restarting (approx. 20 s interval between the restart attempts)
Short-circuit protection	Electronic current limitation to 1.5 to 3 x $I_{out\ rated}$ for approx. 20 ms, then electronic switching-off of output with automatic attempts at restarting (approx. 20 s interval between the restart attempts). Internal, non-accessible 16 A fuse
Exhaustive discharge protection	Automatic switch-off at battery voltage below approx. 19 V
Monitoring "Wire breakage, battery circuit"	Alarm signal if battery circuit is not closed or if it opens during operation (cyclic test approx. every 20 s)
Monitoring "Battery replacement necessary"	Alarm signal flashing at approx. 0.25 Hz (approx. 2 s alarm, approx. 2 s no alarm, approx. 2 s alarm etc.). Check every 4 hours if no buffer mode or switch-off has taken place within 4 hours
Monitoring "Battery charge > 85 %"	Signal whether batteries are charged to at least 85 % of the rated capacity

1) All SITOP 24 V DC power supply units are permissible without limitation.

SITOP power · Standard 24 V

Uninterruptible power supplies

DC UPS module 15 A

Technical specifications (continued)

DC UPS module 15	
Order No.	6EP1 931-2EC21 6EP1 931-2EC31 (with serial interface) 6EP1 931-2EC41 (with USB interface)
Signalling ¹⁾	<p>Normal mode</p> <p>Buffer or battery mode (battery supplies load on its own, or in addition to PS in event of overload)</p> <p>Alarm (buffer readiness missing or pre-warning at < 20.4 V battery voltage)</p> <p>Green LED (OK) and floating changeover contact "24 V DC OK/Bat" to position "24 V DC OK" ²⁾</p> <p>Yellow LED (Bat) and floating changeover contact "24 V DC OK/Bat" to position "Bat" (= de-energized position)</p> <p>Red LED (Alarm) and floating changeover contact to position "Alarm" (= de-energized position). Causes for absence of buffer readiness during normal mode could be: Operating status Off or open on/off control circuit, battery module not connected, battery faulty or with reversed polarity (battery voltage < 18.5 V) or wire breakage between battery and UPS module. Scanning and thus updating of the signal every 20 s.</p> <p>Causes for absence of buffer readiness during buffer mode could be: Battery voltage fallen below 20.4 V DC (= prewarning prior to switching-off by exhaustive discharge protection) as well as switching-off of battery because of overload, short-circuit, exhaustive discharge protection or expired buffer time. The Red LED then goes off.</p> <p>Red LED (Alarm) flashes at 0.25 Hz and floating changeover contact (Alarm) switches at approx. 0.25 Hz</p> <p>Green LED (Bat > 85 %) and floating NO contact closed (de-energized position = open)</p>
"Battery replacement necessary"	Red LED (Alarm) flashes at 0.25 Hz and floating changeover contact (Alarm) switches at approx. 0.25 Hz
"Battery charge > 85 %"	Green LED (Bat > 85 %) and floating NO contact closed (de-energized position = open)
Optional interface and software	
Serial interface	Only with 6EP1 931-2EC31 Output of all signals, and receipt of signal "Remote timer start". Techn. design: PC-compatible. 8N1 send and receive, 9600 baud, 8 data bits, 1 stop bit, no parity bit. Required connection to PC: 1 : 1 continuous 9-pole SUB D extension cable (male/female), only pin 2 (RXD), pin 3 (TDX) and pin 7 (RTS) are required.
USB interface	Only with 6EP1 931-2EC41 Output of all signals, and receipt of signal "Remote timer start". Techn. design: Specification 2.0 with full speed, i.e. 2 Mbit/s. Powered by DC UPS with +5 V ("self powered"). Required connection to PC: Commercially available 4-core shielded cable, 90 Ohm, max. 5 m, USB series "A" connector to PC and USB series "B" connector to DC UPS
Software	A software tool (executes under WinNT4.0, Win 2000 and WinXP) for reading and processing the signals is available on the Internet at http://www.siemens.de/sitop as a download. Further information on the interface can also be found there.
Control signals	
On/off control signal	By opening the control circuit (or using DIP switch on the device), buffer mode is terminated, or the battery is disconnected from the output. All other functions are retained.
"Remote timer start" via serial interface or USB	Starts the mains buffering for the set buffer time
Safety	
Galvanic isolation primary/secondary	No
Protective class	Class III (ext. circuit and power supply unit: SELV voltage acc. to EN 60950 is required)
EMC	
Interference emission	RI suppression acc. to EN 55022, limit characteristic B
Interference immunity	Interference immunity acc. to EN 61000-6-2
Ambient conditions	
Ambient temperature during operation	0 to +60 °C with natural convection
Transportation and storage temperature	-40 to +70 °C
Degree of protection (EN 60529)	IP20
Humidity rating	Conditions of use acc. to EN 60721, climatic class 3K3 (relative humidity 5 % to 85 % and absolute humidity 1 g/m ³ to 25 g/m ³ ; no condensation)
Approvals	
CE	CE conformity acc. to 98/336 EEC and 73/23 EEC
UL / cUL	UL 508 / CSA C22.2, File E197259
Mechanical specifications	
Connections for 24 V DC input	2 screw-type terminals for 1 to 4 mm ² /17 to 11 AWG
Connections for 24 V DC output	4 screw-type terminals for 1 to 4 mm ² /17 to 11 AWG
Connections for 24 V DC battery module	2 screw-type terminals for 1 to 4 mm ² /17 to 11 AWG
Connections for control circuit and signals	10 screw-type terminals for 0.5 to 2.5 mm ² /20 to 13 AWG
Dimensions (W x H x D) in mm	50 x 125 x approx. 125
Required clearance	50 mm above and 50 mm below the device
Weight	Approx. 0.4 kg (with serial or USB interface: approx. 0.45 kg)
Mounting	Snap-mounting on DIN rail EN 50022-35x15/7.5

1) Permissible contact rating: 60 V DC/1 A or 30 V AC/1 A.

2) "24 V DC OK" means: Voltage of power supply unit is greater than the battery connection threshold set on the DC UPS module 15.

SITOP power · Standard 24 V Uninterruptible power supplies

DC UPS module 40 A

Overview

- Mounting depth only approx. 65 mm
- Rated output power 480 W with one battery module, 960 W with two battery modules
- Extremely high efficiency of approx. 99% as result of patented circuit concept
- Immediate electronic connection of battery as soon as the consumer voltage or the voltage present between the L+/M terminals of the DC UPS module falls below a value of 22.5 V DC. The consumer voltage only drops to 22 V DC for a maximum of 1 ms.
- High electronically limited peak currents (120 A for approx. 12 ms, up to 40 A for several minutes depending on the battery capacity) are automatically delivered in the event of increased load current requirements (e.g. when switching on incandescent lamps, contactors with DC autotransformer winding, DC motors, DC/DC converters, electronic modules with high input capacitance). To achieve this, at least two battery modules of 7 Ah or more must be connected in parallel.
- Following a power failure, the battery module is automatically disconnected from the consumers electronically and rapidly recharged with a constant current of 2 A (V/I characteristic with 27.3 V end-of-charge voltage).



- Signalling
 - Green LED/yellow LED and floating changeover contact for mains/battery mode
 - Red LED and floating changeover contact for buffer readiness (LED off)/ alarm (LED on)

Integration

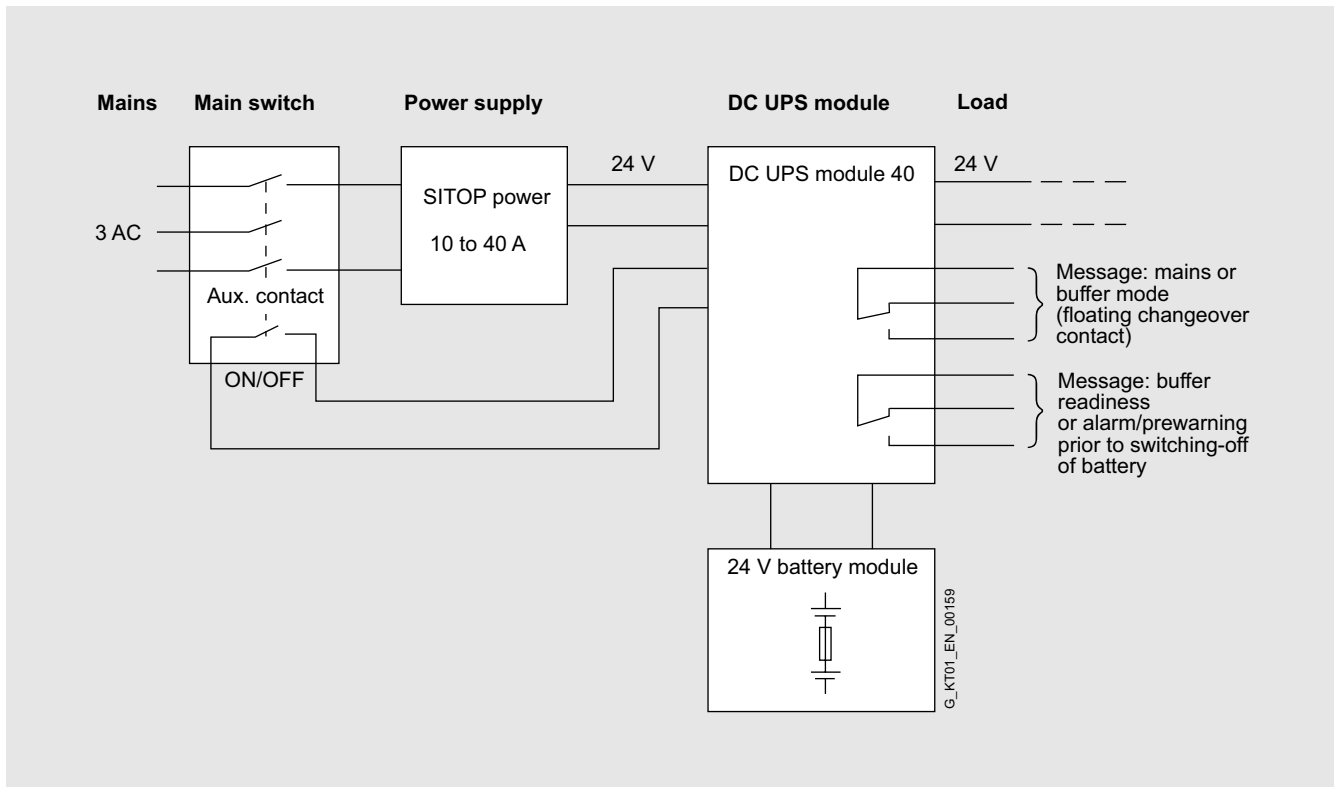

Block diagram: Configuration of uninterruptible SITOP power supply 40 A

SITOP power · Standard 24 V Uninterruptible power supplies

DC UPS module 40 A

Integration (continued)

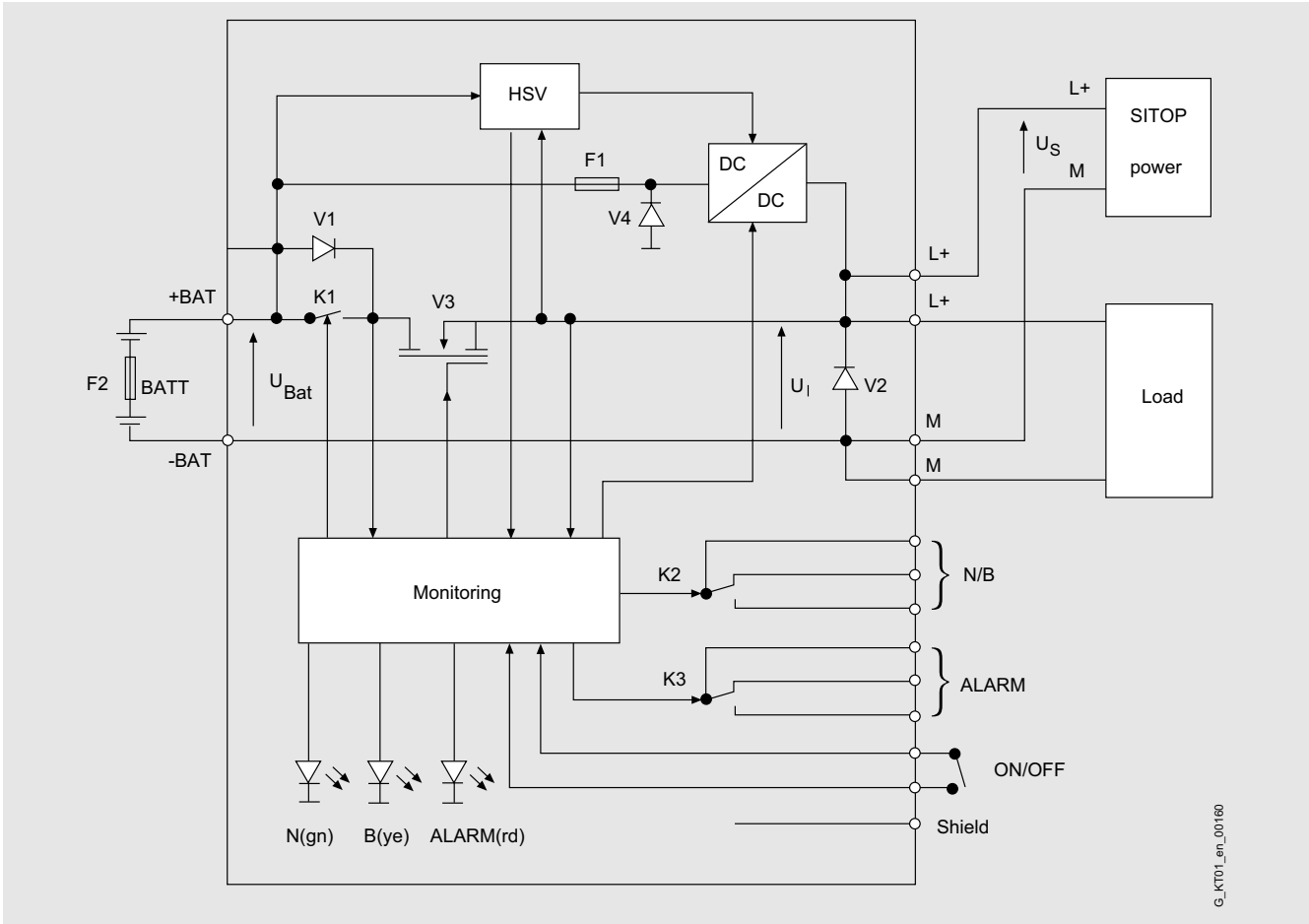

Block diagram

Characteristic curves

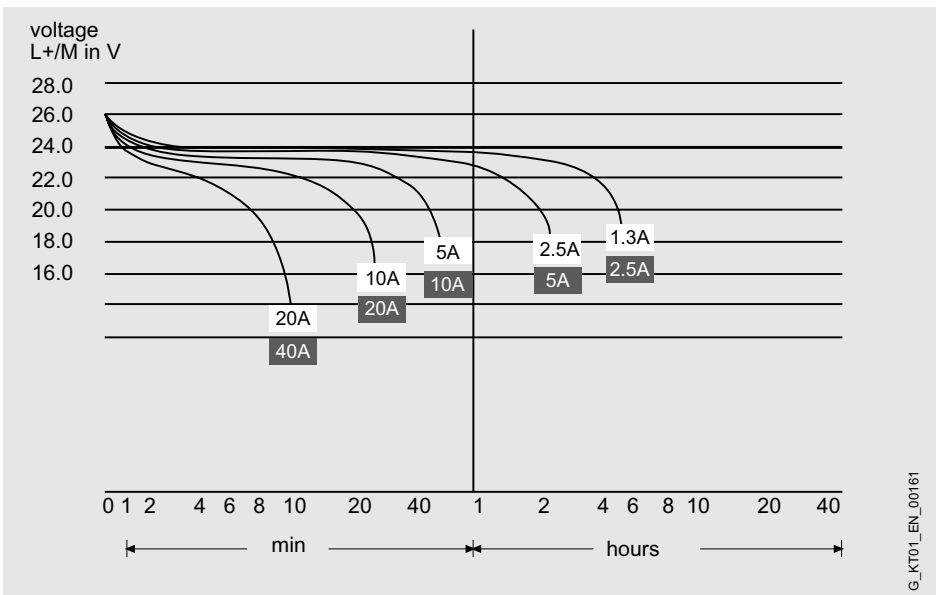

Voltage characteristic between the terminals L+/M of the DC UPS module with connection of 1 battery module 24 V/7 Ah depending on duration and load current.

Parameters: Load current 20 A/ 10 A/5 A/2.5 A/1.3 A;

2 battery modules 24 V/7 Ah

Parameters: Load current 40 A/ 20 A/10 A/5 A/2.5 A

Technical specifications

	DC UPS module 40 6EP1 931-2FC01
Order No.	6EP1 931-2FC01
Input L+/ M with normal mode	Stabilized direct voltage
Rated voltage $V_{in\ rated}$ ¹⁾	24 V DC
Voltage range	23.5 to 26 V DC
Overvoltage strength	VDE 0160 A1 (April 1989), limit curve B2 ($2 \times V_{rated}$, 0.4 ms)
Connection threshold for battery	Approx. 22.5 V
Mains buffering at $I_{out\ rated}$	Dependent on connected battery, see discharge characteristic of battery module
Rated current $I_{in\ rated}$	40 A
On/off control circuit	External floating NO contact required (load max. 12 V DC/max. 5 mA). With the control circuit open, the battery is disconnected from the output L+, and the mains buffering is therefore canceled.
Output L+/ M with normal mode	24 V DC (output voltage of SITOP power supply unit)
Rated voltage $V_{out\ rated}$	Input voltage less approx. 0.1 V
Voltage range	0 to 37 A (max. 3 A required for battery charging)/ 0 to 40 A
Output current I_{out} with discharged/charged battery	
Output L+/ M with battery mode	24 V DC (from battery module)
Rated voltage $V_{out\ rated}$	27 to 18.5 V DC; 27 V at no load, 25 V at $I_{out} = 0.05 \times C \times 1/h$ or 24 V at $I_{out} = 1 \times C \times 1/h$ or 23 V at $I_{out} = 2 \times C \times 1/h$ (C = total connected battery capacity in Ah), 18.5 V switch-off threshold for exhaustive discharge protection
Voltage range, approx.	0 to 25 A
Output current I_{out} with a battery module of 7 Ah or more	0 to 40 A
Output current I_{out} with two battery modules of 7 Ah or more	0 to 40 A
Dyn. V/I with short-circuit	Typ. 120 A for approx. 12 ms (with two battery modules of 7 Ah or more)
Output +Bat/-Bat with normal mode	I-V charging characteristic (first constant current I, then constant voltage V)
End-of-charge voltage	27.3 V \pm 0.3 V
Charging current	0 to 2.5 A (typ. 2 A); charging is carried out with the on/off circuit closed or open
Efficiency/power loss	
at $V_{out\ rated}$, $I_{out\ rated}$ and fully charged battery	Approx. 99 %/approx. 7 W
With battery operation	Approx. 97 %/approx. 30 W
Protection and monitoring	
Exhaustive discharge protection	Automatic switch-off at battery voltage < 18.5 V
Short-circuit protection	Temperature monitoring of circuit-breaker, electronic switch-off with automatic restart
Monitoring "Wire breakage, battery circuit"	Alarm signal flashing at approx. 1/3 Hz if battery circuit is not closed or if it opens during operation (cyclic test every 20 s)
Signalling	
On/off (battery switch-off)	External NO contact (load 12 V DC/5 mA)
Normal mode	Green LED + N/B signal (floating changeover contact N/B in position N) ²⁾
Buffer or battery mode (battery supplies load on its own, or in addition to PS in event of overload)	Yellow LED + N/B signal (floating changeover contact N/B in position N) ²⁾
Alarm (buffer readiness missing or pre-warning at < 20.4 V battery voltage)	Red LED + alarm signal (floating changeover contact for alarm) ²⁾
Safety	
Galvanic isolation primary/secondary	No
Protective class	Class III (ext. circuit and power supply unit: SELV voltage acc. to EN 60950 is required)
TÜV test/CE marking	Yes/yes
UL/cUL (CSA) approval ³⁾	Yes, UL/cUL recognized (UL 1950), File E172952
Degree of protection (EN 60529)	IP20
EMC	
Interference emission	EN 55022 Class B
Interference immunity	EN 61000-6-2
Ambient conditions	
Ambient temperature range in operation	0 to +60 °C with natural convection
Transportation and storage temperature range	-25 to +85 °C
Humidity rating	H acc. to DIN 40040: relative humidity up to 75 % as mean value, 95 % on 30 days/year, no condensation
Mechanical specifications	
Input connections ⁴⁾ L+, M	2 screw-type terminals for 0.5 to 10 mm ² single-core/finely stranded
Output connections ⁴⁾ L+, M	2 screw-type terminals for 0.5 to 10 mm ² single-core/finely stranded
Battery connections +/-	2 screw-type terminals for 0.5 to 10 mm ² single-core/finely stranded
Signals On/Off, N/B, alarm, shield connections	9 screw-type terminals for 0.5 to 2,5 mm ² single-core/finely stranded
Dimensions (W x H x D) in mm, approx.	220 x 130 x 65
Approx. weight	1.2 kg
Mounting	Snap-mounting on DIN rail EN 50022-35x7.5 or on SITOP power 90° mounting bracket

1) Reliable power supplies are the single-phase SITOP power 10 A and 20 A and the three-phase SITOP power 10 A to 40 A if their output voltage is set between 25 V and 25.5 V DC. The single-phase SITOP power supply units 2 A to 10 A with Order Nos. 6EP13...-1... are not reliable.

2) Permissible contact rating: 60 V DC/1 A or 30 V AC/1 A.

3) Approval only in combination with battery module 7 Ah (6EP1935-6ME01).

4) Both L+ and M connections are electrically connected within the device, and a differentiation of the input/output connections on the device is therefore unnecessary.

SITOP power · Standard 24 V Uninterruptible power supplies

Battery module 1.2 Ah

Overview



- Battery module for DC UPS module 6 A
- Contains two maintenance-free, sealed lead-acid batteries from the same batch fitted in a holder and connected in series
- Completely prewired with battery fuse holder and terminals
- Low self-discharge rate of approx. 3 % per month (at +20 °C)

Technical specifications

Battery module 1.2 Ah

6EP1 935-6MC01

Maintenance-free lead-acid batteries¹⁾

Order No.	6EP1 935-6MC01
Battery type, charging current/charging voltage	Maintenance-free lead-acid batteries ¹⁾
Recommended end-of-charge voltage (standby use)	
• For +25 °C battery temperature	27.0 V DC
• For other battery temperatures	27.8 V for +10 °C; 27.3 V for +20 °C; 26.8 V for +30 °C; 26.7 V for +35 °C; 26.6 V for +40 °C
Recommended charging current	Max. 0.3 A
Protection	
Short-circuit protection	Battery fuse 15 A/32 V (FK2 flat fuse + holder)
Battery protection	Valve control
Safety	
Protective class	Class III
UL/cUL (CSA) approval	UL/cUL recognized (UL1778, CSA 22.2 No. 107.1-95), File E219627
Degree of protection (EN 60529)	IP00
Operating specifications	
Ambient temperature range	+5 to +40 °C
Transportation and storage temperature range	-20 to +50 °C
Self-discharge rate	Approx. 3 % per month at a battery temperature of 20 °C (increased value at higher temperature)
Service life	
The service life of the chemical lead-acid batteries (reduction to 50 % of original capacity) depends on the battery temperature as follows:	
At +20 °C	Approx. 4 years
At +25 °C	Approx. 3.5 years
At +30 °C	Approx. 3 years
At +35 °C	Approx. 2.5 years
At +40 °C	Approx. 2 years
At +45 °C	Approx. 1.5 years
At +50 °C	Approx. 1 year
Mechanical specifications	
Connection	1 terminal each for 0.08 to 2.5 mm ² for + BAT and - BAT
Supplied accessories	Accessory pack with FK2 fuse 15 A
Dimensions (W x H x D) in mm	Approx. 96 x 106 x 108
Weight	Approx. 2 kg
Mounting	Snap-mounting on DIN rail EN 50022-35x15/7.5 or keyhole mounting for hanging in M4 screws

1) For storage, installation and operation of the lead-acid batteries, the appropriate DIN/VDE regulations or the country-specific directives (e.g. VDE 0510 Part 2/EN 50272-2) must be observed. The battery location must be sufficiently ventilated, potential ignition sources must be at least 50 cm away.

SITOP power · Standard 24 V Uninterruptible power supplies

Battery module 2.5 Ah

Overview



- High-temperature battery for DC UPS module 6 A and 15 A
- Contains two maintenance-free, sealed chemical lead-acid batteries from the same batch fitted in a holder and connected in series
- Completely prewired with battery fuse holder and terminals
- Low self-discharge rate of approx. 3 % per month (at +20 °C)

Technical specifications

Order No.	Battery module 2.5 Ah 6EP1 935-6MD31
Battery type, charging current/ charging voltage	Maintenance-free chemical lead-acid batteries ¹⁾
Recommended end-of-charge voltage (standby use)	27.7 V DC
• For +25 °C battery temperature	27.7 V DC
• For other battery temperatures	29.0 V for -10 °C; 28.6 V for 0 °C; 28.3 V for +10 °C; 27.9 V for +20 °C; 27.5 V for +30 °C; 27.2 V for +40 °C; 26.8 V for +50 °C; 26.4 V for +60 °C
Recommended charging current	Max. 5 A
Protection	
Short-circuit protection	Battery fuse 15 A/32 V (FK2 flat fuse + holder)
Battery protection	Valve control
Safety	
Protective class	Class III
UL/cUL (CSA) approval	UL/cUL recognized (UL1778, CSA 22.2 No. 107.1-95), File E219627
Degree of protection (EN 60529)	IP00
Operating specifications	
Ambient temperature range	-40 to +60 °C with natural convection
Transportation and storage temper- ature range	-40 to +60 °C
Self-discharge rate	Approx. 3 % per month at a battery temperature of 20 °C (increased value at higher tem- perature)
Service life	
The service life of the chemical lead-acid batteries (reduction to 80 % of original capacity) depends on the battery temperature as follows:	
At +15 °C	Approx. 19 years
At +20 °C	Approx. 13 years
At +25 °C	Approx. 9 years
At +30 °C	Approx. 7 years
At +35 °C	Approx. 5 years
At +40 °C	Approx. 3 years
At +45 °C	Approx. 2 years
At +50 °C	Approx. 1.5 years
At +60 °C	Approx. 1 year
Mechanical specifications	
Connection	1 terminal each for 0.08 to 2.5 mm ² for + BAT and - BAT
Supplied accessories	Accessory pack with FK2 fuse 15 A
Dimensions (W x H x D) in mm	Approx. 265 x 151 x 91
Weight	Approx. 3.8 kg
Mounting	Snap-mounting on DIN rail EN 50022-35x15/7.5 or keyhole mounting for hanging in M4 screws

1) For storage, installation and operation of the lead-acid batteries, the appropriate DIN/VDE regulations or the country-specific directives (e.g. VDE 0510 Part 2/EN 50272-2) must be observed. The battery location must be sufficiently ventilated, potential ignition sources must be at least 50 cm away.

SITOP power · Standard 24 V Uninterruptible power supplies

Battery module 3.2 Ah

Overview



- Battery module for DC UPS module 6 A and 15 A
- Contains two maintenance-free, sealed lead-acid batteries from the same batch fitted in a holder and connected in series
- Includes battery fuse holder and terminals
- Low self-discharge rate of approx. 3 % per month (at +20 °C)

Technical specifications

Battery module 3.2 Ah

6EP1 935-6MD11

Maintenance-free, sealed lead-acid batteries¹⁾

Order No.	6EP1 935-6MD11
Battery type, charging current/charging voltage	Maintenance-free, sealed lead-acid batteries ¹⁾
Recommended end-of-charge voltage (standby use)	
• For +25 °C battery temperature	27.0 V DC
• For other battery temperatures	27.8 V for +10 °C; 27.3 V for +20 °C; 26.8 V for +30 °C; 26.7 V for +35 °C; 26.6 V for +40 °C
Recommended charging current	Max. 0.8 A
Protection	
Short-circuit protection	Battery fuse 15 A/32 V (FK2 flat fuse + holder)
Battery protection	Valve control
Safety	
Protective class	Class III
UL/cUL (CSA) approval	UL/cUL recognized (UL1778, CSA 22.2 No. 107.1-95), File E219627
Degree of protection (EN 60529)	IP00
Operating specifications	
Ambient temperature range	+5 to +40 °C with natural convection
Transportation and storage temperature range	-20 to +50 °C
Self-discharge rate	Approx. 3 % per month at a battery temperature of 20 °C (increased value at higher temperature)
Service life	
The service life of the chemical lead-acid batteries (reduction to 50 % of original capacity) depends on the battery temperature as follows:	
At +20 °C	Approx. 4 years
At +25 °C	Approx. 3.5 years
At +30 °C	Approx. 3 years
At +35 °C	Approx. 2.5 years
At +40 °C	Approx. 2 years
At +45 °C	Approx. 1.5 years
At +50 °C	Approx. 1 year
Mechanical specifications	
Connection	1 terminal each for 0.08 to 2.5 mm ² for + BAT and - BAT
Supplied accessories	Accessory pack with FK2 fuse 15 A
Dimensions (W x H x D) in mm	Approx. 190 x 151 x approx. 82
Weight	Approx. 3.2 kg
Mounting	Snap-mounting on DIN rail EN 50022-35x15/7.5 or keyhole mounting for hanging in M4 screws

¹⁾ For storage, installation and operation of the lead-acid batteries, the appropriate DIN/VDE regulations or the country-specific directives (e.g. VDE 0510 Part 2/EN 50272-2) must be observed. The battery location must be sufficiently ventilated, potential ignition sources must be at least 50 cm away.

SITOP power · Standard 24 V Uninterruptible power supplies

Battery module 7 Ah

Overview



- Battery for DC UPS module 6 A and 15 A and DC UPS module 40 A
- Contains two maintenance-free, sealed lead-acid batteries from the same batch fitted in a holder and connected in series
- Completely prewired with battery fuse holder and terminals
- Accessory pack with FK2 spare fuses 15 A and 20 A
- Low self-discharge rate of approx. 3 % per month (at +20 °C)

Technical specifications

		Battery module 7 Ah
Order No.		6EP1 935-6ME21
Battery type, charging current/ charging voltage		Maintenance-free, sealed lead-acid batteries ¹⁾
Recommended end-of-charge voltage (standby use)		
• For +25 °C battery temperature	27.0 V DC	
• For other battery temperatures	27.8 V for +10 °C; 27.3 V for +20 °C; 26.8 V for +30 °C; 26.7 V for +35 °C; 26.6 V for +40 °C	
Recommended charging current	Max. 1.75 A	
Protection		
Short-circuit protection	Battery fuse 15 A/32 V (FK2 flat fuse + holder)	
Battery protection	Valve control	
Safety		
Protective class	Class III	
UL/cUL (CSA) approval	UL/cUL recognized (UL1778, CSA 22.2 No. 107.1-95), File E219627	
Degree of protection (EN 60529)	IP00	
Operating specifications		
Ambient temperature	+5 to +40 °C	
Transportation and storage temperature range	-20 to +50 °C	
Self-discharge rate	Approx. 3 % per month at a battery temperature of 20 °C	
Service life		
The service life of the chemical lead-acid batteries (reduction to 50 % of original capacity) depends on the battery temperature as follows:		
At +20 °C	Approx. 4 years	
At +25 °C	Approx. 3.5 years	
At +30 °C	Approx. 3 years	
At +35 °C	Approx. 2.5 years	
At +40 °C	Approx. 2 years	
At +45 °C	Approx. 1.5 years	
At +50 °C	Approx. 1 year	
Mechanical specifications		
Connection	1 terminal each for 0.08 to 4 mm ² for + BAT - BAT	
Supplied accessories	Accessory pack with FK2 spare fuses 15 A and 20 A	
Dimensions (W x H x D) in mm	Approx. 186 x 168 x 121	
Weight	Approx. 6.0 kg	
Mounting	Can be screwed on level surface (Keyhole mounting for hanging in M4 screws)	

1) For storage, installation and operation of the lead-acid batteries, the appropriate DIN/VDE regulations or the country-specific directives (e.g. VDE 0510 Part 2/EN 50272-2) must be observed. The battery location must be sufficiently ventilated, potential ignition sources must be at least 50 cm away.

SITOP power · Standard 24 V Uninterruptible power supplies

Battery module 12 Ah

Overview



- Battery for DC UPS module 6 A and 15 A and DC UPS module 40 A
- Contains two maintenance-free, sealed lead-acid batteries from the same batch fitted in a holder and connected in series
- Completely prewired with battery fuse holder and terminals
- Accessory pack with FK2 spare fuses 15 A and 20 A
- Low self-discharge rate of approx. 3 % per month (at +20 °C)

Technical specifications

Battery module 12 Ah

6EP1 935-6MF01

Battery type, charging current/ charging voltage

Maintenance-free, sealed lead-acid batteries¹⁾

Recommended end-of-charge voltage (standby use)

- For +25 °C battery temperature 27.0 V DC
- For other battery temperatures 27.8 V for +10 °C;
27.3 V for +20 °C;
26.8 V for +30 °C;
26.7 V for +35 °C;
26.6 V for +40 °C

Recommended charging current Max. 3 A

Protection

Short-circuit protection	Battery fuse 15 A/32 V (FK2 flat fuse + holder)
Battery protection	Valve control

Safety

Protective class	Class III
UL/cUL (CSA) approval	UL/cUL recognized (UL1778, CSA 22.2 No. 107.1-95), File E219627

Degree of protection (EN 60529) IP00

Operating specifications

Ambient temperature	+5 to +40 °C
Transportation and storage temperature range	-20 to +50 °C
Self-discharge rate	Approx. 3 % per month at a battery temperature of 20 °C

Service life

The service life of the chemical lead-acid batteries (reduction to 50 % of original capacity) depends on the battery temperature as follows:

At +20 °C	Approx. 4 years
At +25 °C	Approx. 3.5 years
At +30 °C	Approx. 3 years
At +35 °C	Approx. 2.5 years
At +40 °C	Approx. 2 years
At +45 °C	Approx. 1.5 years
At +50 °C	Approx. 1 year

Mechanical specifications

Connection	1 terminal each for 0.08 to 4 mm ² for + BAT - BAT
Supplied accessories	Accessory pack with FK2 spare fuses 15 A and 20 A
Dimensions (W x H x D) in mm	Approx. 253 x 118 x 121
Weight	Approx. 9.0 kg
Mounting	Can be screwed on level surface (Keyhole mounting for hanging in M4 screws)

1) For storage, installation and operation of the lead-acid batteries, the appropriate DIN/VDE regulations or the country-specific directives (e.g. VDE 0510 Part 2/EN 50272-2) must be observed. The battery location must be sufficiently ventilated, potential ignition sources must be at least 50 cm away.

SITOP power Alternative voltages

10



- 10/2 SITOP power flexi 120 W
- 10/2 SITOP power dual 15 V
- 10/2 SITOP modular 48 V/20 A



SITOP power

Alternative voltages

Overview

SITOP power flexi 120 W



SITOP power dual 15 V



SITOP modular 48 V/20 A



Application

The power supply unit with adjustable output voltage from 3 V to 52 V; suitable for all applications where a special voltage deviating from 24 V is required.

The industry-standard power supply unit with two 15 V outputs which can be connected in parallel or in series; can be used, for example, for supplying electronic loads with ± 15 V.

The modular 48 V power supply unit with three-phase wide-range input for powerful loads which are powered by twice the voltage instead of the usual 24 V.

Technical specifications

Power supply, type	3 to 52 V/2 to 10 A	2 x 15 V/3.5 A	48 V/20 A
Order No.	6EP1 353-2BA00	6EP1 353-0AA00	6EP1 457-3BA00
Input	Single-phase AC	Single-phase AC	Three-phase AC
Rated voltage V_{in} rated	120/230 V AC	120 to 230 V AC	400 to 500 V 3 AC
Voltage range	Settable using wire jumper 85 to 132 V/170 to 264 V AC	wide-range input 93 to 264 V AC	wide-range input 320 to 550 V (startup from $V_{in} > 340$ V)
Overvoltage strength	$2.3 \times V_{in}$ rated, 1.3 ms	Surge voltage acc. to EN 61000-6-2 Table 4	$2.3 \times V_{in}$ rated, 1.3 ms
Mains buffering at I_{out} rated	> 10 ms at $V_{in} = 93/187$ V ($P_{out} = 120$ W)	$> 10/40$ ms at $V_{in} = 120/187$ V	> 6 ms at $V_{in} = 400$ V
Rated line frequency; range	50/60 Hz, 47 to 63 Hz	50/60 Hz; 47 to 63 Hz	50/60 Hz; 47 to 63 Hz
Rated current I_{in} rated	2.2/0.9 A	1.9 to 1.15 A	2.2 A ($V_{in} = 400$ V)
Inrush current limitation (+ 25 °C)	< 32 A	< 30 A, typ. 3 ms	< 70 A
I^2t	< 0.8 A ² s	< 3 A ² s	< 2.8 A ² s
Integrated line-side fuse	T3.15 A/250 V (not accessible)	T4 A/250 V (not accessible)	none
Recommended circuit-breaker (IEC 898) in mains supply line	From 6 A Characteristic C	From 10 A Characteristic C or from 16 A Characteristic B	Required: 3-pole coupled circuit-breaker 10 to 16 A Char. C or motor circuit-breaker 3RV1021-1DA10, setting 3 A
Output	Stabilized, floating direct voltage	Stabilized, floating direct voltage	Stabilized, floating direct voltage
Rated voltage V_{out} rated	3 to 52 V DC	2 x 15 V DC	48 V DC
Total tolerance	± 1 %	± 2 %	± 3 %
• Stat. mains compensation	Approx. 0.1 %	Approx. 0.2 %	Approx. ± 0.1 %
• Stat. load compensation	Approx. 0.2 %	Approx. 0.2 %	Approx. ± 0.2 %
Sense line connection	Yes, maximum voltage control 0.5 V per line	-	-
Residual ripple (clock frequency: approx. 50 kHz)	< 50 mV _{pp}	< 50 mV _{pp} (typ. 20 mV _{pp})	< 100 mV _{pp}
Spikes (bandwidth: 20 MHz)	< 100 mV _{pp}	< 150 mV _{pp} (typ. 150 mV _{pp})	< 200 mV _{pp}
Setting range	3 to 52 V, via potentiometer or analog control voltage signal 0 to 2.5 V	14.5 to 17 V	42 to 56 V (max. 960 W)
Status display	Green LED for 24 V O.K.	Green LED for $V_{out} > 10$ V (summation display)	Green LED for 48 V O.K.
Signalling	Power Good via relay contact, current monitor signal 0 to 2.5 V	-	possible using signalling module (6EP1 961-3BA10)
Power ON/OFF behavior	No overshoot of V_{out} (soft start)	Overshoot of $V_{out} < 3$ %	No overshoot of V_{out} (soft start)
Starting delay/voltage rise	< 3 s/typ. 80 ms	< 1 s	< 2.5 s/ < 500 ms
Rated current I_{out} rated	2 to 10 A (max. 120 W)	2 x 3.5 A	20 A
Current range	0 to 10 A (max. 120 W)	2 x 0 to 3.5 A	0 to 20 A
• up to + 45 °C	0 to 10 A (max. 120 W)	2 x 0 to 2.5 A	0 to 20 A
• up to + 60 °C	0 to 10 A (max. 120 W)		

Continued on page 10/3.

Technical specifications (continued)

Power supply, type	3 to 52 V/2 to 10 A	2 x 15 V/3.5 A	48 V/20 A
Order No.	6EP1 353-2BA00	6EP1 353-0AA00	6EP1 457-3BA00
Dyn. V/I with			
• Starting on short circuit	Constant current 2 to 10 A		Constant current approx. 23 A
• Short-circuit in operation	Constant current 2 to 10 A		typ. 60 A for 25 ms
Parallel connection for increased output	Yes, 2	Yes, 2	Yes, 2
Efficiency			
Efficiency at $V_{out\ rated}$, $I_{out\ rated}$	Approx. 84 % (at 24 V/5 A)	Approx. 80 %	Approx. 90 %
Power loss at $V_{out\ rated}$, $I_{out\ rated}$	Approx. 23 W (at 24 V/5 A)	Approx. 27 W	Approx. 106 W
Protection and monitoring			
Output overvoltage protection	Yes, acc. to EN 60950	Yes, acc. to EN 60950	Yes, acc. to EN 60950
Current limitation	2 to 10 A, adjustable via potentiometer or analog control voltage signal 0 to 2.5 V	Limit point < 4.9 A; switch-off point < 6 A	typ. 23 A
Short-circuit protection	Electronic current limiting (2 to 10 A) in the range 3 to 12 V or power limiting (120 W) in the range 12 to 52 V	Electronic shutdown, automatic restart	Choice of stabilized current characteristic approx. 23 A or latching shutdown
Overload/short-circuit indicator	Red LED for current or power limiting	-	Yellow LED for "overload", red LED for "latching shutdown"
Safety			
Galvanic isolation primary/ secondary	Yes, SELV output voltage V_{out} acc. to EN 60950 and EN 50178	Yes, SELV output voltage V_{out} acc. to EN 60950	Yes, SELV output voltage V_{out} acc. to EN 60950
Protective class	Class I	Class I	Class I
Discharge current	< 3.5 mA	< 3.5 mA	< 3.5 mA
TÜV test	Yes	-	Yes
CE marking	Yes	Yes	Yes
UL/cUL (CSA) approval	Yes, cULus listed (UL 508, CSA 22.2 No. 14-M91), File E143289	Yes, cULus listed (UL 508, CSA 22.2 No. 14-M91), File E179336	Yes, cULus listed (UL 508, CSA 22.2 No. 14-M95), File E197259
FM approval	-	-	-
Appr. for use in marine vessels	-	-	-
Degree of protection (EN 60529)	IP20	IP20	IP20
EMC			
Interference emission	EN 55022 Class B	EN 55011 Class A	EN 55022 Class B
Line harmonics limitation	EN 61000-3-2	-	EN 61000-3-2
Interference immunity	EN 61000-6-2	EN 61000-6-2	EN 61000-6-2
Operating specifications			
Ambient temperature range	0 to +60 °C with natural convection	0 to +60 °C with natural convection, derating above +45 °C	0 to +60 °C with natural convection
Transportation and storage temperature range	-25 to +85 °C	-40 to +70 °C	-25 to +85 °C
Humidity rating	Climatic class 3K3 acc. to EN 60721	Climatic class 3K3 acc. to EN 60721	Climatic class 3K3 acc. to EN 60721
Mechanical specifications			
Connections			
• Mains input L1, N, PE	One screw-type terminal each for 0.5 to 2.5 mm ² single-core/finely stranded	One screw-type terminal each for 0.5 to 2.5 mm ² single-core/finely stranded	One screw-type terminal each for 0.2 to 4 mm ² single-core/finely stranded (L1, L2, L3, PE)
• Output	One screw-type terminal for 0.5 to 2.5 mm ² (L+) and 2 screw-type terminals for 0.5 to 2.5 mm ² (M)	One screw-type terminal for 0.5 to 2.5 mm ² (P15_1, GND1, GND2) and 2 screw-type terminals for 0.5 to 2.5 mm ² (P15_2)	2 screw-type terminals each for 0.33 to 10 mm ² (+, -)
• Messages, control inputs	One screw-type terminal each for 0.14 to 1.5 mm ²	-	-
Dimensions (W x H x D) in mm	75 x 125 x 125	75 x 125 x 125	240 x 125 x 125
Weight approx.	Approx. 0.9 kg	Approx. 0.75 kg	3.2 kg
Mounting	Snap-mounting on DIN rail EN 50022-35x15/7.5	Snap-mounting on DIN rail EN 50022-35x15/7.5	Snap-mounting on DIN rail EN 50022-35x15/7.5
Accessories	-	-	Signalling module (6EP1961-3BA10)

SITOP power

Alternative voltages

Notes

10



SITOP power AS interface power supplies

11



11/2 The IP65 version
11/2 The IP20 version



SITOP power AS interface power supplies

Single-phase AS interface power supplies,
stabilized

Overview

The IP65 version



The IP20 version



Application

The AS interface power supply unit with IP65 degree of protection for any mounting position is particularly suitable for use in extremely harsh environments. Thanks to the 24 V DC input voltage it is ideally suitable for use together with a proven SITOP power 24 V standard power supply unit.

This AS interface power supply unit with its wide-range input of 93 to 264 V AC and 110 to 350 V DC can be universally used in all typical power supply networks. With limitation of the input current harmonics acc. to EN 61000-3-2; with SIMATIC S7-300 design.

Technical specifications

Power supply, type	2.4 A	7 A
Order No.	6EP1 632-1AL01	6EP1 354-1AL01
Input	DC voltage	Single-phase AC
Rated voltage $V_{in \text{ rated}}$	24 V DC	120 to 230 V AC wide-range input 93 to 264 V AC/110 to 350 V DC
Voltage range	20.4 to 28.8 V DC	
Overvoltage strength	35 V DC for max. 500 ms	$2.3 \times V_{in \text{ rated}}$, 1.3 ms
Mains buffering at $I_{out \text{ rated}}$	> 10 ms	> 20 ms at $V_{in} = 93/187 \text{ V}$
Rated line frequency; range	-	0/50/60 Hz; 47 to 63 Hz
Rated input current $I_{in \text{ rated}}$	3.6 A	2.2 to 1.2 A
Inrush current limitation (+25 °C)	-	< 20 A, < 3 ms
I^2t	-	< 1.5 A ² s
Integrated line-side fuse	T 6.3 A (not accessible)	T 6.3 A (not accessible)
Recommended circuit-breaker (IEC 898) in mains supply line	From 10 A, Characteristic C or from 6 A, Characteristic D	From 16 A, Characteristic C
Output	Stabilized, floating direct voltage acc. to AS interface specifications	Stabilized, floating direct voltage acc. to AS interface specification
Rated voltage $V_{out \text{ rated}}$	30 V DC	30 V DC
Total tolerance	29.5 V to 31.6 V DC	29.5 to 31.6 V DC
Residual ripple	< 300 mV _{pp}	< 300 mV _{pp}
Spikes	< 50 mV _{pp}	< 50 mV _{pp}
Status display	Green LED	Green LED
Rated current $I_{out \text{ rated}}$	2.4 A	7 A
Efficiency / power loss		
Efficiency at $V_{out \text{ rated}}$, $I_{out \text{ rated}}$	> 81%	> 85%
Power loss at $V_{out \text{ rated}}$, $I_{out \text{ rated}}$	< 17 W	< 37 W
Protection and monitoring functions		
Output overvoltage protection	-	Yes
Current limiting	From approx. 2.9 A	From approx. 7.4 A
Short-circuit protection	Constant current characteristic approx. 2.9 A	Constant current characteristic approx. 7.4 A

Continued on page 11/3.

SITOP power AS interface power supplies

Single-phase AS interface power supplies,
stabilized

Power supply, type	2.4 A	7 A
Order No.	6EP1 632-1AL01	6EP1 354-1AL01
Safety		
Galvanic isolation primary/secondary	Yes, SELV output voltage V_{out} acc. to EN 60950	Yes, SELV output voltage V_{out} acc. to EN 60950
Protective class	Class I	Class I
Degree of protection (EN 60529)	IP65 ¹⁾	IP20
CE marking	Yes	Yes
UL/cUL (CSA) approval	UL (UL 508), File 179336, CSA (CSA 22.2 No. 14-95)	cULus (UL 508, CSA 22.2 No.14-M91), File E143289
EMC		
Interference emission	EN 55022 Class B	EN 55022 Class B
Line harmonics limitation	Not applicable	EN 61000-3-2
Interference immunity	EN 61000-6-2	EN 61000-6-2
Operating specifications		
Ambient temperature range	-25 to +55 °C	0 to +55 °C
Transportation and storage temperature range	-25 to +85 °C	-25 to +85 °C
Humidity rating	Climatic class 3K3 acc. to EN 60721, no condensation	Climatic class 3K3 acc. to EN 60721, no condensation
Mechanical specifications		
Input connections	Circular connector 0.5 to 2.5 mm ² ¹⁾²⁾	One screw-type terminal each for 0.5 to 2.5 mm ² single-core/finely stranded
Output connections AS i +	500 mm three-core cable AWG 14 ¹⁾	3 screw-type terminals for 0.5 to 2.5 mm ²
Output connections AS i -	500 mm three-core cable AWG 14 ¹⁾	3 screw-type terminals for 0.5 to 2.5 mm ²
Output connections Ground	500 mm three-core cable AWG 14 ¹⁾	2 screw-type terminals for 0.5 to 2.5 mm ²
Dimensions (W x H x D) in mm	224 x 80 x 57	200 x 125 x 135
Weight approx.	1.0 kg	1.8 kg
Mounting	Wall mounting, any mounting position	Snap-mounting on DIN rail EN 50022-35x15 mm and S7 rail
Accessories	6-pin circular input connector (6ES5 760-2CA11) and AS interface coupling module PG (3RG9 220-0AA00)	-

1) In IP20 degree of protection with screw-type terminals on request.

2) The counterpart must be ordered separately (not included in the scope of delivery); see Accessories.

SITOP power

AS interface power supplies

Notes



SITOP power Customized

12



12/2 Description
12/3 Specification sheet



SITOP power Customized

Overview

Our tried and tested standard power supplies cannot, of course, be suitable for absolutely every application. Does your application require a voltage level other than 24 V, or is a 19" or open-frame version necessary, or are the environmental conditions of your system sometimes outside the normal ranges? We offer the possibility for optimum adaptation to your application-specific requirements.

Thanks to the experience and know-how of our development team, we are able to offer you a tailored solution by applying a modular power supply concept. Your specific requirements can be fulfilled by modifying existing equipment or by complete new developments on the basis of pre-developed standard components. Your advantages are evident:

- Adaptation of the power supply to your application, and not vice versa as in the past
- Highly flexible electrical parameters
- AC or DC input
- Several output voltages possible
- High reliability through use of standard components
- Variability with respect to design requirements
- Adaptable mechanical system.

You therefore benefit from the competence of mass production together with a maximum of development reliability and quality. Further decisive criteria for the success of your application are:

- High availability thanks to fast development cycles
- Short time span between development and start of series production thanks to tried and tested launch procedures
- Prices in line with the market.

Our customized solutions are currently in use in many sectors of mechanical engineering, automation engineering, vehicle electronics, equipment design and industrial measurement engineering, among others.

Our product range is open to any application. If you are interested and require further information, please copy the following page, fill in the parameters of your specific requirement and fax it to the stated number.

Form for inquiry is also available at:

http://intra1.nbgm.siemens.de/extern/spiegeln/sitop/html_76/formular.htm

You can fill it out right on the screen and send it to us immediately. We will contact you without delay.



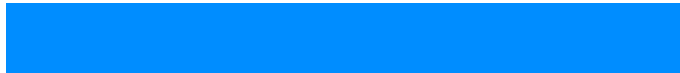

FAX reply

Specification sheet for customized power supplies

Recipient:

SIEMENS AG
A&D SE PS 1
Würzburger Straße 121
90766 Fürth

FAX: 0911 750-9991

Sender:

Company: _____

Department: _____

Name: _____

City: _____

FAX: _____

Phone: _____

Application:

Electrical requirements:

Input voltage: V_{in} : _____ Tolerance ΔV_{in} : _____

Frequency: f_{in} : _____ Tolerance Δf_{in} : _____

Mains buffering time: T_{in} : _____

Output voltage: V_{out1} : _____ V_{out2} : _____ V_{out3} : _____ V_{out4} : _____

Output current: I_{out1} : _____ I_{out2} : _____ I_{out3} : _____ I_{out4} : _____

Other: _____

Mechanical requirements:

Design/dimensions: _____ Enclosure: _____
(attach drawing if necessary)

Connections: _____ Other: _____

General requirements:

Efficiency: _____

Ambient temperature: _____ Signalling: _____

Standards: EN 60950 UL cUL (CSA) _____

EN 61000-6-1/2 EN 61000-6-3/4

Quantity/year: _____ Delivery: _____

Price expectations: _____

Remarks: _____





- 13/2 LOGO!Power 5 V
- 13/4 LOGO!Power 12 V
- 13/6 LOGO!Power 15 V
- 13/8 LOGO!Power 24 V



LOGO!Power 5 V

Overview

LOGO!Power 5 V



Application

LOGO!Power supplies are primary switched-mode power supplies that are optimized to the LOGO! logic modules in terms of functionality and design. With the wide input range of 85 V to 264 V AC, radio interference level B and assembly option in built-in miniature distribution boards, they can be used universally in a diverse range of applications in the low-end performance range.

Technical specifications

Power supply, type	5 V/3 A	5 V/6.3 A
Order No.	6EP1 311-1SH02	6EP1 311-1SH12
Input	Single-phase AC	Single-phase AC
Rated voltage $V_{in \text{ rated}}$	100 to 240 V AC	100 to 240 V AC
Voltage range	wide-range input 85 to 264 V AC	wide-range input 85 to 264 V AC
Overshoot strength	$2.3 \times V_{in \text{ rated}}/1.3 \text{ ms}$	$2.3 \times V_{in \text{ rated}}/1.3 \text{ ms}$
Mains buffering at $I_{out \text{ rated}}$	> 40 ms at $V_{in} = 187 \text{ V}$	> 40 ms at $V_{in} = 187 \text{ V}$
Rated line frequency; range	50/60 Hz; 47 to 63 Hz	50/60 Hz; 47 to 63 Hz
Rated current $I_{in \text{ rated}}$	0.36 to 0.22 A	0.71 to 0.37 A
Inrush current limitation (+25 °C)	< 15 A	< 30 A
I^2t	< 0.8 A ² s	< 3 A ² s
Integrated line-side fuse	Internal	Internal
Recommended circuit-breaker (IEC 898) in mains supply line	From 16 A Characteristic B or from 10 A Characteristic C	From 16 A Characteristic B or from 10 A Characteristic C
Output	Stabilized, floating direct voltage	Stabilized, floating direct voltage
Rated voltage $V_{out \text{ rated}}$	5 V DC	5 V DC
Total tolerance, static	± 3 %	± 3 %
• Static mains compensation	Approx. 0.2 %	Approx. 0.1 %
• Static load compensation	Approx. 1.5 %	Approx. 2 %
Residual ripple (clock frequency approx. 90 kHz)	< 100 mV _{pp}	< 100 mV _{pp}
Spikes (bandwidth approx. 20 MHz)	< 100 mV _{pp}	< 100 mV _{pp}
Setting range	4.6 to 5.4 V	4.6 to 5.4 V
Status display	Green LED for output voltage OK	Green LED for output voltage OK
Power ON/OFF behavior	No overshoot of V_{out} (soft start)	No overshoot of V_{out} (soft start)
Starting delay/voltage rise	< 0.5 s/typ. 15 ms	< 0.5 s/typ. 10 ms
Rated current $I_{out \text{ rated}}$	3 A	6.3 A
Current range up to +55 °C	0 to 3 A	0 to 6.3 A
Parallel connection for increased output	Yes	Yes

Continued on page 13/3.

Power supply, type	5 V/3 A	5 V/6.3 A
Order No.	6EP1 311-1SH02	6EP1 311-1SH12
Efficiency		
Efficiency at $V_{out\ rated}$, $I_{out\ rated}$	typ. 76 %	typ. 83 %
Power loss at $V_{out\ rated}$, $I_{out\ rated}$	typ. 5 W	typ. 6 W
Control		
Dyn. mains compensation ($V_{in\ rated} \pm 15\%$)	< 0.2 % V_{out}	< 0.2 % V_{out}
Dyn. load compensation (I_{out} : 10/90/10 %)	$\pm 4\%$ V_{out}	$\pm 6.5\%$ V_{out}
Settling time		
• Load step from 10 to 90 %	typ. 20 ms	typ. 20 ms
• Load step from 90 to 10 %	typ. 20 ms	typ. 20 ms
Protection and monitoring		
Current limitation	typ. 3.8 A	typ. 8.2 A
Short-circuit protection	Stabilized current characteristic	Stabilized current characteristic
RMS sustained short-circuit current	< 5 A	< 10 A
Overload/short-circuit indicator	-	-
Safety		
Galvanic isolation primary/secondary	Yes, SELV output voltage V_{out} acc. to EN 60950 and EN 50178	Yes, SELV output voltage V_{out} acc. to EN 60950 and EN 50178
Protective class	Class II (without PE conductor)	Class II (without PE conductor)
CE marking	Yes	Yes
UL/cUL (CSA) approval	Yes, cULus listed (UL 508, CSA 22.2 No. 14-M95), File E197259; cURus recognized (UL 60950, CSA 22.2 No. 60950), File E151273	Yes, cULus listed (UL 508, CSA 22.2 No. 14-M95), File E197259; cURus recognized (UL 60950, CSA 22.2 No. 60950), File E151273
FM approval	Yes, Class I Div. 2, Group A, B, C, D T4	Yes, Class I Div. 2, Group A, B, C, D T4
Appr. for use in marine vessels	Yes, GL (Germanischer Lloyd)	Yes, GL (Germanischer Lloyd)
Degree of protection (EN 60529)	IP20	IP20
EMC		
Interference emission	EN 55022 Class B	EN 55022 Class B
Line harmonics limitation	Not applicable	Not applicable
Interference immunity	EN 61000-6-2	EN 61000-6-2
Operating specifications		
Ambient temperature range	-20 to +55 °C with natural convection	-20 to +55 °C with natural convection
Transportation and storage temperature range	-40 to +70 °C	-40 to +70 °C
Humidity rating	Climatic class 3K3 acc. to EN 60721, no condensation	Climatic class 3K3 acc. to EN 60721, no condensation
Mechanical specifications		
Mains input connections L1, N	One screw-type terminal each for 0.5 to 2.5 mm ² single- core/finely stranded	One screw-type terminal each for 0.5 to 2.5 mm ² single- core/finely stranded
Connections		
• Output +	2 screw-type terminals each for 0.5 to 2.5 mm ²	2 screw-type terminals each for 0.5 to 2.5 mm ²
• Output -		
Dimensions (W x H x D) in mm	54 x 90 x 55	72 x 90 x 55
Weight	Approx. 0.17 kg	Approx. 0.25 kg
Mounting	Snap-mounting on DIN rail EN 50022-35x7.5/15	Snap-mounting on DIN rail EN 50022-35x7.5/15

LOGO!Power 12 V

Overview



Application

LOGO!Power supplies are primary switched-mode power supplies that are optimized to the LOGO! logic modules in terms of functionality and design. With the wide input range of 85 V to 264 V AC, radio interference level B and assembly option in built-in miniature distribution boards, they can be used universally in a diverse range of applications in the low-end performance range.

Technical specifications

Power supply, type	12 V/1.9 A	12 V/4.5 A
Order No.	6EP1 321-1SH02	6EP1 322-1SH02
Input	Single-phase AC	Single-phase AC
Rated voltage $V_{in \text{ rated}}$	100 to 240 V AC	100 to 240 V AC
Voltage range	wide-range input 85 to 264 V AC	wide-range input 85 to 264 V AC
Oversvoltage strength	$2.3 \times V_{in \text{ rated}}/1.3 \text{ ms}$	$2.3 \times V_{in \text{ rated}}/1.3 \text{ ms}$
Mains buffering at $I_{out \text{ rated}}$	> 40 ms at $V_{in} = 187 \text{ V}$	> 40 ms at $V_{in} = 187 \text{ V}$
Rated line frequency; range	50/60 Hz; 47 to 63 Hz	50/60 Hz; 47 to 63 Hz
Rated current $I_{in \text{ rated}}$	0.53 to 0.3 A	1.13 to 0.61 A
Inrush current limitation (+25 °C)	< 15 A	< 30 A
I^2t	< 0.8 A ² s	< 3 A ² s
Integrated line-side fuse	Internal	Internal
Recommended circuit-breaker (IEC 898) in mains supply line	From 16 A Characteristic B or from 10 A Characteristic C	From 16 A Characteristic B or from 10 A Characteristic C
Output	Stabilized, floating direct voltage	Stabilized, floating direct voltage
Rated voltage $V_{out \text{ rated}}$	12 V DC	12 V DC
Total tolerance, static	± 3 %	± 3 %
• Static mains compensation	Approx. 0.2 %	Approx. 0.1 %
• Static load compensation	Approx. 1.5 %	Approx. 1.5 %
Residual ripple (clock frequency approx. 90 kHz)	< 200 mV _{pp}	< 200 mV _{pp}
Spikes (bandwidth approx. 20 MHz)	< 300 mV _{pp}	< 300 mV _{pp}
Setting range	10.5 to 16.1 V	10.5 to 16.1 V
Status display	Green LED for output voltage OK	Green LED for output voltage OK
Power ON/OFF behavior	No overshoot of V_{out} (soft start)	No overshoot of V_{out} (soft start)
Starting delay/voltage rise	< 0.5 s/typ. 15 ms	< 0.5 s/typ. 10 ms
Rated current $I_{out \text{ rated}}$	1.9 A	4.5 A
Current range up to +55 °C	0 to 1.9 A	0 to 4.5 A
Parallel connection for increased output	Yes	Yes

Continued on page 13/5.

Power supply, type	12 V/1.9 A	12 V/4.5 A
Order No.	6EP1 321-1SH02	6EP1 322-1SH02
Efficiency		
Efficiency at $V_{out\ rated}$, $I_{out\ rated}$	typ. 80 %	typ. 85 %
Power loss at $V_{out\ rated}$, $I_{out\ rated}$	typ. 5 W	typ. 10 W
Control		
Dyn. mains compensation ($V_{in\ rated} \pm 15\%$)	< 0.2 % V_{out}	< 0.2 % V_{out}
Dyn. load compensation (I_{out} : 10/90/10 %)	$\pm 3\%$ V_{out}	$\pm 4.2\%$ V_{out}
Settling time		
• Load step from 10 to 90 %	typ. 20 ms	typ. 20 ms
• Load step from 90 to 10 %	typ. 20 ms	typ. 20 ms
Protection and monitoring		
Current limitation	typ. 2.5 A	typ. 5.9 A
Short-circuit protection	Stabilized current characteristic	Stabilized current characteristic
RMS sustained short-circuit current	< 4 A	< 8 A
Overload/short-circuit indicator	-	-
Safety		
Galvanic isolation primary/secondary	Yes, SELV output voltage V_{out} acc. to EN 60950 and EN 50178	Yes, SELV output voltage V_{out} acc. to EN 60950 and EN 50178
Protective class	Class II (without PE conductor)	Class II (without PE conductor)
CE marking	Yes	Yes
UL/cUL (CSA) approval	Yes, cULus listed (UL 508, CSA 22.2 No. 14-M95), File E197259; cURus recognized (UL 60950, CSA 22.2 No. 60950), File E151273	Yes, cULus listed (UL 508, CSA 22.2 No. 14-M95), File E197259; cURus recognized (UL 60950, CSA 22.2 No. 60950), File E151273
FM approval	Yes, Class I Div. 2, Group A, B, C, D T4	Yes, Class I Div. 2, Group A, B, C, D T4
Appr. for use in marine vessels	Yes, GL, ABS	Yes, GL, ABS
Degree of protection (EN 60529)	IP20	IP20
EMC		
Interference emission	EN 55022 Class B	EN 55022 Class B
Line harmonics limitation	Not applicable	Not applicable
Interference immunity	EN 61000-6-2	EN 61000-6-2
Operating specifications		
Ambient temperature range	-20 to +55 °C with natural convection	-20 to +55 °C with natural convection
Transportation and storage temperature range	-40 to +70 °C	-40 to +70 °C
Humidity rating	Climatic class 3K3 acc. to EN 60721, no condensation	Climatic class 3K3 acc. to EN 60721, no condensation
Mechanical specifications		
Connections		
• Mains input L1, N	One screw-type terminal each for 0.5 to 2.5 mm ² single-core/ finely stranded	One screw-type terminal each for 0.5 to 2.5 mm ² single-core/ finely stranded
• Output +	2 screw-type terminals each for 0.5 to 2.5 mm ²	2 screw-type terminals each for 0.5 to 2.5 mm ²
• Output -		
Dimensions (W x H x D) in mm	54 x 90 x 55	72 x 90 x 55
Weight	Approx. 0.17 kg	Approx. 0.25 kg
Mounting	Snap-mounting on DIN rail EN 50022-35x7.5/15	Snap-mounting on DIN rail EN 50022-35x7.5/15

LOGO!Power 15 V

Overview



Application

LOGO!Power supplies are primary switched-mode power supplies that are optimized to the LOGO! logic modules in terms of functionality and design. With the wide input range of 85 V to 264 V AC, radio interference level B and assembly option in built-in miniature distribution boards, they can be used universally in a diverse range of applications in the low-end performance range.

Technical specifications

Power supply, type	15 V/1.9 A	15 V/4 A
Order No.	6EP1 351-1SH02	6EP1 352-1SH02
Input	Single-phase AC	Single-phase AC
Rated voltage $V_{in \text{ rated}}$	100 to 240 V AC	100 to 240 V AC
Voltage range	wide-range input 85 to 264 V AC	wide-range input 85 to 264 V AC
Oversvoltage strength	$2.3 \times V_{in \text{ rated}}/1.3 \text{ ms}$	$2.3 \times V_{in \text{ rated}}/1.3 \text{ ms}$
Mains buffering at $I_{out \text{ rated}}$	> 40 ms at $V_{in} = 187 \text{ V}$	> 40 ms at $V_{in} = 187 \text{ V}$
Rated line frequency; range	50/60 Hz; 47 to 63 Hz	50/60 Hz; 47 to 63 Hz
Rated current $I_{in \text{ rated}}$	0.63 to 0.33 A	1.24 to 0.68 A
Inrush current limitation (+25 °C)	< 15 A	< 30 A
I^2t	< 0.8 A ² s	< 3 A ² s
Integrated line-side fuse	Internal	Internal
Recommended circuit-breaker (IEC 898) in mains supply line	From 16 A Characteristic B or from 10 A Characteristic C	From 16 A Characteristic B or from 10 A Characteristic C
Output	Stabilized, floating direct voltage	Stabilized, floating direct voltage
Rated voltage $V_{out \text{ rated}}$	15 V DC	15 V DC
Total tolerance, static	± 3 %	± 3 %
• Static mains compensation	Approx. 0.1 %	Approx. 0.1 %
• Static load compensation	Approx. 1.5 %	Approx. 1.5 %
Residual ripple (clock frequency approx. 90 kHz)	< 200 mV _{pp}	< 200 mV _{pp}
Spikes (bandwidth approx. 20 MHz)	< 300 mV _{pp}	< 300 mV _{pp}
Setting range	10.5 to 16.1 V	10.5 to 16.1 V
Status display	Green LED for output voltage OK	Green LED for output voltage OK
Power ON/OFF behavior	No overshoot of V_{out} (soft start)	No overshoot of V_{out} (soft start)
Starting delay/voltage rise	< 0.5 s/typ. 15 ms	< 0.5 s/typ. 10 ms
Rated current $I_{out \text{ rated}}$	1.9 A	4 A
Current range up to +55 °C	0 to 1.9 A	0 to 4 A
Parallel connection for increased output	Yes	Yes

Continued on page 13/7.

Power supply, type	15 V/1.9 A	15 V/4 A
Order No.	6EP1 351-1SH02	6EP1 352-1SH02
Efficiency		
Efficiency at $V_{out\ rated}$, $I_{out\ rated}$	typ. 80 %	typ. 85 %
Power loss at $V_{out\ rated}$, $I_{out\ rated}$	typ. 7 W	typ. 11 W
Control		
Dyn. mains compensation ($V_{in\ rated} \pm 15\%$)	< 0.2 % V_{out}	< 0.2 % V_{out}
Dyn. load compensation (I_{out} : 10/90/10 %)	$\pm 2.8\%$ V_{out}	$\pm 3.3\%$ V_{out}
Settling time		
• Load step from 10 to 90 %	typ. 20 ms	typ. 20 ms
• Load step from 90 to 10 %	typ. 20 ms	typ. 20 ms
Protection and monitoring		
Current limitation	typ. 2.7 A	typ. 5.0 A
Short-circuit protection	Stabilized current characteristic	Stabilized current characteristic
RMS sustained short-circuit current	< 4 A	< 8 A
Overload/short-circuit indicator	-	-
Safety		
Galvanic isolation primary/secondary	Yes, SELV output voltage V_{out} acc. to EN 60950 and EN 50178	Yes, SELV output voltage V_{out} acc. to EN 60950 and EN 50178
Protective class	Class II (without PE conductor)	Class II (without PE conductor)
CE marking	Yes	Yes
UL/cUL (CSA) approval	Yes, cULus listed (UL 508, CSA 22.2 No. 14-M95), File E197259; cURus recognized (UL 60950, CSA 22.2 No. 60950), File E151273	Yes, cULus listed (UL 508, CSA 22.2 No. 14-M95), File E197259; cURus recognized (UL 60950, CSA 22.2 No. 60950), File E151273
FM approval	Yes, Class I Div. 2, Group A, B, C, D T4	Yes, Class I Div. 2, Group A, B, C, D T4
Appr. for use in marine vessels	Yes, GL (Germanischer Lloyd)	Yes, GL (Germanischer Lloyd)
Degree of protection (EN 60529)	IP20	IP20
EMC		
Interference emission	EN 55022 Class B	EN 55022 Class B
Line harmonics limitation	Not applicable	Not applicable
Interference immunity	EN 61000-6-2	EN 61000-6-2
Operating specifications		
Ambient temperature range	-20 to +55 °C with natural convection	-20 to +55 °C with natural convection
Transportation and storage temperature range	-40 to +70 °C	-40 to +70 °C
Humidity rating	Climatic class 3K3 acc. to EN 60721, no condensation	Climatic class 3K3 acc. to EN 60721, no condensation
Mechanical specifications		
Mains input connections L1, N	One screw-type terminal each for 0.5 to 2.5 mm ² single- core/finely stranded	One screw-type terminal each for 0.5 to 2.5 mm ² single- core/finely stranded
Connections		
• Output +	2 screw-type terminals each for 0.5 to 2.5 mm ²	2 screw-type terminals each for 0.5 to 2.5 mm ²
• Output -		
Dimensions (W x H x D) in mm	54 x 90 x 55	72 x 90 x 55
Weight	Approx. 0.17 kg	Approx. 0.25 kg
Mounting	Snap-mounting on DIN rail EN 50022-35x15/7.5	Snap-mounting on DIN rail EN 50022-35x15/7.5

LOGO!Power 24 V

Overview



Application

LOGO!Power supplies are primary switched-mode power supplies that are optimized to the LOGO! logic modules in terms of functionality and design. With the wide input range of 85 V to 264 V AC, radio interference level B and assembly option in built-in miniature distribution boards, they can be used universally in a diverse range of applications in the low-end performance range.

Technical specifications

Power supply, type	24 V/1.3 A	24 V/2.5 A	24 V/4 A
Order No.	6EP1 331-1SH02	6EP1 332-1SH42	6EP1 332-1SH51
Input	Single-phase AC	Single-phase AC	Single-phase AC
Rated voltage $V_{in \text{ rated}}$	100 to 240 V AC	100 to 240 V AC	100 to 240 V AC
Voltage range	wide-range input 85 to 264 V AC	wide-range input 85 to 264 V AC	wide-range input 85 to 264 V AC
Overvoltage strength	$2.3 \times V_{in \text{ rated}}/1.3 \text{ ms}$	$2.3 \times V_{in \text{ rated}}/1.3 \text{ ms}$	$2.3 \times V_{in \text{ rated}}/1.3 \text{ ms}$
Mains buffering at $I_{out \text{ rated}}$	> 40 ms at $V_{in} = 187 \text{ V}$	> 40 ms at $V_{in} = 187 \text{ V}$	> 40 ms at $V_{in} = 187 \text{ V}$
Rated line frequency; range	50/60 Hz; 47 to 63 Hz	50/60 Hz; 47 to 63 Hz	50/60 Hz; 47 to 63 Hz
Rated current $I_{in \text{ rated}}$	0.7 to 0.35 A	1.22 to 0.66 A	1.95 to 0.97 A
Inrush current limitation (+25 °C)	< 15 A	< 30 A	< 30 A
I^2t	< 0.8 A ² s	< 3 A ² s	< 2.5 A ² s
Integrated line-side fuse	Internal	Internal	Internal
Recommended circuit-breaker (IEC 898) in mains supply line	From 16 A Characteristic B or from 10 A Characteristic C	From 16 A Characteristic B or from 10 A Characteristic C	From 16 A Characteristic B or from 10 A Characteristic C
Output	Stabilized, floating direct voltage	Stabilized, floating direct voltage	Stabilized, floating direct voltage
Rated voltage $V_{out \text{ rated}}$	24 V DC	24 V DC	24 V DC
Total tolerance, static	± 3 %	± 3 %	± 3 %
• Static mains compensation	Approx. 0.1 %	Approx. 0.1 %	Approx. 0.1 %
• Static load compensation	Approx. 1.5 %	Approx. 1.5 %	Approx. 1.5 %
Residual ripple (clock frequency approx. 90 kHz)	< 200 mV _{pp}	< 200 mV _{pp}	< 200 mV _{pp}
Spikes (bandwidth approx. 20 MHz)	< 300 mV _{pp}	< 300 mV _{pp}	< 300 mV _{pp}
Setting range	22.2 to 26.4 V	22.2 to 26.4 V	22.2 to 26.4 V
Status display	Green LED for output voltage OK	Green LED for output voltage OK	Green LED for output voltage OK
Power ON/OFF behavior	No overshoot of V_{out} (soft start)	No overshoot of V_{out} (soft start)	No overshoot of V_{out} (soft start)
Starting delay/voltage rise	< 0.5 s/typ. 15 ms	< 0.5 s/typ. 10 ms	< 0.5 s/typ. 35 ms
Rated current $I_{out \text{ rated}}$	1.3 A	2.5 A	4 A
Current range up to +55 °C	0 to 1.3 A	0 to 2.5 A	0 to 4 A
Parallel connection for increased output	Yes	Yes	Yes

Continued on page 13/9.

Power supply, type	24 V/1.3 A	24 V/2.5 A	24 V/4 A
Order No.	6EP1 331-1SH02	6EP1 332-1SH42	6EP1 332-1SH51
Efficiency			
Efficiency at $V_{out\ rated}$, $I_{out\ rated}$	typ. 82 %	typ. 87 %	typ. 89 %
Power loss at $V_{out\ rated}$, $I_{out\ rated}$	typ. 7 W	typ. 9 W	typ. 12 W
Control			
Dyn. mains compensation ($V_{in\ rated} \pm 15\%$)	< 0.2 % V_{out}	< 0.2 % V_{out}	< 0.2 % V_{out}
Dyn. load compensation (I_{out} : 10/90/10 %)	$\pm 1.5\%$ V_{out}	$\pm 1.5\%$ V_{out}	$\pm 1.5\%$ V_{out}
Settling time			
• Load step from 10 to 90 %	typ. 20 ms	typ. 20 ms	typ. 20 ms
• Load step from 90 to 10 %	typ. 20 ms	typ. 20 ms	typ. 20 ms
Protection and monitoring			
Current limitation	typ. 2 A	typ. 3.4 A	typ. 4.7 A
Short-circuit protection	Stabilized current characteristic	Stabilized current characteristic	Stabilized current characteristic
RMS sustained short-circuit current	< 4 A	< 8 A	< 10 A
Overload/short-circuit indicator	-	-	-
Safety			
Galvanic isolation primary/secondary	Yes, SELV output voltage V_{out} acc. to EN 60950 and EN 50178	Yes, SELV output voltage V_{out} acc. to EN 60950 and EN 50178	Yes, SELV output voltage V_{out} acc. to EN 60950 and EN 50178
Protective class	Class II (without PE conductor)	Class II (without PE conductor)	Class II (without PE conductor)
CE marking	Yes	Yes	Yes
UL/cUL (CSA) approval	Yes, cULus listed (UL 508, CSA 22.2), File E197259; cURus rec- ognized (UL 60950, CSA 22.2), File E151273	Yes, cULus listed (UL 508, CSA 22.2), File E197259; cURus rec- ognized (UL 60950, CSA 22.2), File E151273	Yes, cULus listed (UL 508, CSA 22.2), File E197259; cURus rec- ognized (UL 60950, CSA 22.2), File E151273
FM approval	Yes, Class I Div. 2, Group A, B, C, D T4	Yes, Class I Div. 2, Group A, B, C, D T4	Available soon
Appr. for use in marine vessels	Yes, GL, ABS	Yes, GL, ABS	Yes, ABS
Degree of protection (EN 60529)	IP20	IP20	IP20
EMC			
Interference emission	EN 55022 Class B	EN 55022 Class B	EN 55022 Class B
Line harmonics limitation	Not applicable	Not applicable	EN 61000-3-2
Interference immunity	EN 61000-6-2	EN 61000-6-2	EN 61000-6-2
Operating specifications			
Ambient temperature range	-20 to +55 °C with natural convection	-20 to +55 °C with natural convection	-20 to +55 °C with natural convection
Transportation and storage temperature range	-40 to +70 °C	-40 to +70 °C	-40 to +70 °C
Humidity rating	Climatic class 3K3 acc. to EN 60721, no condensation	Climatic class 3K3 acc. to EN 60721, no condensation	Climatic class 3K3 acc. to EN 60721, no condensation
Mechanical specifications			
Mains input connections L1, N	One screw-type terminal each for 0.5 to 2.5 mm ² single- core/finely stranded	One screw-type terminal each for 0.5 to 2.5 mm ² single- core/finely stranded	One screw-type terminal each for 0.5 to 2.5 mm ² single- core/finely stranded
Connections			
• Output +	2 screw-type terminals each for 0.5 to 2.5 mm ²	2 screw-type terminals each for 0.5 to 2.5 mm ²	2 screw-type terminals each for 0.5 to 2.5 mm ²
• Output -			
Dimensions (W x H x D) in mm	54 x 90 x 55	72 x 90 x 55	90 x 90 x 55
Weight	Approx. 0.17 kg	Approx. 0.25 kg	Approx. 0.34 kg
Mounting	Snap-mounting on DIN rail EN 50022-35x15/7.5	Snap-mounting on DIN rail EN 50022-35x15/7.5	Snap-mounting on DIN rail EN 50022-35x15/7.5



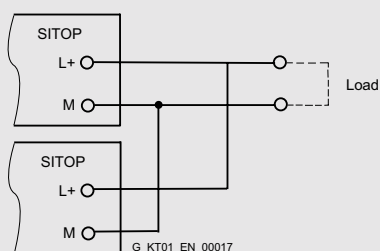

- 14/2 Power supplies general
- 14/2 Stabilized DC power supplies
- 14/5 Mains specifications, line-side connection
- 14/9 Possible system disturbances and causes
- 14/10 Mounting, mounting areas and fixing options
- 14/11 Planning aids
- 14/12 Parallel connection for redundant operation and performance enhancement
- 14/14 Series connection to increase the voltage
- 14/15 Battery charging
- 14/15 Fusing of the output circuit, selectivity



Power supplies general

Power supplies

In plant construction or mechanical engineering, or in any other situations in which electrical controls are used, a safe and reliable power supply is needed to supply the process with power.

The functional reliability of electronic controls and therefore the reliable operation of automated installations is extremely closely linked to the resistance of the load power supply to failure. Final control elements as well as input and output modules will only respond to command signals if the power supply is operating reliably.

In addition to general requirements such as reliability, particular demands are placed on the electromagnetic compatibility (EMC) of the power supply with reference to the tolerance range of the output voltage as well as its ripple.

Important factors that determine problem-free implementation are, in particular:

- An input current with a low harmonic content
- Low emitted interference and
- Adequate immunity (noise immunity) to interference

General notes on DC power supplies

The DC power supply is a static device with one or more inputs and one or more outputs that converts a system of AC voltage and AC current and/or DC voltage and DC current to a system with different values of DC voltage and DC current by means of

EMC	Types of interference
Emission (emitted interference)	Interference caused by television and radio reception Interference coupling with data lines or power supply cables
Immunity (immunity to interference)	Faults on the power cable due to switching non-resistive loads such as motors or contactors Static discharge due to lightning strikes Electrostatic discharge through the human body Conducted noise induced by radio frequencies

Certain disturbing phenomena

electromagnetic induction for the purpose of transmitting electrical energy.

The type of construction of a DC power supply is usually decided by its intended use.

Unstabilized DC power supplies

The AC mains voltage is transformed using 50 Hz/60 Hz safety transformers to a protective extra-low voltage and smoothed with down-circuit rectification and capacitor filtering.

In the case of unstabilized DC power supplies, the DC output voltage is not stabilized at a specific value, but the value is varied in accordance with the variation in (mains) input voltage and the loading.

The ripple is in the Volt range and is dependent on the loading. The value for the ripple is usually specified as a percentage of the DC output voltage level. Unstabilized DC power supplies are characterized by their rugged, uncomplicated design that is limited to the important factors and focussed on a long service life.

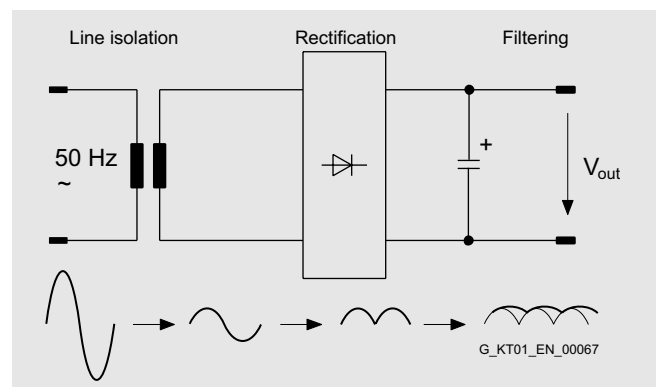

Block diagram of an unstabilized power supply

Stabilized DC power supplies

Stabilized DC power supplies have electronic regulation circuits that maintain the DC voltage at the output at a specific value with as little variation as possible. Effects such as variation in input voltage or changes in load at the output are electrically compensated in the specified function area.

The ripple in the output voltage for stabilized DC power supplies lies in the millivolt range and is mainly dependent on the loading at the outputs.

Stabilized DC power supplies can be implemented on different functional principles. The most common types of circuit are:

- Linear stabilized power supplies
- Magnetic voltage stabilizer
- Secondary pulsed switched-mode power supplies
- Primary pulsed switched-mode power supplies

The most suitable principle for a particular application case will depend mainly on the application. The objective is to generate a DC voltage to supply the specific load as inexpensively and as accurately as possible.

Stabilized DC power supplies (continued)

Linear stabilized power supplies

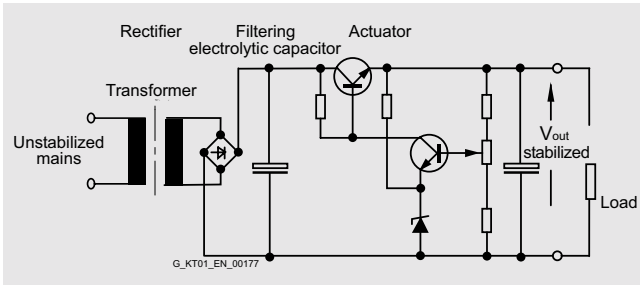

Block diagram: Linear regulator

The linear regulator operates according to a conventional principle. The supply is provided from an AC supply system (one, two or three conductor supply).

A transformer is used to adapt it to form the required secondary voltage.

The rectified and filtered secondary voltage is converted into a stabilized voltage at the output by a regulation section. The regulation section comprises a final control element and a control amplifier. The difference between the stabilized output voltage and the unstabilized voltage at the filter capacitor is converted into a thermal loss in the final control element. The final control element functions in this case like a rapidly changeable ohmic impedance. The thermal loss that arises in each case is the product of output current and voltage drop over the final control element.

This system is extremely adaptable. Even without any further modifications, several output voltages are possible. In the case of multiple outputs, the individual secondary circuits are generated from separate secondary windings of the input transformer. Some applications can only be resolved in accordance with this circuit principle. Especially when highly accurate regulation, minimal residual ripple and fast compensation times are required.

The efficiency is, however, poor and the weight and volume are considerable. The linear regulator is therefore only an economical alternative at low power ratings.

Advantages:

- Simple, well-proven circuit principle
- Good to excellent control characteristics
- Fast settling time

Disadvantages:

- Relatively high weight and large volume due to the 50 Hz transformer
- Poor efficiency, heat dissipation problems
- Low storage time

Magnetic stabilizer

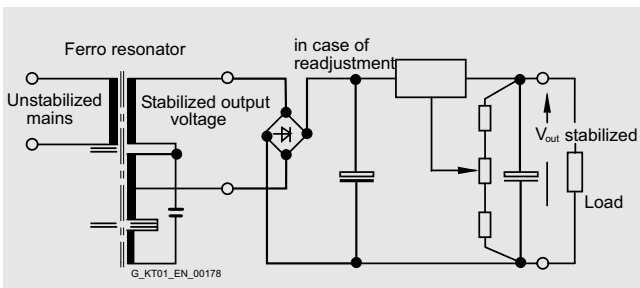

Block diagram: Magnetic stabilizer

The complete transformer comprises two components. The so-called "ferro resonator" and a series connected auxiliary regulation section. The input winding and the resonance winding of the magnetic stabilizer are decoupled to a large extent by means of the air gap. The magnetic stabilizer supplies a well-stabilized AC voltage. This is rectified and filtered. The transformer itself is operated in the saturation range.

The ferro resonator frequently has a linear regulator connected to the output to improve the control accuracy. Secondary pulsed switched-mode regulators are frequently also connected to the output.

The magnetic stabilizer technique is reliable and rugged but is also large-volume, heavy and relatively expensive.

Advantages:

- Good to excellent control characteristics in combination with series connected linear regulators
- Significantly better efficiency than a linear regulator alone

Disadvantages:

- The ferro resonator is frequency dependent
- The power supplies are large and heavy due to the magnetic components

Secondary pulsed switched-mode power supplies:

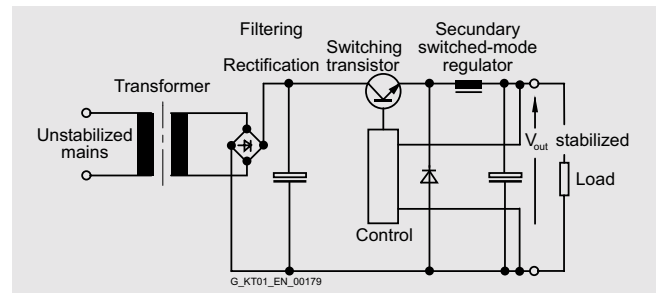

Block diagram: Secondary pulsed switched-mode power supply

Isolation from the supply system is implemented in this case with a 50 Hz transformer. Following rectification and filtering, the energy is switched at the output by means of pulsing through a switching transistor in the filtering and storage circuit. Thanks to the transformer at the input, that acts as an excellent filter, the mains pollution is low. The efficiency of this circuit is extremely high.

This concept offers many advantages for power supplies with numerous different output voltages.

To protect the connected loads, however, care must be taken; in the event of the switching transistor breaking down, the full, unstabilized DC voltage of the filter capacitor will be applied to the output. This danger, however, also exists in the case of linear stabilized power supplies.

Advantages:

- Simple design and high efficiency
- Multiple outputs, also galvanically isolated from one another, are easily implemented by means of several secondary windings
- Fewer problems with interference than with primary pulsed switched-mode power supplies

Disadvantages:

- The 50 Hz transformer makes the power supplies relatively large and heavy
- The output ripple (spikes) correspond to those of a primary pulsed switched-mode power supply

Stabilized DC power supplies

Stabilized DC power supplies (continued)

Primary pulsed switched-mode power supplies:

In other literature, the term SMPS (Switch Mode Power Supply) or primary switched-mode regulator is often used.

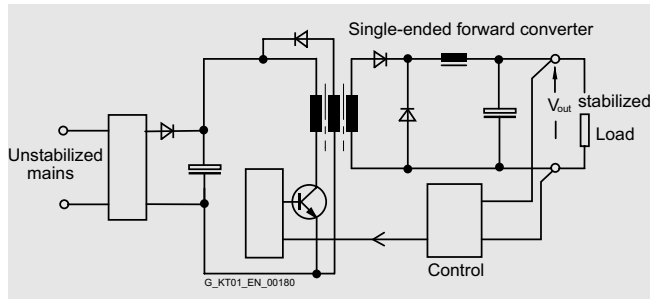

Block diagram: Single-ended forward converter

The primary switched-mode regulators are available in many different circuit variants. The most important basic circuits are single-ended forward converters, flyback converters, half-bridge converters, full-bridge converters, push-pull converters and resonance converters.

The general principle of operation of the primary switched-mode regulator is shown in the block diagram of the single-ended forward converters.

The unstabilized supply voltage is first rectified and filtered. The capacitance of the capacitor in the DC link determines the storage time of the power supply on failure of the input voltage. The voltage at the DC link is approximately 320 V DC for a 230 V supply. A single-ended converter is then supplied with this DC voltage and transfers the primary energy through a transformer to the secondary side with the help of a pulse width regulator at a high switching frequency. The switching transistor has low power losses when functioning as a switch, so that the power balance lies between > 70 % and 90 % depending on the output voltage and current.

The volume of the transformer is small in comparison with a 50 Hz transformer due to the high switching frequency because the transformer size taking into account the higher switching frequency is smaller. Using modern semiconductors, switching frequencies of 100 kHz and above can be achieved. At excessively high switching frequencies, the switching losses increase, so that in each case a compromise has to be made between a high efficiency and the largest possible switching frequency. In most applications, the switching frequencies lie between 20 kHz and 250 kHz depending on the output power.

The voltage from the secondary winding is rectified and filtered. The system deviation at the output is fed back to the primary circuit through an optocoupler. By controlling the pulse width (conducting phase of the switching transistor in the primary circuit), the necessary energy is transferred to the secondary circuit and the output voltage is regulated. During the non-conducting phase of the switching transistor, the transformer is demagnetized through an auxiliary winding. Just enough energy is transferred as is removed at the output.

The maximum pulse width for the pulse/pause ratio for these circuits is < 50 %.

Advantages:

- Small magnetic components (transformer, storage reactor, filter) thanks to the high operating frequency
- High efficiency thanks to pulse width regulation
- Compact equipment units
- Forced-air cooling is not necessary up to the kW range
- High storage times are possible on mains failure by increasing the capacitance in the DC link
- Larger input voltage range is possible

Disadvantages:

- High cost circuit, many active components
- Higher costs for interference suppression
- The mechanical design must be in accordance with HF criteria

Primary switched-mode power supplies have become more and more popular over the last few years. Especially due to the small size, low weight, high efficiency and excellent price/performance ratio.

Summary

The most important characteristics of the circuit types described above are summarized in Table 2.

Comparison criteria	Circuit types			
	Primary switched-mode	Secondary switched-mode	Linear regulator	Magnetic stabilizer
Input voltage range	Very large	Medium	Very small	Large
Regulation speed	Medium	Medium	Very fast	Slow
Storage time after power failure	Very long	Long	Very short	Long
Residual ripple	Medium	Medium	Very low	Medium
Power loss	Very small	Small	Large	Very small
Frame size	Very small	Medium	Very large	Large
Weight	Very light	Medium	Heavy	Very heavy
Interference suppression costs	Very large	Medium	Low	Medium

Comparison criteria for basic circuit variants

Supply system data

When dimensioning and selecting plant components, the mains data, mains conditions and the operating modes must be taken into account for these components.

The most important data for a supply system is the rated voltage and rated frequency. These data for the supply system are designated as rated values in accordance with international agreements.

Rated voltage and rated frequency

Since May 1987, the standard DIN IEC 60038 "IEC rated voltages" has been applicable in the Federal Republic of Germany.

The international standard IEC 60038, Edition 6, 1983, "IEC standard voltages" has been included in this standard unmodified.

The IEC 60038 standard is the result of an international agreement to reduce the diverse rated voltage values that are in use for electrical supply networks and traction power supplies, load installations and equipment.

Conversion of low-voltage supply systems

In the low-voltage range, it is emphasized in IEC 60038 that 220/380 V and 240/415 V voltage values for three-phase electricity supplies have been replaced by a single internationally standardized value of 230/400 V.

The tolerances for the rated voltages of the supply systems that were specified for the transition period up to 2003 were intended to ensure that equipment rated for the previous voltages could be operated safely until the end of its service life.

Year	Rated voltage	Tolerance range
Up to 1987	220 V/380 V	-10 % to +10 %
From 1988 to 2003	230 V/400 V	-10 % to + 6 %
From 2003	230 V/400 V	-10 % to +10 %

Conversion of low-voltage supply systems

The IEC recommendations have been implemented as national regulations in the most important countries, as far as the conditions in the country allow.

International supply voltages and frequencies in low-voltage supply systems

Country	Mains voltage
Western Europe:	
Belgium	50 Hz 230/400 – 127-220 V
Denmark	50 Hz 230/400 V
Germany	50 Hz 230/400 V
Finland	50 Hz 230/400-500 ¹⁾ – 660 ¹⁾ V
France	50 Hz 127/220 – 230/400 – 500 ¹⁾ – 380/660 ¹⁾ – 525/910 ¹⁾ V
Greece	50 Hz 230/400 – 127/220 ²⁾ V
Great Britain	50 Hz (230/400 V) ³⁾
Ireland	50 Hz 230/400 V
Iceland	50 Hz 127/220 ²⁾ – 230/400 V
Italy	50 Hz 127/220 – 230/400 V
Luxembourg	50 Hz 230/400 V
Netherlands	50 Hz 230/400 – 660 ¹⁾ V
Northern Ireland	50 Hz 230/400 – Belfast 220/380 V
Norway	50 Hz 230-230/400-500 ¹⁾ – 690 ¹⁾ V
Austria	50 Hz 230/400 – 500 ¹⁾ – 690 ¹⁾ V
Portugal	50 Hz 230/400 V
Sweden	50 Hz 230/400 V
Switzerland	50 Hz 230/400 – 500 ²⁾ V
Spain	50 Hz 230/400 V
Eastern Europe:	
Albania	50 Hz 230/400 V
Bulgaria	50 Hz 230/400 V
Russian Federation	50 Hz 230/400 – 690 ¹⁾ V
Croatia	50 Hz 230/400 V
Poland	50 Hz 230/400 V
Rumania	50 Hz 230/400 V
Serbia	50 Hz 230/400 V
Slovakia	50 Hz 230/400 – 500 ¹⁾ – 690 ¹⁾ V
Slovenia	50 Hz 230/400 V
Chechnya	50 Hz 230/400 – 500 ¹⁾ – 690 ¹⁾ V
Hungary	50 Hz 230/400 V

1) Industry only.

2) No further expansion.

3) From 2003.

Technical information and configuration

Mains specifications, line-side connection

International supply voltages and frequencies in low-voltage supply systems (continued)

Country	Mains voltage
Middle-East:	
Afghanistan	50 Hz 220/380 V
Bahrain	50 Hz 230/400 V
Cyprus	50 Hz 240/415 V
Iraq	50 Hz 220/380 V
Israel	50 Hz 230/400 V
Jordan	50 Hz 220/380 V
Kuwait	50 Hz 240/415 V
Lebanon	50 Hz 110/190 – 220/380 V
Oman	50 Hz 220/380 – 240/415 V
Qatar	50 Hz 240/415 V
Saudi Arabia	60 Hz 127/220 – 220/380 – 480 ¹⁾ V (220/380 – 240/415 V 50 Hz: remainder only)
Syria	50 Hz 115/200 – 220/380 – 400 ¹⁾ V
Turkey	50 Hz 220/380 V (parts of Istanbul: 110/190 V)
United Arab Emirates (Abu Dhabi; Ajman; Dubai; Fujayrah; Ras al Khaymah; Sharjah; Um al Qaywayn)	50 Hz 220/380 – 240/415 V
Yemen (North)	50 Hz 220/380 V
Yemen (South)	50 Hz 230/400 V
Far East:	
Bangladesh	50 Hz 230/400 V
Burma	50 Hz 230/400 V
Peoples Republic of China	50 Hz 127/220 – 220/380 V (in mining: 1140 V)
Hong Kong	50 Hz 200/346 V
India	50 Hz 220/380 – 230/400 – 240/415 V
Indonesia	50 Hz 127/220 – 220/380 – 400 ¹⁾ V
Japan	50 Hz 100/200 – 400 ¹⁾ V
South Honshu, Shikoku, Kyushu, Hokkaido, North Honshu	60 Hz 110/220 – 440 ¹⁾ V
Cambodia	50 Hz 120/208 V – Phnom Penh 220/238 V
Korea (North)	60 Hz 220/380 V
Korea (South)	60 Hz 100/200 ²⁾ – 220/380 – 440 ¹⁾ V
Malaysia	50 Hz 240/415 V
Peoples Republic of Mongolia	50 Hz 220/380 V
Pakistan	50 Hz 230/400 V
Philippines	60 Hz 110/220 – 440 V
Singapore	50 Hz 240/415 V
Sri Lanka	50 Hz 230/400 V
Taiwan	60 Hz 110/220 – 220 – 440 V
Thailand	50 Hz 220/380 V
Vietnam	50 Hz 220/380 V
North America:	
Canada	60 Hz 600 – 120/240 – 460 – 575 V
USA	60 Hz 120/208 – 120/240 – 277/480 – 600 ¹⁾ V
Central America:	
Bahamas	60 Hz 115/200 – 120/208 V
Barbados	50 Hz 110/190 – 120/208 V
Belize	60 Hz 110/220 – 220/440 V
Costa Rica	60 Hz 120/208 ²⁾ – 120/240 – 127/220 – 254/440 ²⁾ – 227/480 ¹⁾ V
Dominican Republic	60 Hz 120/208 – 120/240 – 480 ¹⁾ V

1) Industry only.

2) No further expansion.

International supply voltages and frequencies in low-voltage supply systems (continued)

Country	Mains voltage
Central America (continued):	
Guatemala	60 Hz 120/208 – 120/240 – 127/220 – 277/480 ¹⁾ – 480 ¹⁾ – 550 ¹⁾ V
Haiti	50 Hz 220/380 V (Jacmel), 60 Hz 110/220 V
Honduras	60 Hz 110/220 – 127/220 – 277/480 V
Jamaica	50 Hz 110/220 – 440 ¹⁾ V
Cuba	60 Hz 120/240 – 220/380 – 277/480 ¹⁾ – 440 ¹⁾ V
Mexico	60 Hz 127/220 – 440 ¹⁾ V
Nicaragua	60 Hz 110/220 – 120/240 – 127/220 – 220/440 – 254/40 ¹⁾ V
Panama	60 Hz 120/208 ¹⁾ – 120/240 – 254/440 ¹⁾ – 277/480 ¹⁾ V
Puerto Rico	60 Hz 120/208 – 480 V
El Salvador	60 Hz 110/220 – 120/208 – 127/220 – 220/440 – 240/480 ¹⁾ – 254/440 ¹⁾ V
Trinidad	60 Hz 110/220 – 120/240 – 230/400 V
South America:	
Argentina	50 Hz 220/380 V
Bolivia	60 Hz 220/380 – 480 V, 50 Hz 110/220 – 220/380 V (exception)
Brazil	60 Hz 110/220 – 220/440 – 127/220 – 220/380 V
Chile	50 Hz 220/380 V
Ecuador	60 Hz 120/208 – 127/220 V
Guyana	50 Hz 110/220 V (Georgetown), 60 Hz 110/220 – 240/480 V
Columbia	60 Hz 110/220 – 150/260 – 440 V
Paraguay	60 Hz 220/380 – 220/440 V
Peru	60 Hz 220 – 220/380/440 V
Surinam	60 Hz 115/230 – 127/220 V
Uruguay	50 Hz 220 V
Venezuela	60 Hz 120/208 – 120/240 – 208/416 – 240/480 V
Africa:	
Egypt	50 Hz 110/220 – 220/380 V
Ethiopia	50 Hz 220/380 V
Algeria	50 Hz 127/220 – 220/380 V
Angola	50 Hz 220/380 V
Benin	50 Hz 220/380 V
Ivory Coast	50 Hz 220/380 V
Gabon	50 Hz 220/380 V
Ghana	50 Hz 127/220 – 220/380 V
Guinea	50 Hz 220/380 V
Kenya	50 Hz 220/380 V
Cameroon	50 Hz 127/220 – 220/380 V
Congo	50 Hz 220/380 V
Liberia	60 Hz 120/208 – 120/240 V
Libya	50 Hz 127/220 ²⁾ – 220/380 V
Madagascar	50 Hz 127/220 – 220/380 V
Malawi	50 Hz 220/380 V
Mali	50 Hz 220/380 V
Morocco	50 Hz 115/200 – 127/220 – 220/380 – 500 ¹⁾ V
Mauritius	50 Hz 240/415 V
Mozambique	50 Hz 220/380 V
Namibia	50 Hz 220/380 V
Niger	50 Hz 220/380 V

1) Industry only.

2) No further expansion.

Mains specifications, line-side connection

International supply voltages and frequencies in low-voltage supply systems (continued)

Country	Mains voltage
Africa (continued):	
Nigeria	50 Hz 220/415 V
Rwanda	50 Hz 220/380 V
Zambia	50 Hz 220/380 V – 415 – 550 ¹⁾ V
Senegal	50 Hz 127/220 – 220/380 V
Sierra Leone	50 Hz 220/380 V
Somalia	50 Hz 220-220/440 V
Sudan	50 Hz 240/415 V
South Africa	50 Hz 220/380 – 500 ¹⁾ – 550/950 ¹⁾ V
Swaziland	50 Hz 220/380 V
Tanzania	50 Hz 230/400 V
Togo	50 Hz 127/220 – 220/380 V
Tunisia	50 Hz 115/200 – 220/380 V
Uganda	50 Hz 240/415 V
Zaire	50 Hz 220/380 V
Zimbabwe	50 Hz 220/380 V

Connection and fusing on the line side

All SITOP and LOGO!Power supplies are built-in devices. For installation of the devices, the relevant DIN/VDE specifications or country-specific regulations must be taken into account. The supply voltage must be connected in accordance with VDE 0100 and VDE 0160. On installation, protective gear and isolating gear must be provided for disconnecting the power supply.

Power supply units cause a current inrush immediately after application of the input voltage due to charging of the load capacitor; it soon falls back to the rated input current level after a few milliseconds. Aside from the internal impedances of the power supply, the current inrush is largely dependent on the size of the input voltage applied as well as the source impedance of the supply network and the line impedance of the supply line. The maximum current inrush for SITOP power supplies is specified in the applicable technical data. It is important for dimensioning up-circuit protective devices.

Single-phase SITOP and LOGO!Power supplies are equipped with internal device protection (fuses). For connection to the

supply system, only one protective device (fuse or circuit-breaker) must be provided for conductor protection in accordance with the current rating of the installed cable. The circuit-breakers recommended in the data sheets and operating instructions have been selected such that even during the maximum current inrush that can occur under worst case conditions on switching on the supply voltage, the circuit-breaker will not trip.

Three-phase SITOP power supplies do not have internal device protection. The up-circuit protective device (three-phase coupled miniature circuit-breaker or motor protection switch) protects the cables and devices. The protective devices specified in the data sheets and operating instructions are optimized to the characteristics of the relevant power supplies.

Overview

The quality of the mains voltage has become a decisive factor in the functioning, reliability, maintenance costs and service life of highly sensitive electronic installations and devices (computers, industrial controls, instrumentation, etc.).

Mains disturbances cause system failures and affect the function of plants as well as electronic consumers. They can also result in total failure of the installation or equipment.

The most frequent types of disturbance are:

- Long-term overvoltages
- Long-term undervoltages
- Burst interference and transients
- Voltage reduction and surges
- Electrical noise
- Momentary mains breaks
- Long-term mains breaks

Disturbances in mains voltages can occur individually or in combination. Possible reasons for these disturbances and reactions can be:

Mains disturbances can be caused by a number of things, e.g.:

- Switching operations in the supply system
- Long cable paths in the supply system
- Environmental influences, such as storms
- Mains overloads

Typical causes of mains disturbances generated in-house are:

- Thyristor-controlled drives
- Lifts, air-conditioning, photocopiers
- Motors, power factor correction equipment
- Electrical welding, large machines
- Switching of lighting equipment

Mains disturbances	Percentage of total disturbance	Effect
Overvoltage Over a long period, the mains voltage is exceeded by more than +6% (acc. to DIN IEC 60038)	approx. 15% - 20%	Can result in overheating and even thermal destruction of individual components. Causes total failure.
Undervoltage Over a long period, the mains voltage is reduced by more than 10% (acc. to DIN IEC 60038)	approx. 20% - 30%	Can result in undefined operating states for loads. Causes data errors.
Burst interference Energy-rich impulses (e.g. 700 V/1 ms) and energy-poor transients (e.g. 2500 V/20 μs) result from switching operations in the supply system	approx. 30% - 35%	Can result in undefined operating states for the loads and can lead to the destruction of components.
Voltage reduction and surges The voltage level changes suddenly and in an uncontrolled manner, e.g. due to changes in loading and long cable runs	approx. 15% - 30%	Can result in undefined operating states and destruction of components. Causes data errors.
Electrical noise A mix of frequencies superimposed on the mains due to bad grounding and/or strong HF emitters, such as television transmitters or storms	approx. 20% - 35%	Can result in undefined operating states for loads. Causes data errors.
Voltage interruption Short-term interruption of the mains voltage (up to 10 ms), due to short-circuiting in neighboring supply systems or starting of large electrical machines	approx. 8% - 10%	Can result in undefined operating states for loads especially those with insufficient mains buffering. Causes data errors.
Voltage interruption Long interruption of the mains voltage (longer than 10 ms)	approx. 2% - 5%	Can result in undefined operating states for loads especially those with insufficient mains buffering. Causes data errors.

Mains disturbances and effects

The SITOP product family offers a range of possibilities for minimizing or preventing the risk of mains disturbances at the planning stage.

Technical information and configuration

Mounting, Mounting areas and fixing options

Mounting

All SITOP and LOGO!Power supplies are built-in devices. With the exception of the variants with IP65 degree of protection, the power supplies must be mounted vertically so that the air can enter the ventilation slots at the bottom of the devices and leave through the upper part of the devices. If the units are not mounted vertically (at your own risk), the ambient temperature

should not exceed +45 °C and the load current should not exceed approx. 50% of the rated current value. Variants with IP65 degree of protection can be mounted in any mounting position. The minimum distances specified in the corresponding operating manual for the top, bottom, and side of the devices must be observed to ensure free air convection.

Mounting areas and fixing options

Power supply	Order No.	Required mounting area in mm (W x H)	Mounting on a standard rail acc. to DIN EN 50022		Wall mounting
			35 x 7.5 mm	35 x 15 mm	
SITOP power 24 V, one-phase and two-phase power supplies					
24 V/0.5 A	6EP1331-2BA10	22.5 x 180	X	X	
24 V/0.375 A	6EP1731-2BA00	22.5 x 180	X	X	
24 V/2 A	6EP1331-2BA00	50 x 225	X	X	
	6ES7307-1BA00-0AA0	50 x 205		1)	
	6ES7305-1BA80-0AA0	80 x 225		1)	
	6EP1732-0AA00	80 x 235		X	X
24 V/2.5 A	6EP1332-1SH12	80 x 335		X	X
24 V/3.5 A	6EP1332-1SH31	160 x 280	X	X	X
24 V/4 A	6EP1332-1SH22	80 x 335		X	X
24 V/5 A	6EP1333-3BA00	70 x 225	X	X	
	6EP1333-2BA00	75 x 225	X	X	
	6EP1333-2AA00	75 x 225	X	X	
	6ES7307-1EA00-0AA0	80 x 205		1)	
	6ES7307-1EA80-0AA0	80 x 225		1)	
	6EP1333-1AL12	160 x 230	X	X	
24 V/10 A	6EP1334-3BA00	90 x 225	X	X	
	6EP1334-2BA00	100 x 225	X	X	
	6EP1334-2AA00	100 x 225	X	X	
	6EP1334-2CA00	160 x 290			X
	6ES7307-1KA01-0AA0	120 x 205		1)	
	6EP1334-1AL12	160 x 230	X	X	
	6EP1334-1SH01	200 x 325		X	
24 V/20 A	6EP1336-3BA00	160 x 225	X	X	
	6EP1336-2BA00	320 x 225	X	X	
	6EP1536-2AA00	320 x 280	X	X	
24 V/40 A	6EP1337-3BA00	240 x 225	X	X	
SITOP power 24 V, three-phase power supplies					
24 V/10 A	6EP1434-2BA00	320 x 225	X	X	
24 V/20 A	6EP1436-3BA00	160 x 225	X	X	
	6EP1436-2BA00	320 x 225	X	X	
24 V/30 A	6EP1437-2BA00	320 x 280	X	X	
24 V/40 A	6EP1437-3BA00	240 x 225	X	X	
	6EP1437-2BA10	320 x 280	X	X	
SITOP power 24 V, uninterruptible power supplies					
DC UPS 6 A (with serial interface / USB interface)	6EP1931-2DC21 (-2DC31/-2DC41)	50 x 225	X	X	
DC UPS 15 A (with serial interface / USB interface)	6EP1931-2EC21 (-2EC31/-2EC41)	50 x 225	X	X	
DC UPS 40 A	6EP1931-2FC01	280 x 290	X	X	

Power supply	Order No.	Required mounting area in mm (W x H)	Mounting on a standard rail acc. to DIN EN 50022		Wall mounting
			35 x 7.5 mm	35 x 15 mm	
SITOP power 24 V, uninterruptible power supplies					
Battery module 2.5 Ah	6EP1935-6MD31	285 x 171	X	X	X
Battery module 3.2 Ah	6EP1935-6MD11	210 x 171	X	X	X
Battery module 7 Ah	6EP1935-6ME21	206 x 188			X
Battery module 12 Ah	6EP1935-6MF01	273 x 138			X
SITOP power 24 V, additional components					
Buffer module	6EP1961-3BA00	70 x 225	X	X	
Redundancy module	6EP1961-3BA20	70 x 225	X	X	
Diagnosis module	6EP1961-2BA00	72 x 190	X	X	
SITOP power alternative voltages					
3-52 V/120 W	6EP1353-2BA00	75 x 225	X	X	
2 x 15 V/3.5 A	6EP1353-0AA00	75 x 325	X	X	
48 V/20 A	6EP1457-3BA00	240 x 255	X	X	
SITOP power AS interface					
30 V/2.4 A	6EP1632-1AL01	260 x 80			X
30 V/7 A	6EP1354-1AL01	200 x 325		X	
LOGO!Power supplies					
5 V/3 A	6EP1311-1SH02	54 x 130	X	X	
12 V/1.9 A	6EP1321-1SH02	54 x 130	X	X	
15 V/1.9 A	6EP1351-1SH02	54 x 130	X	X	
24 V/1.3 A	6EP1331-1SH02	54 x 130	X	X	
5 V/6.3 A	6EP1311-1SH12	72 x 130	X	X	
12 V/4.5 A	6EP1322-1SH02	72 x 130	X	X	
15 V/4 A	6EP1352-1SH02	72 x 130	X	X	
24 V/2.5 A	6EP1332-1SH42	72 x 130	X	X	
24 V/4 A	6EP1332-1SH51	90 x 130	X	X	

1) With an additional mounting adapter.

Planning aids

For planning and construction, operating manuals with mounting options, dimension drawings, and principle circuits with pin names in different file formats (suitable for CAD applications) are available for download on the Internet.

Additional information is available in the Internet under:



<http://www.siemens.com/automation/sitop>

Parallel connection for redundant operation and performance enhancement

Parallel connection for redundant operation

Two SITOP power supplies of the same type can be connected in parallel through diodes for a redundant configuration. Hundred percent redundancy only exists for two power supplies when the total load current is no higher than that which one power supply can supply alone and when the supply for the primary side is also implemented redundantly (i.e. a short-circuit on the primary side will not trigger a shared fuse which would disconnect both power supplies from the mains).

Parallel connection with decoupling diodes for redundant operation is permitted for all SITOP power supplies. The diodes V1 and V2 are used for decoupling. They must have a blocking voltage of at least 40 V and it must be possible to load them with a current equal to or greater than the maximum output current of the respective SITOP power supply. For diode dimensioning, see the following note "General information on selection of diodes".

As a simple alternative to diode dimensioning, the prepared add-on module "SITOP modular redundancy module" (Order No. 6EP1961-3BA20, see Section 8) is available for redundant connection of two power supplies.

General information on selection of diodes:

The diodes must be dimensioned for the maximum dynamic current. This can be the dynamic current during power-up in the short-circuit case or the dynamic current during a short-circuit in operation (the largest of the two values should be taken from the relevant technical specifications).

To dissipate the significant power losses of the decoupling diodes (current x diode conductive-state voltage), the diodes must be mounted on suitably dimensioned heat sinks.

An additional safety margin is recommended, because the output capacitor integral to the power supply generates an additional peak current in the short-circuit case. This additional current flows only for a few milliseconds which is a period (< 8.3 ms, so-called permissible surge current for diodes) in which diodes are permitted to be loaded with a multiple of the rated current.

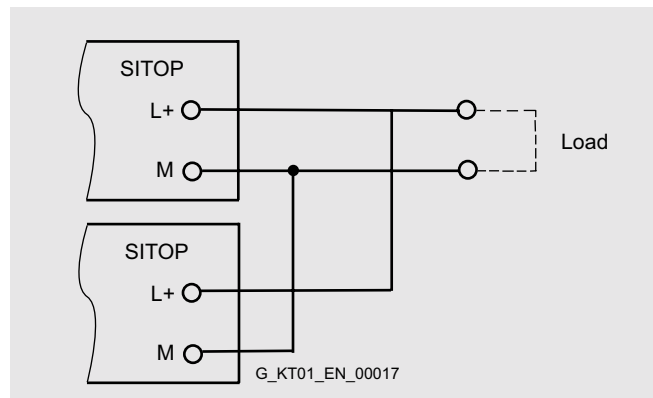

Parallel connection of two SITOP power supplies for redundant operation

Example 1

Two single-phase SITOP modular power supplies with 10 A rated output current (Order No.: 6EP1334-3BA00) are connected in parallel. The dynamic current in the event of a short-circuit during operation is approx. 30 A for 25 ms.

The diodes should therefore have a loading capability of 40 A to be safe, the common heat sink for both diodes must be dimensioned for the maximum possible current of approx. 24 A (RMS sustained short-circuit current) x diode conductive-state voltage.

Example 2

Two SITOP power supplies with 40 A rated output current (Order No. 6EP1437-2BA10) are connected in parallel. The dynamic current in the event of a short-circuit during operation is approx. 70 A for 600 ms, the RMS value is < 54 A.

The selected diodes should therefore have a loading capability of 100 A to be safe, the heat sink per diode must be dimensioned for the continuous possible current of 54 A x diode conductive-state voltage.

Parallel connection for performance enhancement

To enhance performance, identical types of most SITOP power supplies can be connected in parallel galvanically (the same principle as parallel connection for redundant operation, but without decoupling diodes):

Advantage

The costs for mounting the diodes onto heat sinks and the not insignificant power losses of the decoupling diodes (current x diode conducting-state voltage) are avoided.

The types permitted for direct galvanic parallel connection are listed in the relevant technical specifications under "Output, parallel connection for performance enhancement".

Precondition

- The output cables connected to terminals L+ and M of every SITOP power supply should be installed with an identical length and cross-section (or the same impedance) to the common external linking point.

- The SITOP power supplies connected in parallel must be switched simultaneously using a common switch in the mains supply line (e.g. using the main switch available in control cabinets).
- The output voltages of the power supplies must be measured under no-load operation before they are connected in parallel and are permitted to differ by up to 50 mV. This usually corresponds to the factory default setting. If the output voltage is changed in the case of variable power supplies, the M terminals should first be connected and then the voltage difference between the L+ output terminals measured under no-load conditions before these are connected. This voltage difference must not exceed 50 mV.

Note

With a direct galvanic connection in parallel of more than two SITOP power supplies, further circuit measures may be necessary for short-circuit and overload protection!

Parallel connection for redundant operation and for performance enhancement

Almost 100% redundancy

Using the types permitted for direct galvanic parallel connection (see the relevant technical specifications under "Output, parallel connection for performance enhancement"), the performance can be increased without the need for decoupling diodes and redundancy of almost 100% can be implemented by direct galvanic parallel connection of an additional power supply of the same type to the power supplies required to satisfy the performance requirements. This means that at least one more power supply is required than is necessary for the sum of all load currents.

A decoupling diode is normally required for redundancy to ensure that a power supply that has failed as a result of short-circuiting of the outputs (especially as a result of short-circuiting the output electrolytic capacitor) does not also short-circuit the power supply that remains intact. A redundancy of almost 100% can be implemented with this type of circuit.

Example

A load current of up to 40 A is required, the power supply must operate on both 400 V and 500 V three-phase supplies (without switch-over).

The three-phase 20 A SITOP modular power supply (Order No.: 6EP1436-3BA00) is suitable for this purpose. For load currents up to 40 A, direct galvanic parallel connection of two SITOP modular power 20 supplies is necessary. By connecting another SITOP modular 20 in parallel, performance enhancement and redundancy are implemented simultaneously (if one of the three power supplies fails to supply an output voltage, the remaining two 20 A power supplies are capable of supplying a total load current of 40 A).

Note

With a direct galvanic connection in parallel of more than two SITOP power supplies, further circuit measures may be necessary for short-circuit and overload protection!

Series connection to increase the voltage

Series connection to increase the voltage

To generate a load voltage of e.g. 48 V DC, two 24 V SITOP power supplies of the same type can be connected in series. The SITOP outputs L+ and M are isolated up to at least 60 V DC against PE (air gaps and creepage distances as well as radio interference suppression capacitors on L+ and M against PE), so that with this type of series connection (see Figure), the following points can be earthed:

- M of the lower power supply (results in +48 V DC against PE)
- Midway M/L+ between both power supplies (results in ± 24 V DC against PE)
- L+ of the upper power supply (results in -48 V DC against PE)

Note:

If two devices are connected in parallel, it cannot be guaranteed that the voltage will remain below maximum permissible SELV voltage of 60 V DC in the event of a fault.

The purpose of diodes V1 and V2 is to protect the electrolytic output capacitor integrated in the power supply against reverse voltages > 1 V. As a result of the not absolutely simultaneous power-up (even when a common mains switch is used for switching on, differences of a few tens of milliseconds can occur between the various start-up delays), the SITOP power which starts up more quickly supplies current from output L+ to the M output of the slower SITOP power whose output electrolytic capacitor is then theoretically impermissibly discharged.

The internal LC filter causes the internal rectifier diode on the secondary side to accept this current a few milliseconds later; this means that the external diode connected with its anode to M and cathode to L+ is essential on each power supply. These diodes are, however, only loaded dynamically, so the 8.3 ms surge current loading capability (specified in the data sheets for suitable diodes) can be used as a basis for dimensioning and it is not usually necessary to cool the diodes using heat sinks.

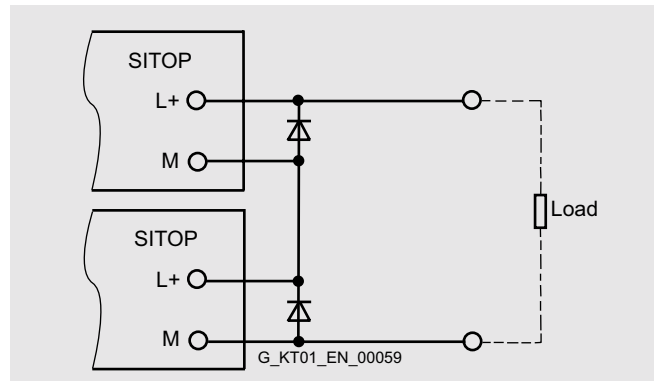

Series connection: Two SITOP power supplies for doubling the voltage

Example:

Two single-phase SITOP power supplies with 10 A rated output current (Order No.: 6EP1334-2BA00) should be connected in series to increase the voltage. They supply approximately 38 A dynamically for 200 ms on power-up in the short-circuit case or e.g. also with loads with a high-capacitance input capacitor that momentarily act as a short-circuit at the start.

Suitable diodes for V1 and V2 are, for example, of Type SB 340 ¹⁾ (Schottky diode in axially wired enclosure DO-201AD with approx. 5.3 mm diameter and approx. 9.5 mm length of body).

40 V are permissible as the blocking voltage, and the stationary direct current load capacity $I_{F AV}$ is 3 A. The important dynamic surge current loading capacity $I_{F SM}$ important in this case is sufficient for the selected SITOP power supply (more than 100 A for 8.3 ms). For SITOP power supplies with a low rated output current, this diode can also be used, but is over-dimensioned.

- Manufacturer: General Instrument
- Distributor: e.g. RS Components, Spoerle

¹⁾ We do not accept any liability for this diode recommendation.

Battery charging with SITOP power supplies

The SITOP modular power supplies 5 A to 40 A with stabilized output voltage that can be set between 24.0 V and 28.8 V supply a constant output current of approximately 1.2 x rated current under overload conditions (e.g. a completely discharged 24 V lead-acid battery). In the case of a V/I characteristic set for parallel operation, the battery will be charged with a constant current until approximately 95% of the set SITOP output voltage has been achieved. The charging current is then continuously reduced from 1.2 x rated current at 95% of the set voltage to approx. 0 A or the self-discharge current of the battery at 100% of the set output voltage, i.e. resistance characteristic in this range.

As reverse voltage protection and polarity reversal protection, we recommend that a diode suitable for at least 1.2 x rated current of the power supply with a blocking voltage of at least 40 V is connected in series with the + output (anode connected to + output of the SITOP modular and cathode connected to positive pole of the battery).

The output voltage of the power supply must be set at no-load to the end-of-charge voltage plus the voltage drop at the diode. For an end-of-charge voltage of e.g. 27.0 V DC (usual at 20 °C to 30 °C battery temperature; in each case, compliance with the specifications of the battery manufacturer must be observed!) and 0.8 V voltage drop at the diode, SITOP modular must be set to 27.8 V during no-load operation.

Fusing of 24 V power supply circuits and selectivity

With unstabilized rectifiers (power transformer equipped with rectifier) the output usually had to be protected with a suitable fuse so that its rectifier diodes would not fail in the event of an overload or a short-circuit (this would destroy the DC loads due to the resulting alternating voltage and lead to serious damage in most cases).

On the other hand, the stabilized SITOP power supplies comply with the standard applicable to the electrical equipment of machines DIN VDE 0113 Part 1, Section 7.2.9 (November 1998) or EN 60204-1 and are provided with integral electronic short-circuit protection which automatically protects both the power supply and the supplied 24 V DC circuits against an excess current in the event of an overload/short-circuit. A differentiation must be made between the following three cases with respect to fusing on the secondary side:

Example 1: No fusing

Fusing the secondary side (24 V DC) for protecting the load circuits and lines is not required if the respective cross-sections are selected for the maximum possible output current RMS value. Depending on the event (short-circuit or overload) this may either be the short-circuit RMS value or the current limitation value.

Example SITOP power 10 (Order No.: 6EP1334-2BA00)

- Rated current 10 A
- Current limitation typ. 13 to 15 A
- Short-circuit RMS value < 21 A

The technical specifications usually specify typical values, maximum values are approx. 2 A above the typical value. In the example here, a maximum possible output current RMS value of approx. 23 A must therefore be used for line dimensioning.

Example 2: Reduced cross-sections

If smaller cross-sections are used than specified in DIN VDE 0113 Part 1 or EN 60204-1, the associated 24 V load supply lines must be provided with appropriate line protection (see DIN VDE 0113 Part 1 or EN 60204-1).

It is then unimportant whether the power supply enters current limiting mode (overload) or delivers the maximum short-circuit current (low-resistance short-circuit). The load supply line is in any case protected against an overload by the line protection matched to the conductor cross-section.

General note for using SITOP power supplies as a battery charging unit

When SITOP modular is used as a battery charging unit, the regulations of VDE 0510 or the relevant national regulations must be observed and adequate ventilation must be provided. The SITOP modular power supplies are designed as rack-mounting units, and protection against electric shock should therefore be provided by installation in an appropriate housing.

The value recommended by the battery manufacturer must be set as the end-of-charge voltage (depending on the battery temperature). An ideal temperature for the lead-acid battery is between +20 and 30 °C and the recommended end-of-charge voltage in this case is usually about 27 V.

Example 3: Selectivity

In cases where a load which has failed (e.g. because of a short-circuit) has to be rapidly detected or where it is essential to selectively switch it off before the power supply enters current limiting mode (with current limiting mode, the voltage would also fall for all remaining 24 V DC loads), there are two possibilities for the secondary side connection.

- **Use of a 4-channel electronic diagnosis module SITOP select (Order No.: 6EP1961-2BA00), with a current adjustable from 2 A to 10 A for each channel**
- Series connection of appropriate 24 V DC fuses or circuit-breakers

The basis for selection of the 24 V DC fuse or circuit-breaker is the short-circuit current above the rated current which the SITOP power supplies deliver in the event of a short-circuit during operation (values are specified in the respective technical specifications under "Output, dynamic V/I on short-circuit during operation").

It is not easy to calculate the amount of the short-circuit current flowing into the usually not ideal "short-circuit" and the amount flowing into the remaining loads. This depends on the type of overload (high-resistance or low-resistance short-circuit) and the type of load connected (resistive, inductive and capacitive/electronic loads).

However, it can be assumed with a first approximation in the average case encountered in practice that the difference of dyn. V/I minus 50% SITOP rated output current is available for the immediate tripping of a circuit-breaker within a typical time of 12 ms (with 14 times the rated DC with a circuit-breaker characteristic C acc. to IEC 898 or with 7 times the rated DC with a circuit-breaker characteristic B or with 5 times the rated DC with a circuit-breaker characteristic A). Please refer to the following tables for circuit-breakers appropriate for selected fusing according to this assumption.

Technical information and configuration

Fusing of the output circuit 24 V DC, selectivity

List of ordering data and tripping characteristics of single-pole circuit-breakers 5SY4...

acc. to IEC 898/EN 60898 (DIN VDE 0641 Part 11), for use up to 60 V DC (250 V AC, switching capacity 10,000 A)

Rated current	Tripping characteristic	Order No.	Range for immediate tripping < 100 ms for operation with direct current (alternating current)	Required DC for immediate tripping in < 100 ms	Required DC for immediate tripping in approx. 12 ms
1 A	Type A	5SY4 101-5	DC: 2 to 5 (AC: 2 to 3) × I_{rated}	2 to 5 A DC	5 A DC
1 A	Type C	5SY4 101-7	DC: 5 to 14 (AC: 5 to 10) × I_{rated}	5 to 14 A DC	14 A DC
1.6 A	Type A	5SY4 115-5	DC: 2 to 5 (AC: 2 to 3) × I_{rated}	3.2 to 8 A DC	8 A DC
1.6 A	Type C	5SY4 115-7	DC: 5 to 14 (AC: 5 to 10) × I_{rated}	8 to 22.4 A DC	22.4 A DC
2 A	Type A	5SY4 102-5	DC: 2 to 5 (AC: 2 to 3) × I_{rated}	4 to 10 A DC	10 A DC
2 A	Type C	5SY4 102-7	DC: 5 to 14 (AC: 5 to 10) × I_{rated}	10 to 28 A DC	28 A DC
3 A	Type A	5SY4 103-5	DC: 2 to 5 (AC: 2 to 3) × I_{rated}	6 to 15 A DC	15 A DC
3 A	Type C	5SY4 103-7	DC: 5 to 14 (AC: 5 to 10) × I_{rated}	15 to 42 A DC	42 A DC
4 A	Type A	5SY4 104-5	DC: 2 to 5 (AC: 2 to 3) × I_{rated}	8 to 20 A DC	20 A DC
4 A	Type C	5SY4 104-7	DC: 5 to 14 (AC: 5 to 10) × I_{rated}	20 to 56 A DC	56 A DC
6 A	Type A	5SY4 106-5	DC: 2 to 5 (AC: 2 to 3) × I_{rated}	12 to 30 A DC	30 A DC
6 A	Type B	5SY4 106-6	DC: 3 to 7 (AC: 3 to 5) × I_{rated}	18 to 42 A DC	42 A DC
6 A	Type C	5SY4 106-7	DC: 5 to 14 (AC: 5 to 10) × I_{rated}	30 to 84 A DC	84 A DC
8 A	Type A	5SY4 108-5	DC: 2 to 5 (AC: 2 to 3) × I_{rated}	16 to 40 A DC	40 A DC
8 A	Type C	5SY4 108-7	DC: 5 to 14 (AC: 5 to 10) × I_{rated}	40 to 112 A DC	112 A DC
10 A	Type A	5SY4 110-5	DC: 2 to 5 (AC: 2 to 3) × I_{rated}	20 to 50 A DC	50 A DC
10 A	Type B	5SY4 110-6	DC: 3 to 7 (AC: 3 to 5) × I_{rated}	30 to 70 A DC	70 A DC
10 A	Type C	5SY4 110-7	DC: 5 to 14 (AC: 5 to 10) × I_{rated}	50 to 140 A DC	140 A DC
13 A	Type A	5SY4 113-5	DC: 2 to 5 (AC: 2 to 3) × I_{rated}	26 to 65 A DC	65 A DC
13 A	Type B	5SY4 113-6	DC: 3 to 7 (AC: 3 to 5) × I_{rated}	39 to 91 A DC	91 A DC
13 A	Type C	5SY4 113-7	DC: 5 to 14 (AC: 5 to 10) × I_{rated}	65 to 182 A DC	182 A DC
16 A	Type A	5SY4 116-5	DC: 2 to 5 (AC: 2 to 3) × I_{rated}	32 to 80 A DC	80 A DC
16 A	Type B	5SY4 116-6	DC: 3 to 7 (AC: 3 to 5) × I_{rated}	48 to 112 A DC	112 A DC
16 A	Type C	5SY4 116-7	DC: 5 to 14 (AC: 5 to 10) × I_{rated}	80 to 224 A DC	224 A DC

Ordering data and tripping characteristics of Siemens single-pole circuit-breaker terminals type 8WA1 011-...

Suitable for up to 60 V DC (250 V AC)

The following space-saving circuit-breaker terminals for mere short-circuit protection can only be snap-mounted on DIN rail EN 50 022-35x15. They are also available with an auxiliary switch (1 NO contact and 1 NC contact) and feature higher sensitivity than circuit breakers acc. to IEC 898 (EN 60 898), type B.

Tripping times/ranges are within narrower tolerances than those of circuit-breakers. When operated with DC, these circuit-breaker terminals do not trip at currents below the rated current, from 1.1 times the rated current, the circuit-breaker terminal may trip after as little as 100 ms.

The circuit-breaker rated value must therefore be above the load inrush current peak value. In general, however, the first three milliseconds of the load inrush current may be ignored because no less than 20 to 100 times the rated current is required to trip the circuit-breaker terminals during this period of time.

- The circuit-breaker terminals already trip after 40 ms at 1.2 to 1.9 times the rated DC.
- The circuit-breaker terminals already trip after 20 ms at 1.7 to 2.6 times the rated DC.
- The circuit-breaker terminals already trip after 12 ms at 2.2 to 3.8 times the rated DC.

Ordering data and tripping characteristics of Siemens single-pole circuit-breaker terminals type 8WA1 011-...

Rated current DC	2 A	4 A	6 A	10 A
Order No. (without auxiliary switch)	8WA1 011-1SF25	8WA1 011-1SF26	8WA1 011-1SF27	8WA1 011-1SF28
Order No. (with auxiliary switch 1 NO + 1 NC)	8WA1 011-6SF25	8WA1 011-6SF26	8WA1 011-6SF27	8WA1 011-6SF28
Required DC for immediate tripping in 40 ms	2.4 to 3.8 A	4.8 to 7.6 A	7.2 to 11.4 A	12 to 19 A
Required DC for immediate tripping in 20 ms	3.4 to 5.2 A	6.8 to 10.7 A	10.2 to 15.6 A	17 to 26 A
Required DC for immediate tripping in approx. 12 ms	4.4 to 7.6 A	8.8 to 15.2 A	13.2 to 22.8 A	22 to 38 A

For more data, refer to catalog "Industrial switchgear" (Catalog LV 10)

Technical information and configuration

Fusing of the output circuit 24 V DC, selectivity

Miniature circuit-breakers in 24 V DC circuits which are powered by SITOP power supply units

Technical specifications

Type	5 A	10 A
Order No.	6EP1 333-3BA00	6EP1 334-3BA00
Input	Single-phase, two-phase	Single-phase, two-phase
Rated voltage $V_{in \text{ rated}}$	120/230-500 V AC	120/230-500 V AC
Output	Stabilized, floating direct voltage	Stabilized, floating direct voltage
Rated voltage $V_{out \text{ rated}}$	24 V DC	24 V DC
Rated current $I_{out \text{ rated}}$	5 A	10 A
Dyn. V/I with short-circuit in operation, typ.	15 A for 25 ms	30 A for 25 ms
Tripping of output m.c.b	The following are approximately available for selective tripping in practice	
SITOP, dyn. V/I - 50% $I_{out \text{ rated}}$, typ.	12.5 A for 25 ms	25 A for 25 ms
CBs to IEC 898, type 5SY4 1..., selectively trippable in approx. 12 ms	1 A Type A (trips at 5 A DC after typ. 12 ms)	-
	-	1 A Type C (trips at 14 A DC after typ. 12 ms)
	1.6 A Type A (trips at 8 A DC after typ. 12 ms)	-
	-	1.6 A Type C (trips at 22.4 A DC after typ. 12 ms)
	2 A Type A (trips at 10 A DC after typ. 12 ms)	-
	-	3 A Type A (trips at 15 A DC after typ. 12 ms)
Siemens CB terminals, Type 8WA1 011..., selectively trippable in approx. 12 ms	-	4 A Type A (trips at 20 A DC after typ. 12 ms)
	2 A Order No. 8WA1 011-1SF25 (trips at 7.6 A DC after max. 12 ms)	-
	-	4 A Order No. 8WA1 011-1SF26 (trips at 15.2 A DC after max. 12 ms)
	-	6 A Order No. 8WA1 011-1SF27 (trips at 22.8 A DC after max. 12 ms)
in 20 ms	4 A Order No. 8WA1 011-1SF26 (trips at 10.7 A DC after max. 20 ms)	-

Technical information and configuration

Fusing of the output circuit 24 V DC, selectivity

Miniature circuit-breakers in 24 V DC circuits which are powered by SITOP power supply units

Technical specifications		
Type	20 A	40 A
Order No.	6EP1 436-2BA00	6EP1 437-2BA10
Input	Three-phase	Single-phase, two-phase
Rated voltage $V_{in rated}$	400-500 V 3 AC	400-500 V AC
Output	Stabilized, floating direct voltage	Stabilized, floating direct voltage
Rated voltage $V_{out rated}$	24 V DC	24 V DC
Rated current $I_{out rated}$	20 A	40 A
Dyn. V/I with short-circuit in operation, typ.	Approx. 30 A constant current	70 A for 600 ms
Tripping of output m.c.b	The following are approximately available for selective tripping in practice	
SITOP, dyn. V/I - 50% $I_{out rated}$, typ.	20 A (without interruption)	50 A for 600 ms
CBs to IEC 898, type 5SY4 1..., selectively trippable in approx. 12 ms	1 A Type A (trips at 5 A DC after typ. 12 ms)	
	1 A Type C (trips at 14 A DC after typ. 12 ms)	
	1.6 A Type A (trips at 8 A DC after typ. 12 ms)	
	-	1.6 A Type C (trips at 22.4 A DC after typ. 12 ms)
	2 A Type A (trips at 10 A DC after typ. 12 ms)	
	-	2 A Type C (trips at 28 A DC after typ. 12 ms)
	3 A Type A (trips at 15 A DC after typ. 12 ms)	
	-	3 A Type C (trips at 42 A DC after typ. 12 ms)
	4 A Type A (trips at 20 A DC after typ. 12 ms)	
	-	6 A Type A (trips at 30 A DC after typ. 12 ms)
	-	6 A Type B (trips at 42 A DC after typ. 12 ms)
	-	8 A Type A (trips at 40 A DC after typ. 12 ms)
	-	10 A Type A (trips at 50 A DC after typ. 12 ms)
Siemens CB terminals, Type 8WA1 011..., selectively trippable in approx. 12 ms	2 A Order No. 8WA1 011-1SF25 (trips at 7.6 A DC after max. 12 ms)	
	4 A Order No. 8WA1 011-1SF26 (trips at 15.2 A DC after max. 12 ms)	
	-	6 A Order No. 8WA1 011-1SF27 (trips at 22.8 A DC after max. 12 ms)
	-	10 A Order No. 8WA1 011-1SF28 (trips at 38 A DC after max. 12 ms)

Technical information and configuration

Notes

14



Dimension drawings

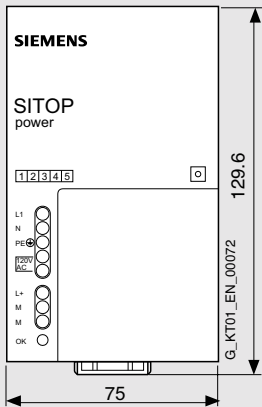

- 15/2 SITOP power
Single-, two-, three-phase
- 15/9 SITOP power
Additional components
- 15/11 SITOP power
Uninterruptible power supplies
- 15/13 SITOP power
Alternative voltages
- 15/14 SITOP power
AS interface power supplies
- 15/15 LOGO!Power



Dimension drawings

SITOP power Single-, two-, three-phase

Dimensions in mm

Order No.: **6EP1 331-2BA10, 6EP1 731-2BA00**

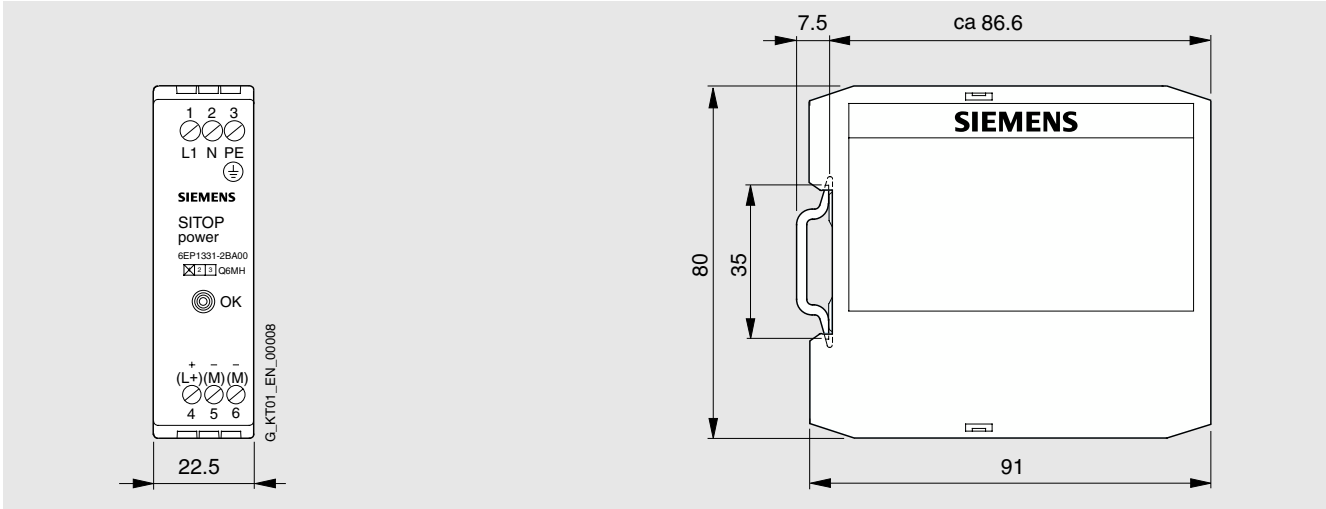

Order No.: **6EP1 331-2BA00**

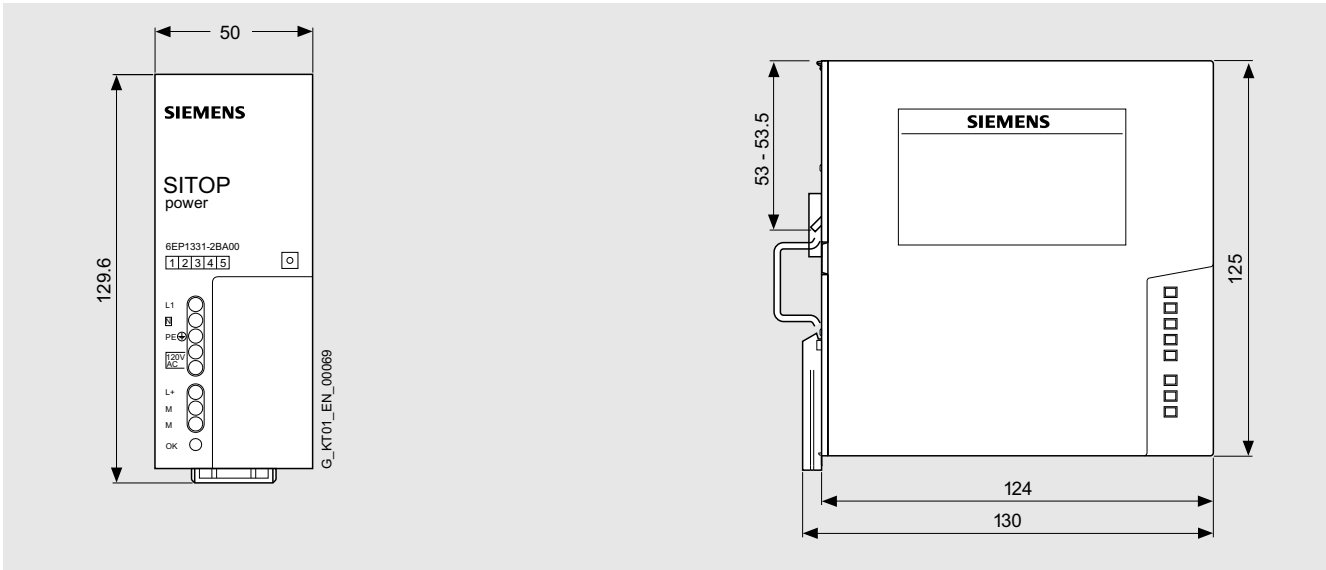

Order No.: **6EP1 331-1SL11, 6ES7 307-1BA00-0AA0**

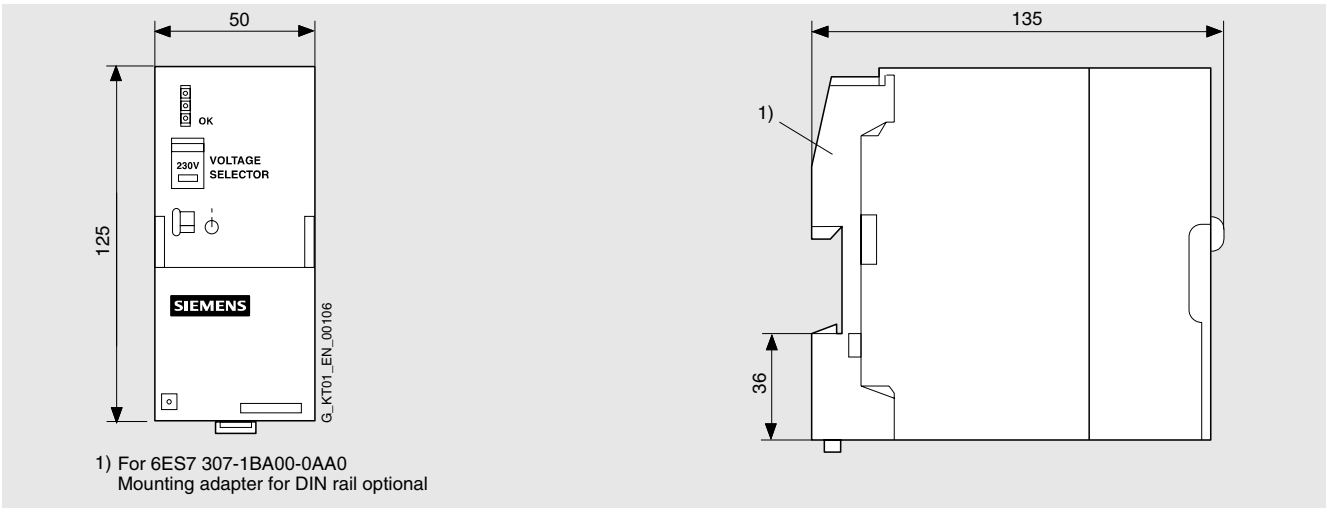

Dimension drawings

SITOP power
Single-, two-, three-phase

Dimensions in mm

Order No.: 6ES7 305-1BA80-0AA0, 6EP1 333-1SL11, 6ES7 307-1EA00-0AA0, 6ES7 307-1EA80-0AA0

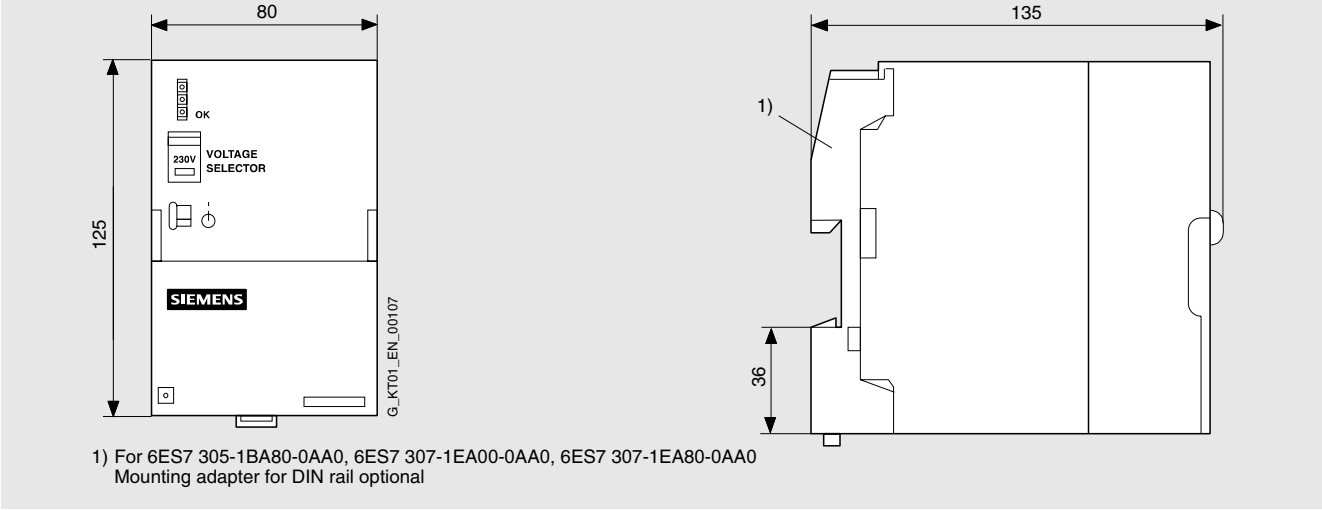

Order No.: 6EP1 732-0AA00, 6EP1 332-1SH12, 6EP1 332-1SH22

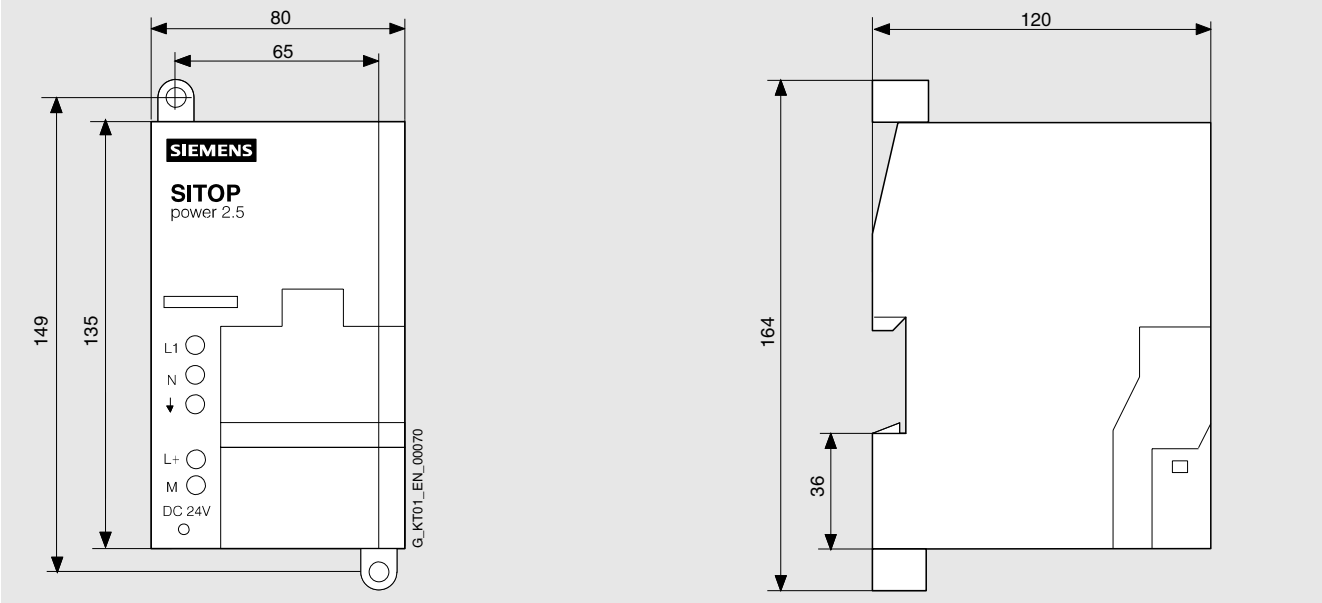

Order No.: 6EP1 332-1SH31

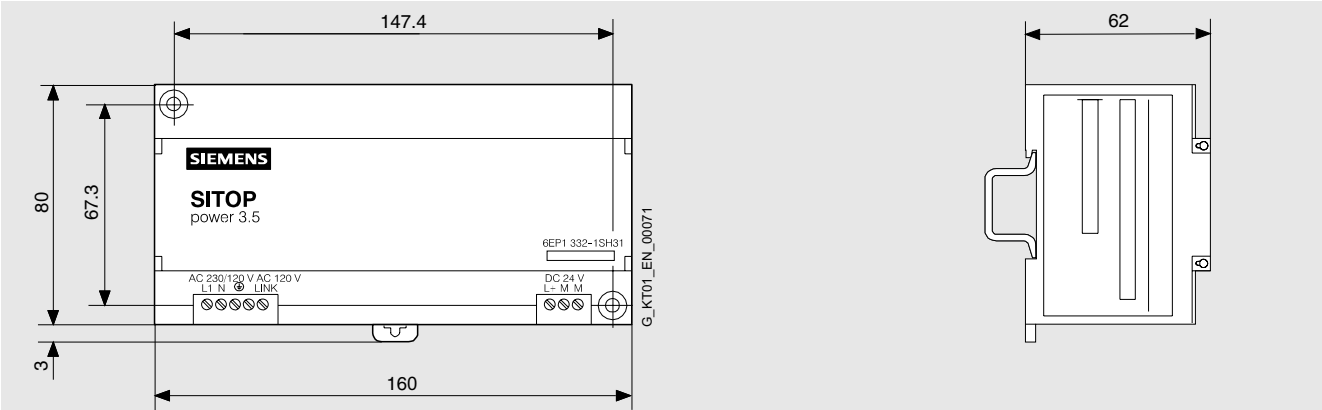

Dimension drawings

SITOP power Single-, two-, three-phase

Dimensions in mm

Order No.: **6EP1 333-3BA00**

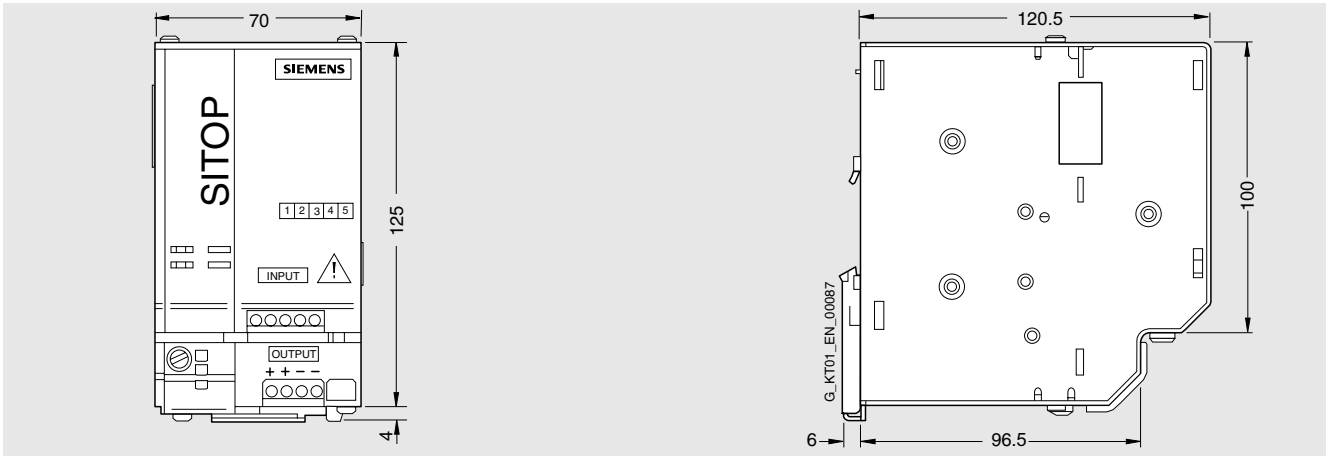

Order No.: **6EP1 333-2BA00, 6EP1 333-2AA00**

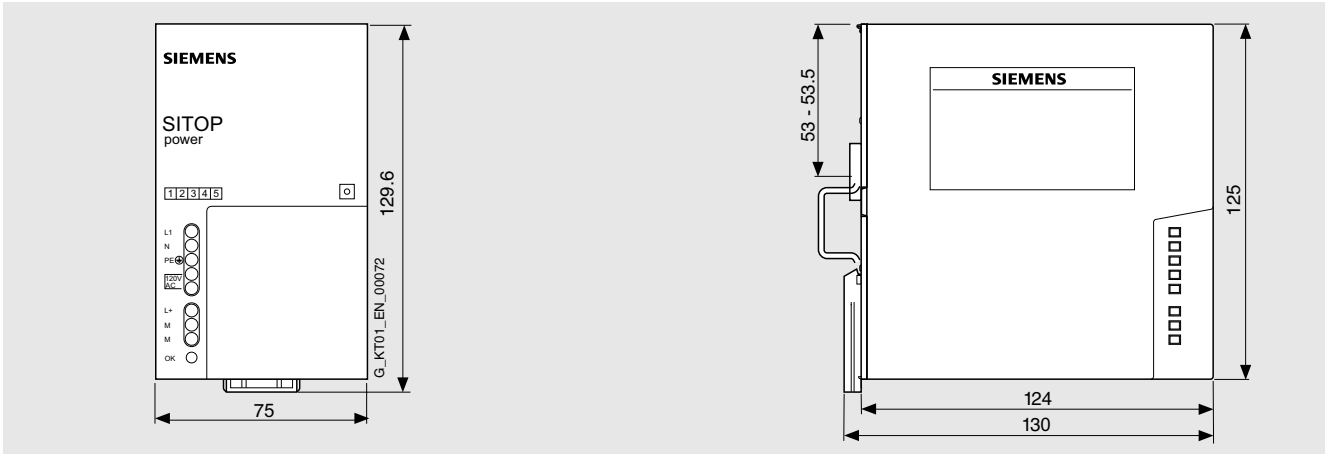

Order No.: **6EP1 333-1AL12, 6EA1 334-1AL12**

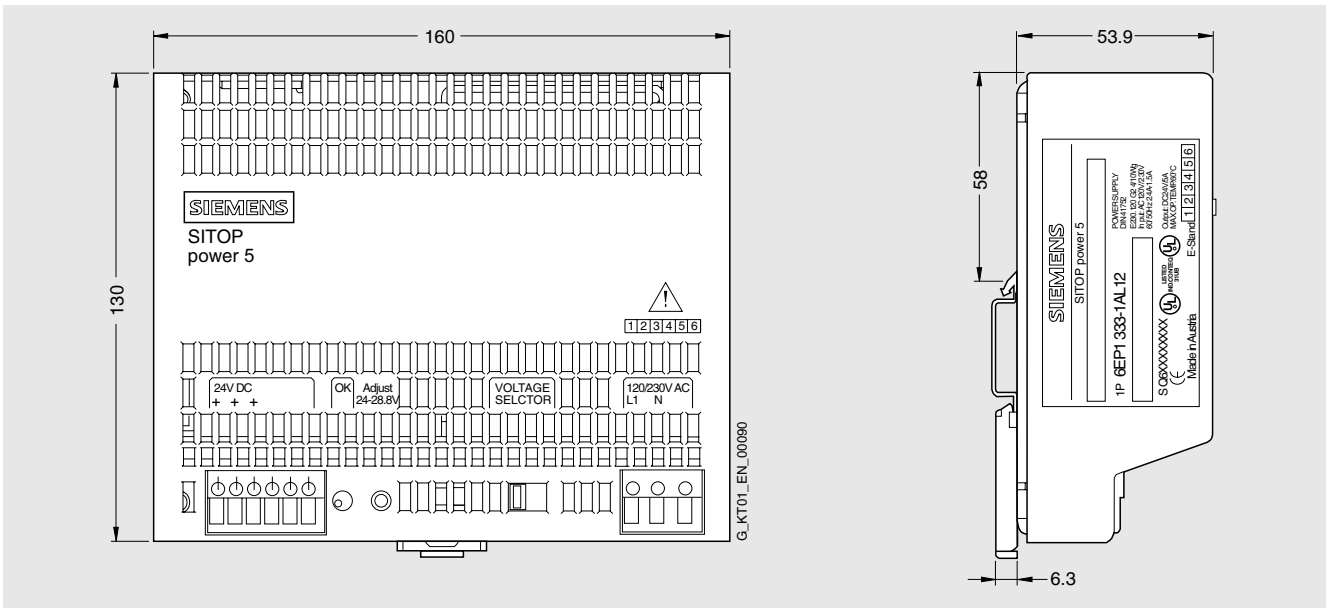

Dimension drawings

SITOP power
Single-, two-, three-phase

Dimensions in mm

Order No.: **6EP1 334-3BA00**

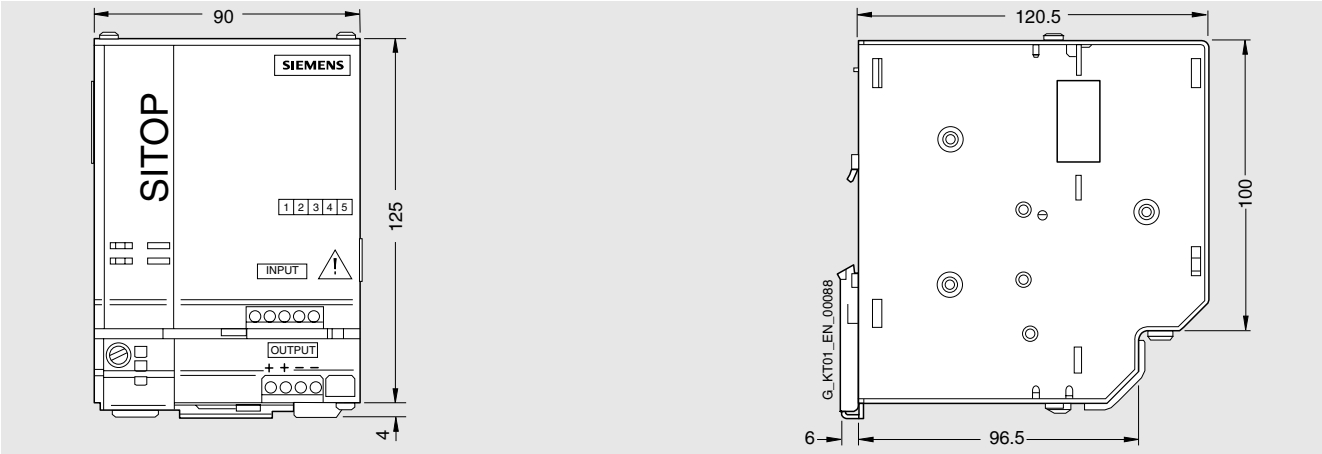

Order No.: **6EP1 334-2BA00, 6EP1 334-2AA00**

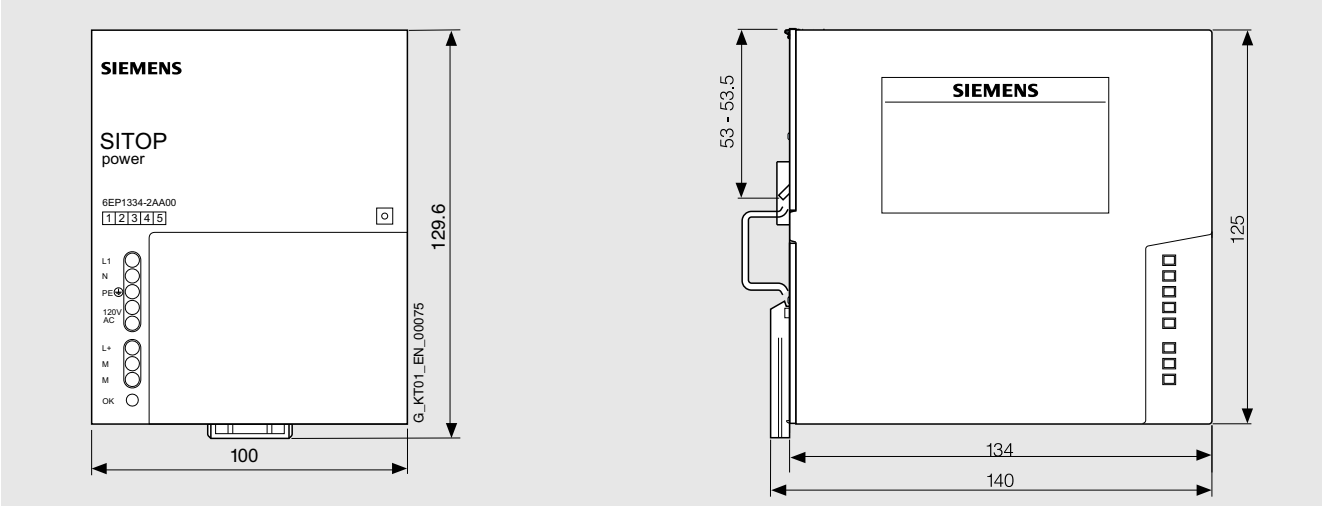

Order No.: **6EP1 334-1SL12, 6ES7 307-1KA01-0AA0, 6EP1 334-1SH01**

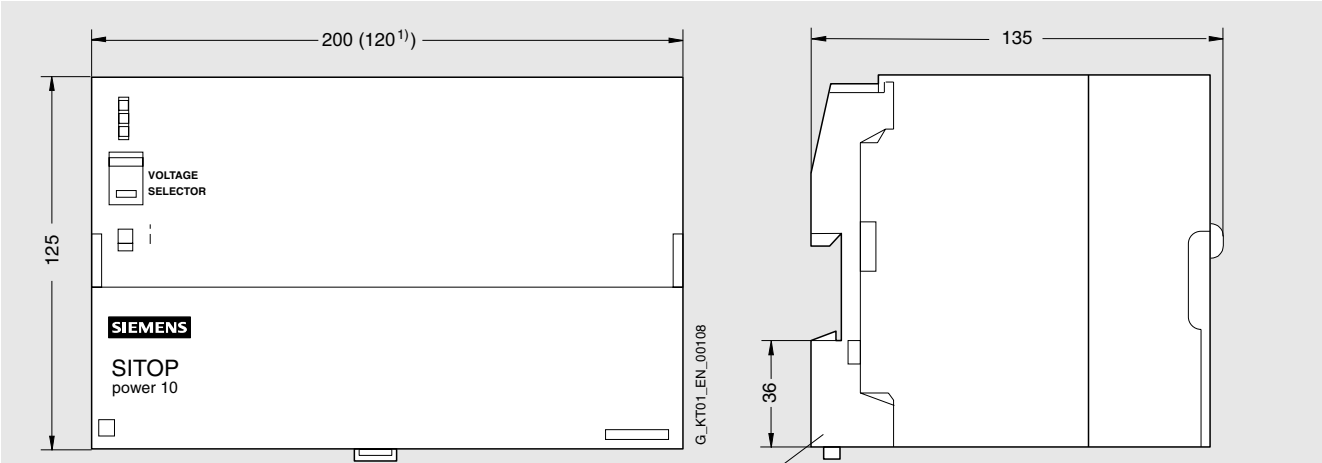

- 1) 6ES7 307-1KA01-0AA0 and 6EP1 334-1SL12
- 2) For 6ES7 307-1KA01-0AA0
Mounting adapter for DIN rail optional

Dimension drawings

SITOP power
Single-, two-, three-phase

Dimensions in mm

Order No.: 6EP1 334-2CA00

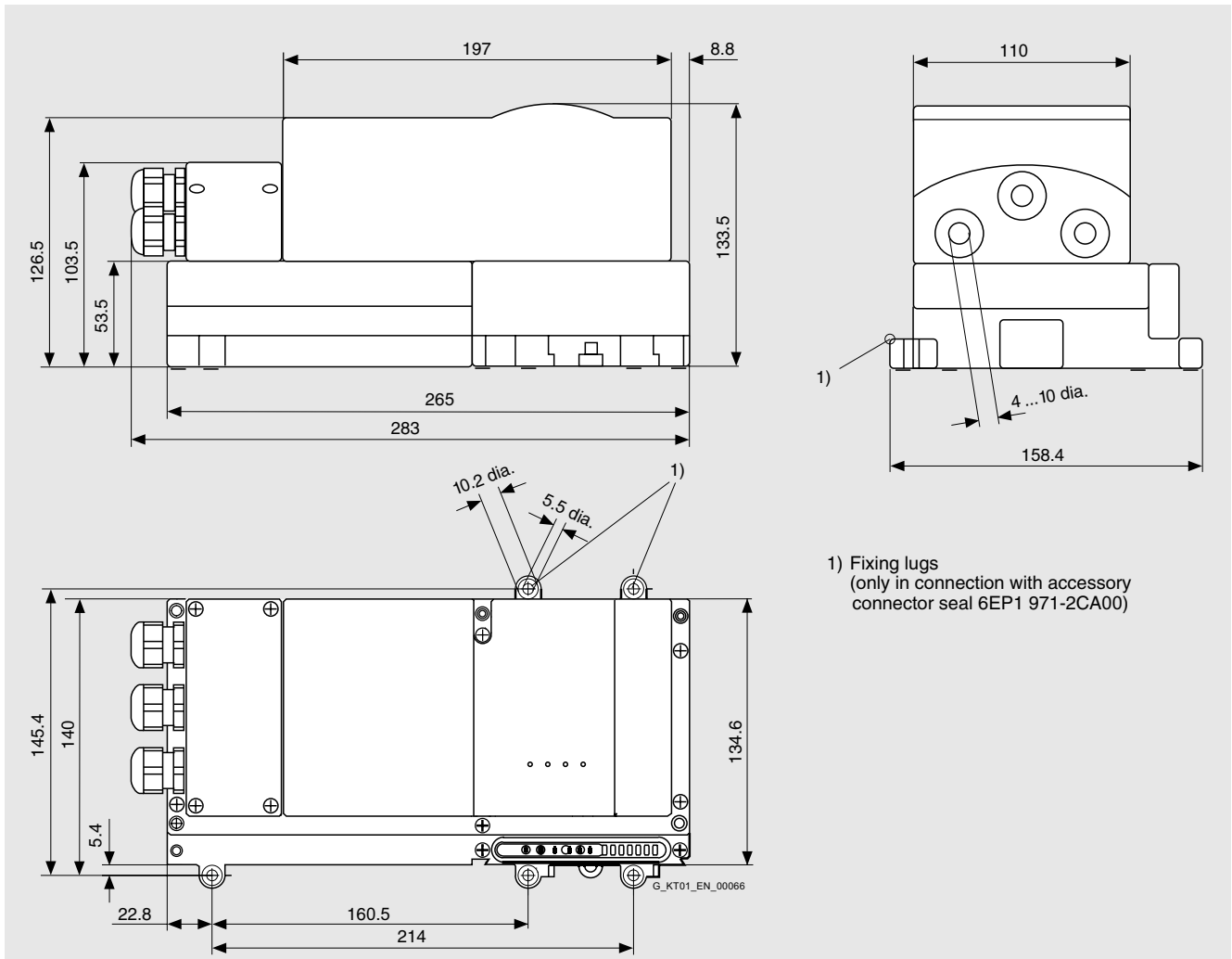

Dimension drawings

SITOP power Single-, two-, three-phase

Dimensions in mm

Order No.: 6EP1 336-3BA00, 6EP1 436-3BA00

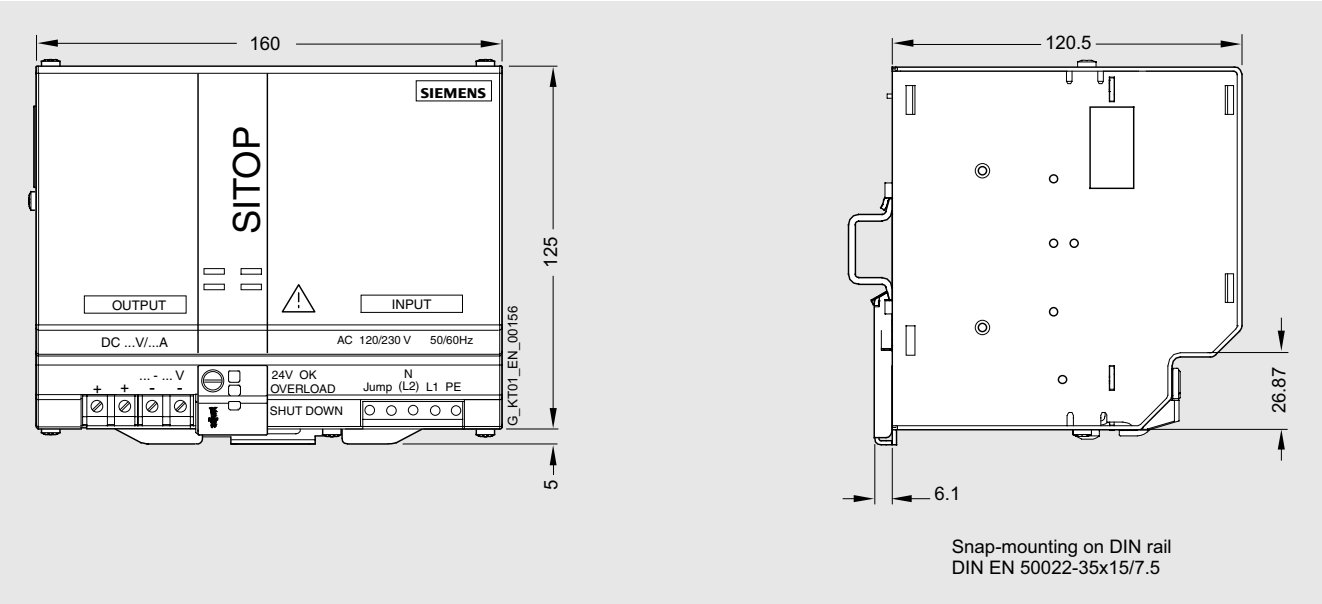

Order No.: 6EP1 337-3BA00, 6EP1 437-3BA00

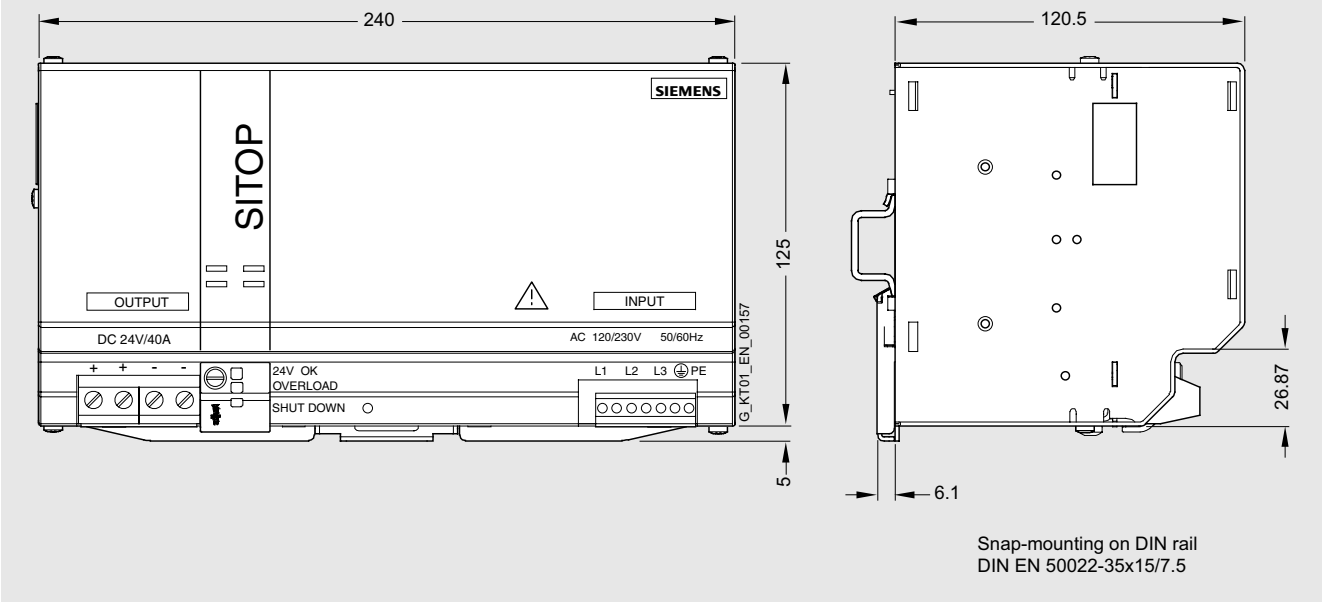

Dimension drawings

SITOP power Single-, two-, three-phase

Dimensions in mm

Order No.: 6EP1 336-2BA00, 6EP1 434-2BA00, 6EP1 436-2BA00

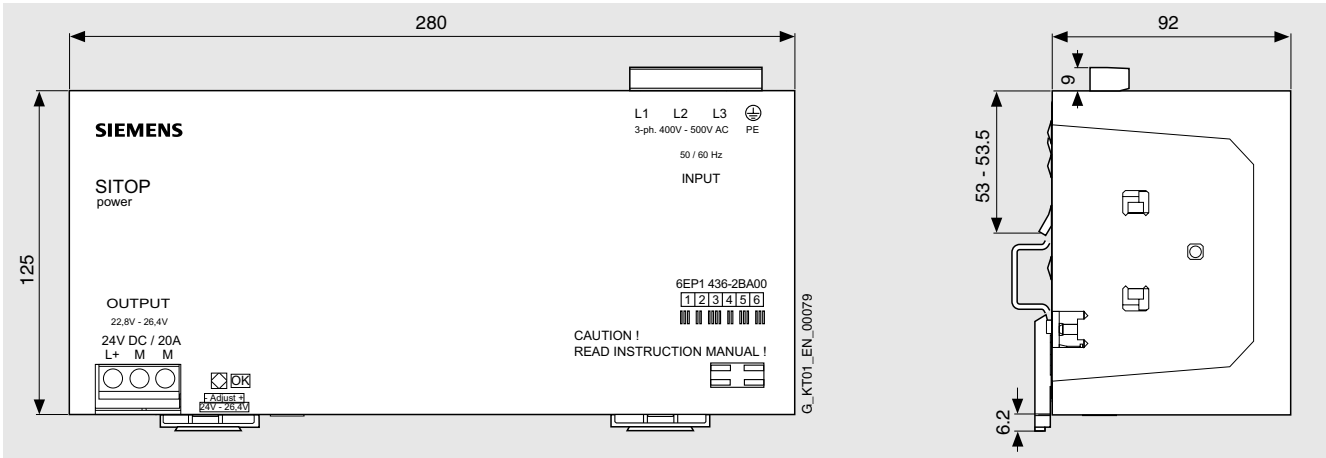

Order No.: 6EP1 536-2AA00, 6EP1 437-2BA00, 6EP1 437-2BA10

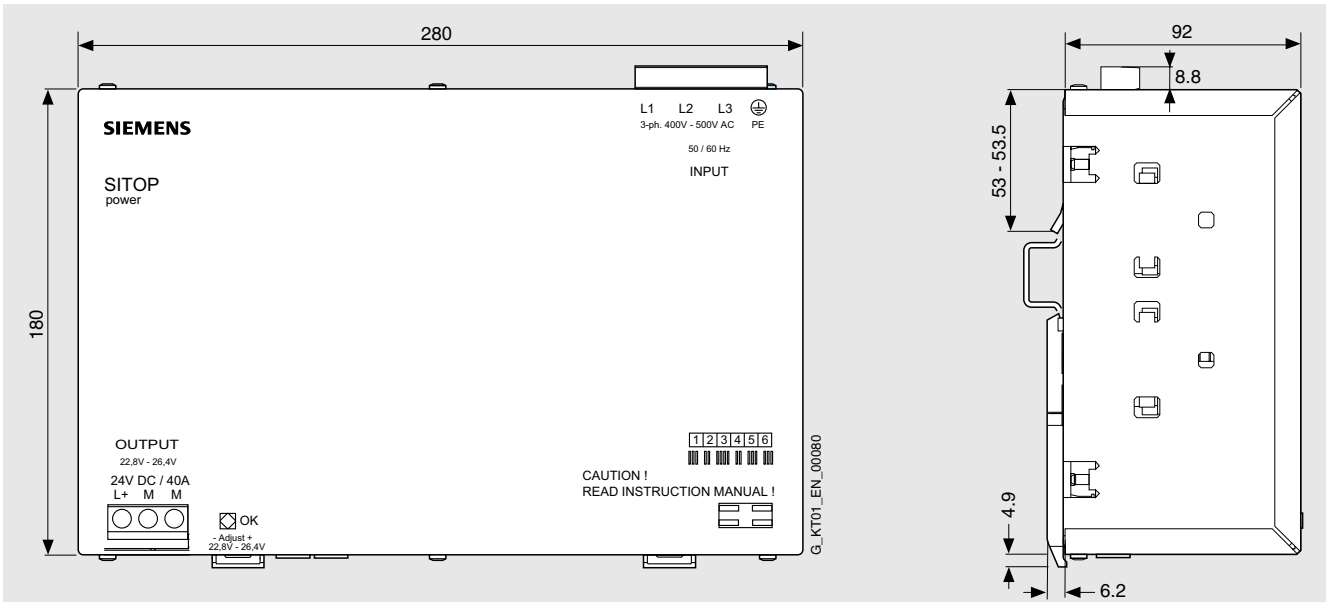

**SITOP power
Additional components**

Dimensions in mm

Order No.: **6EP1 961-3BA10**

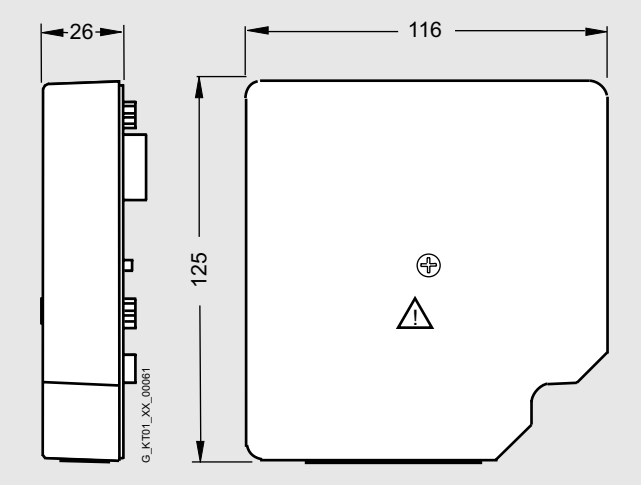

Order No.: **6EP1 961-3BA00**

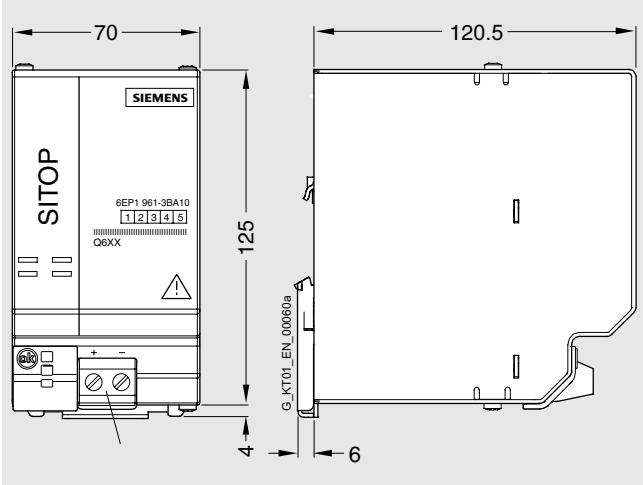

Order No.: **6EP1 961-3BA20**

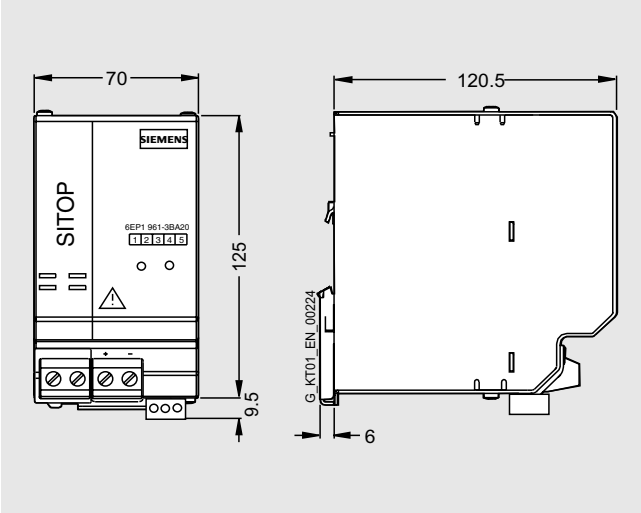

Order No.: **6EP1 961-2BA00**

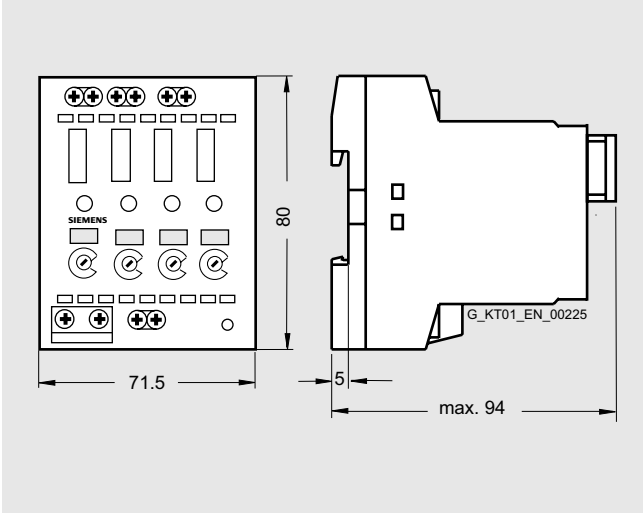

Dimension drawings

SITOP power Accessories

Dimensions in mm

Order No.: **6EP1 971-1AA01**

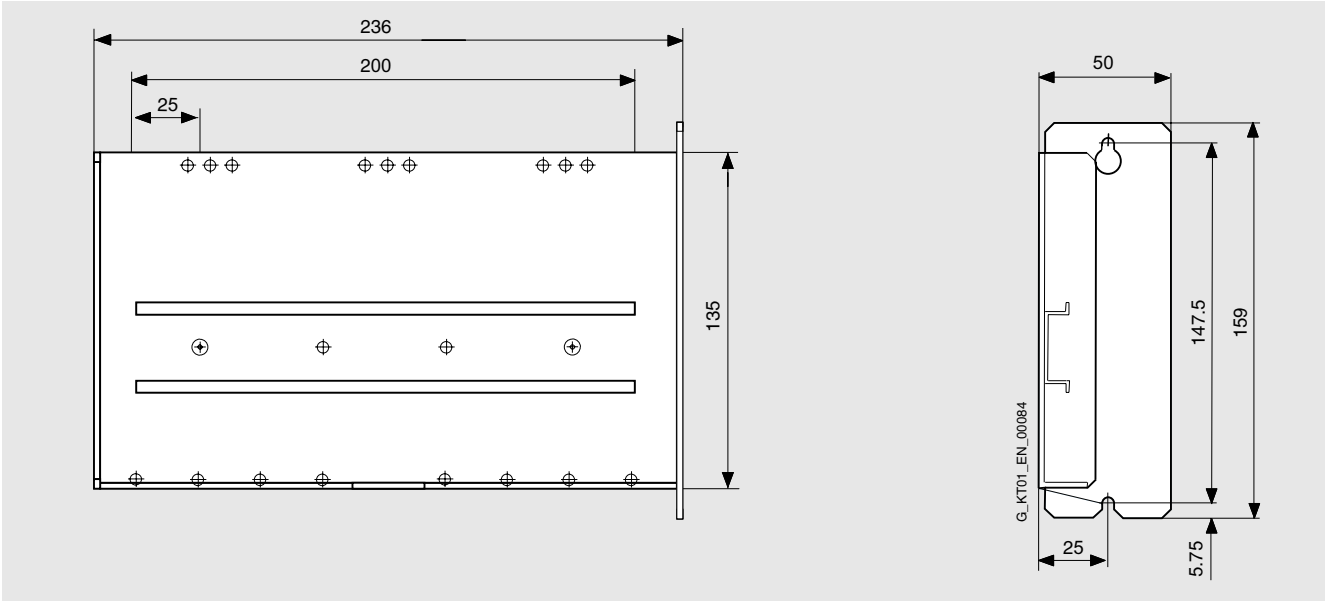

Order No.: **6EP1 971-2BA00**

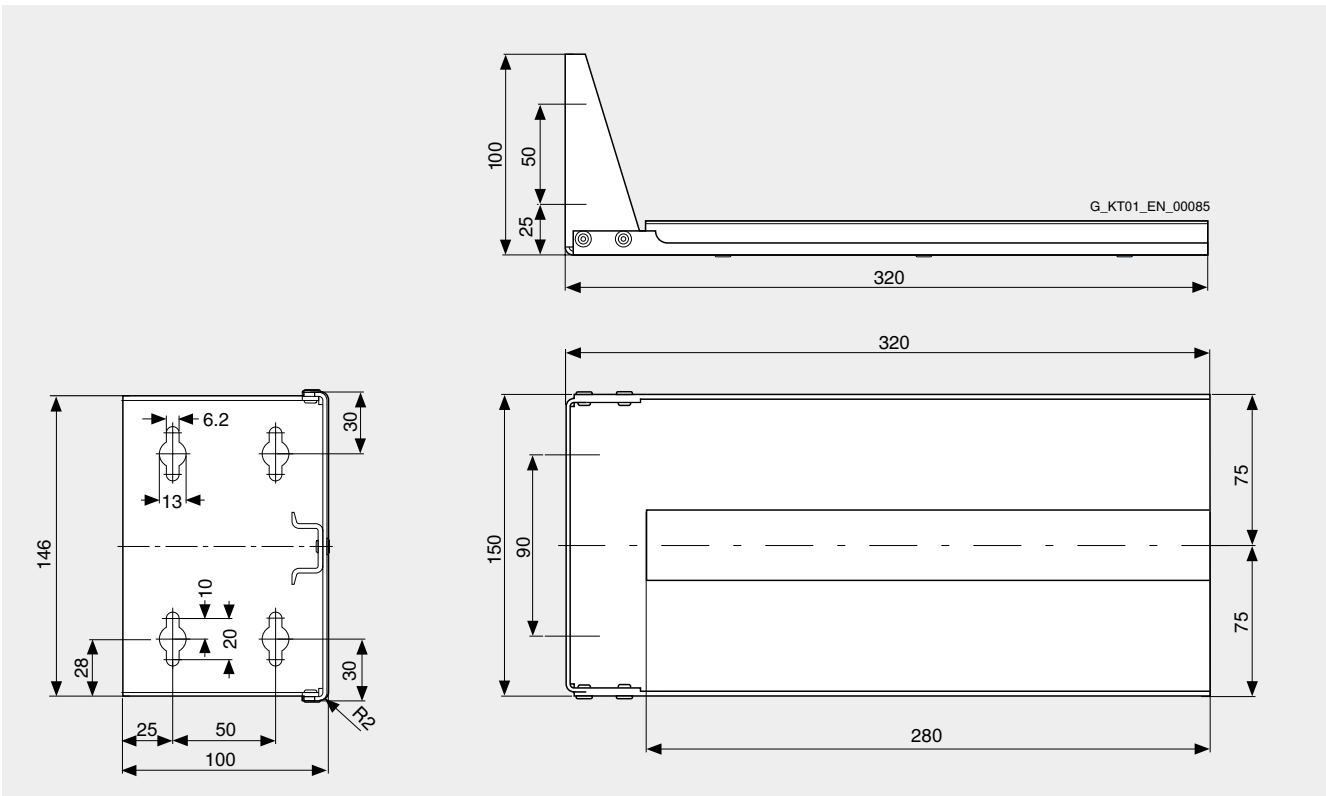

Dimensions in mm

Order No.: **6EP1 931-2DC21, 6EP1 931-2DC31, 6EP1 931-2DC41**

Order No.: **6EP1 931-2EC21, 6EP1 931-2EC31, 6EP1 931-2EC41**

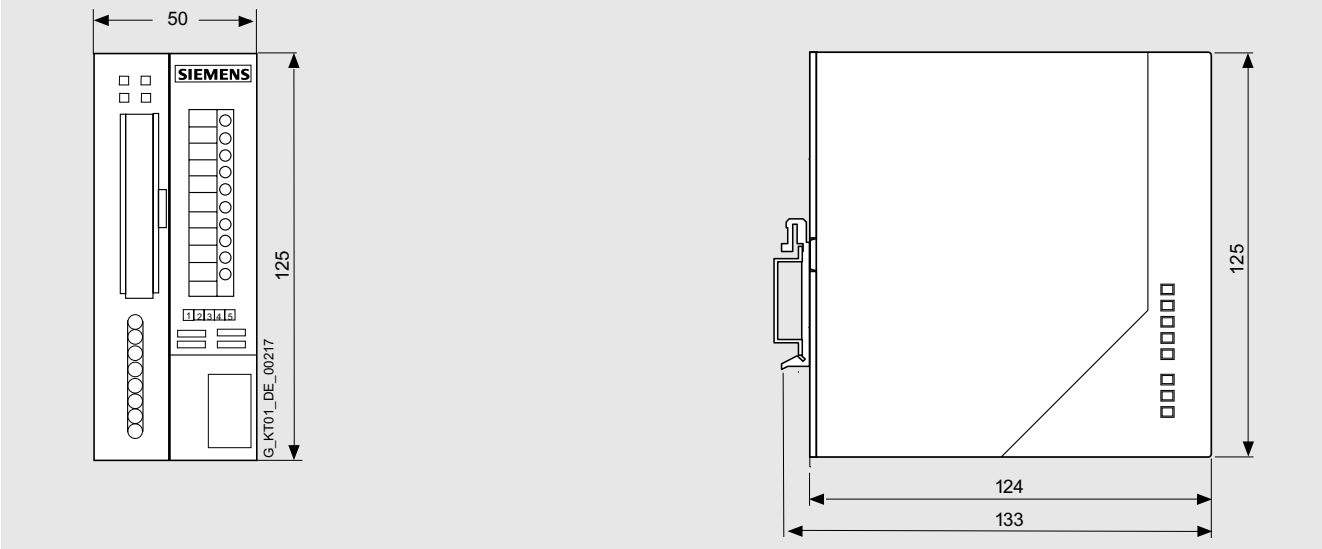

Order No.: **6EP1 931-2FC01**

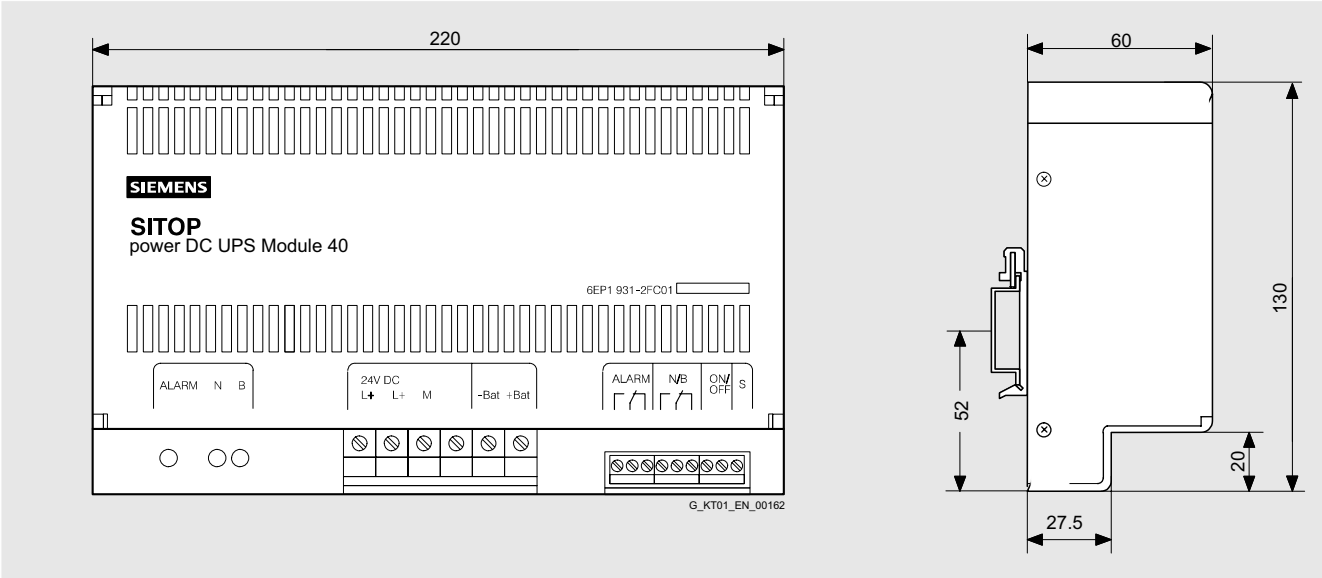

Dimension drawings

SITOP power Uninterruptible power supplies

Drilling templates

Order No.: **6EP1 935-6MD31**

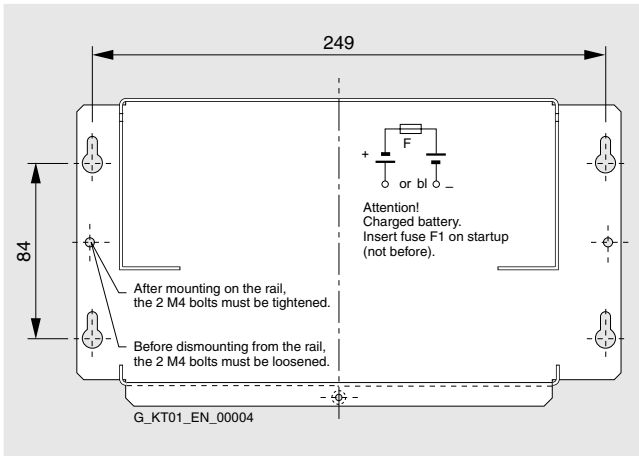

Order No.: **6EP1 935-6MD11**

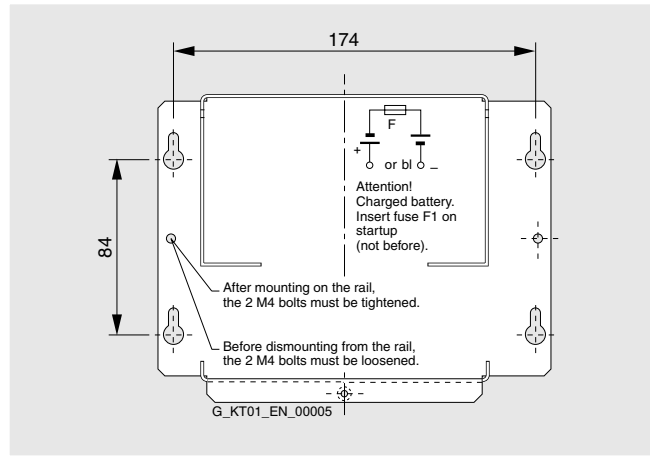

Order No.: **6EP1 935-6ME21**

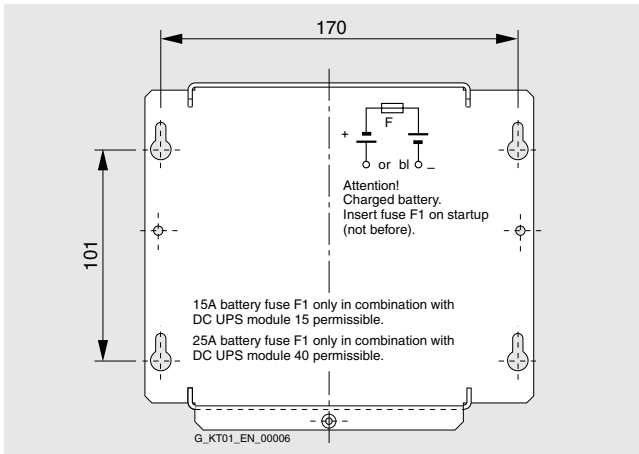

Order No.: **6EP1 935-6MF01**

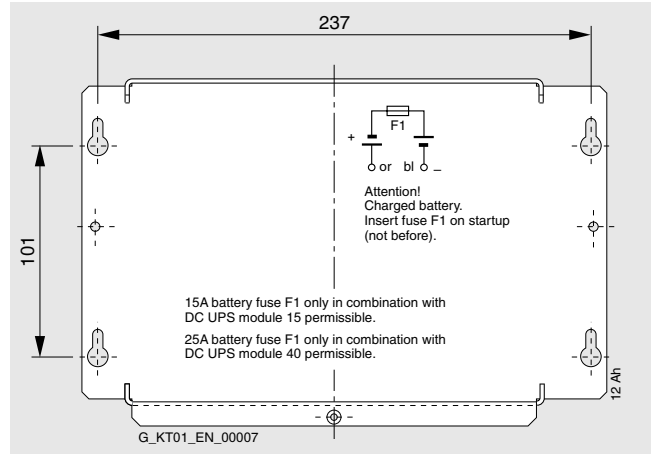

Dimension drawings

SITOP power Alternative voltages

Dimensions in mm

Order No.: **6EP1 353-2BA00, 6EP1 353-0AA00**

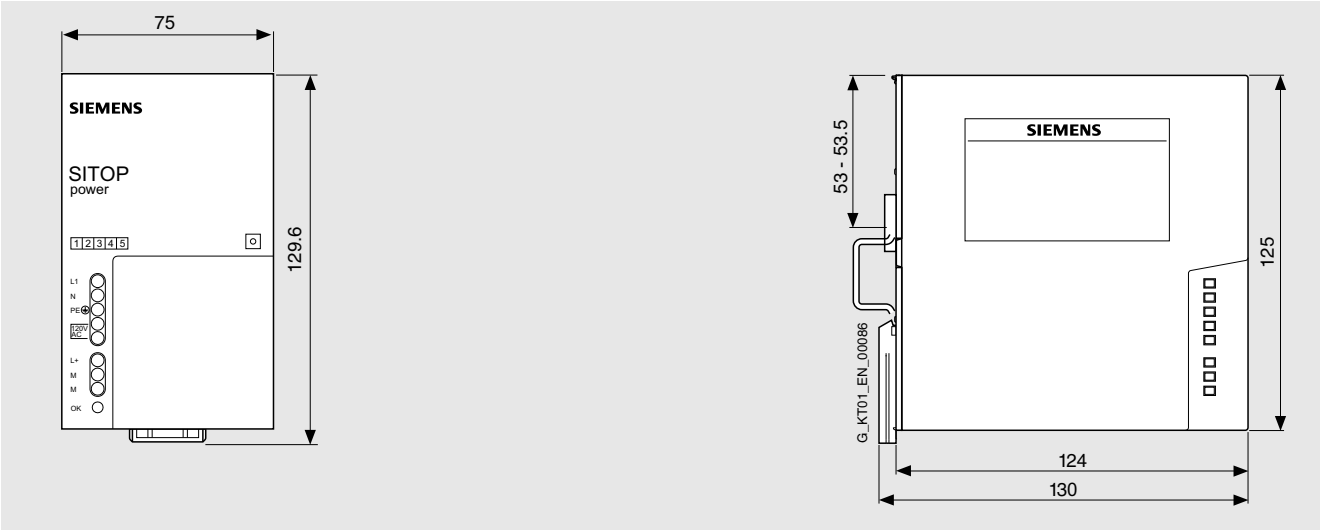

Order No.: **6EP1 457-3BA00**

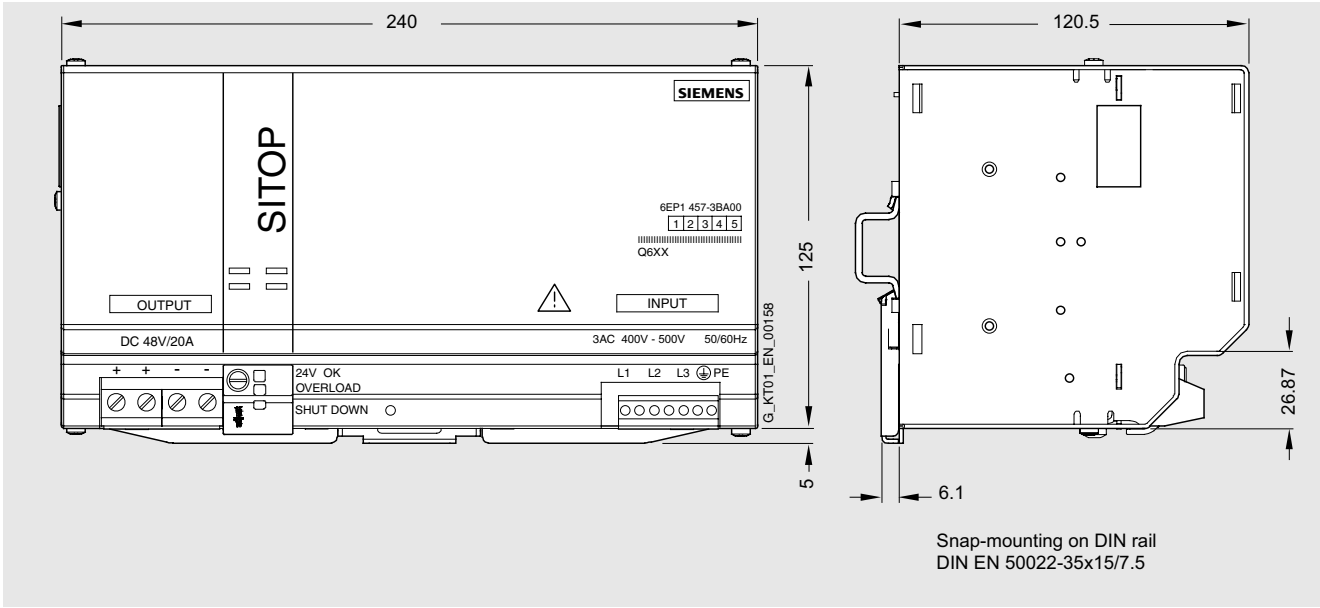

Dimension drawings

SITOP power AS interface power supplies

Dimensions in mm

Order No.: **6EP1 354-1AL01**

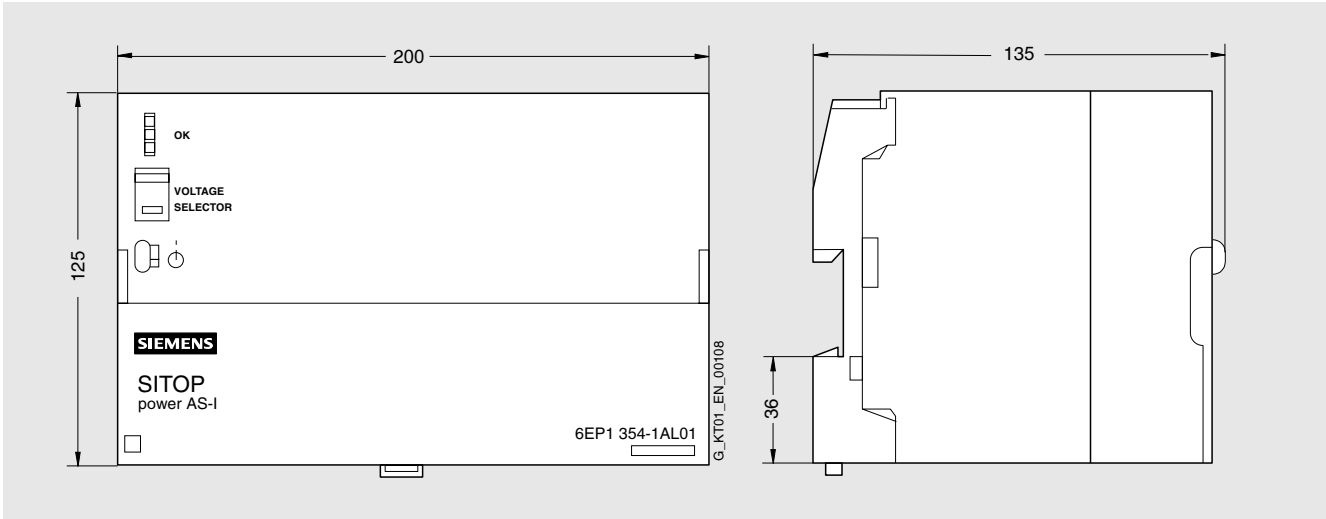

Order No.: **6EP1 632-1AL01**

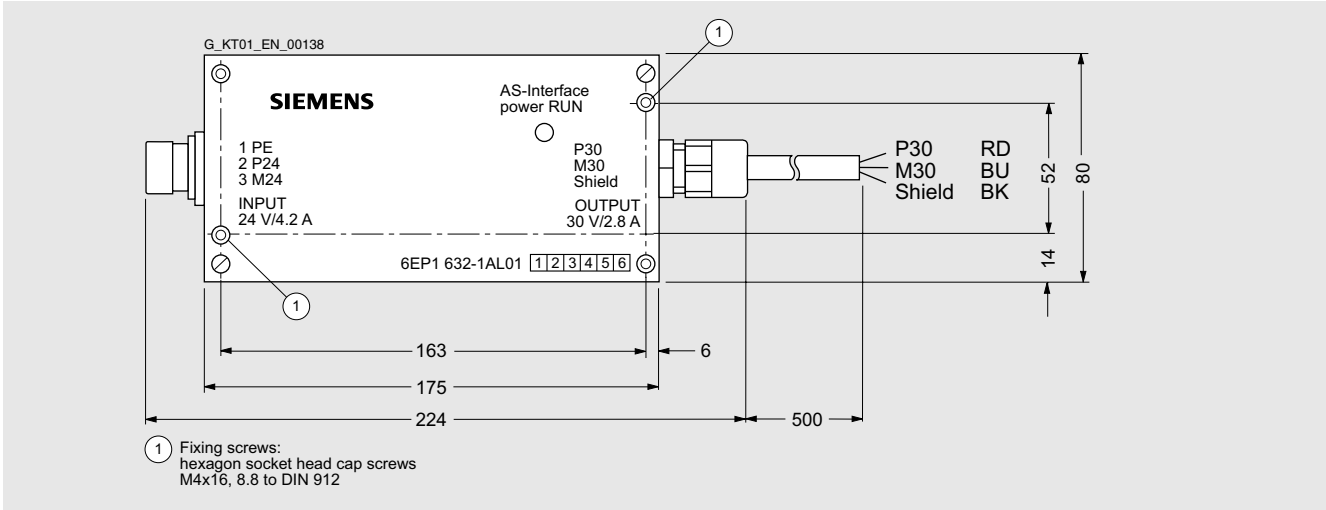

Dimensions in mm

Order No.: 6EP1 311-1SH02, 6EP1 321-1SH02, 6EP1 351-1SH02, 6EP1 331-1SH02

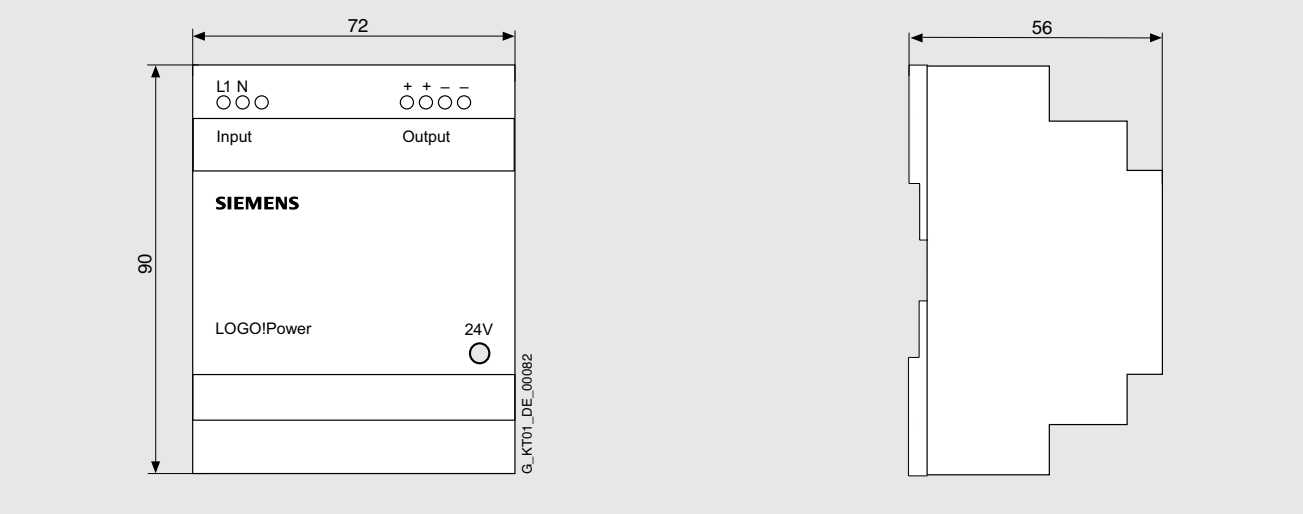

Order No.: 6EP1 311-1SH12, 6EP1 322-1SH02, 6EP1 352-1SH02, 6EP1 332-1SH42

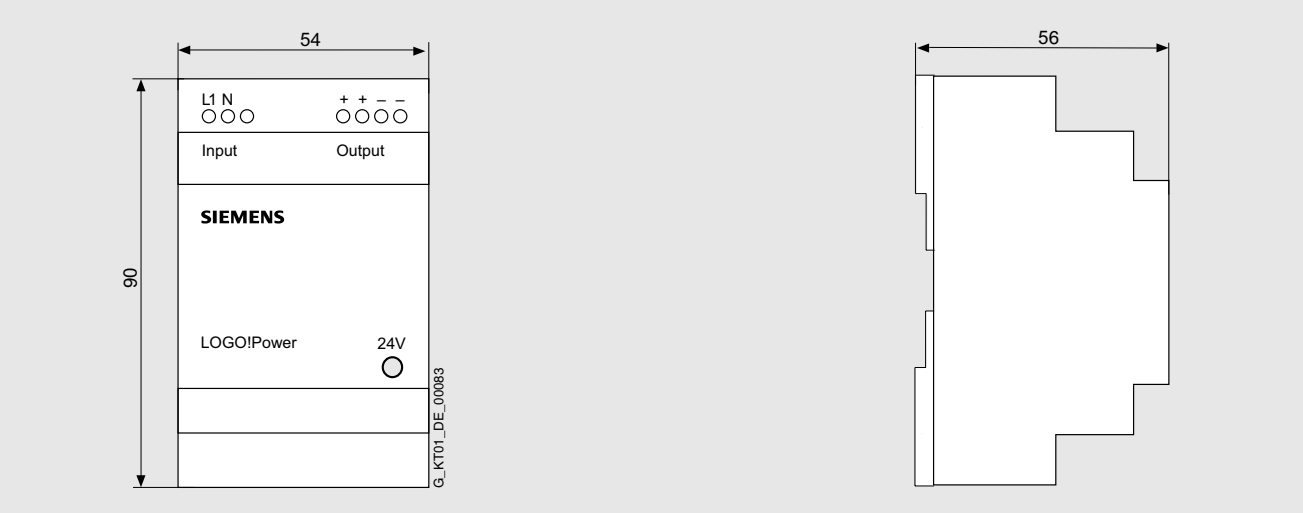

Order No.: 6EP1 332-1SH51

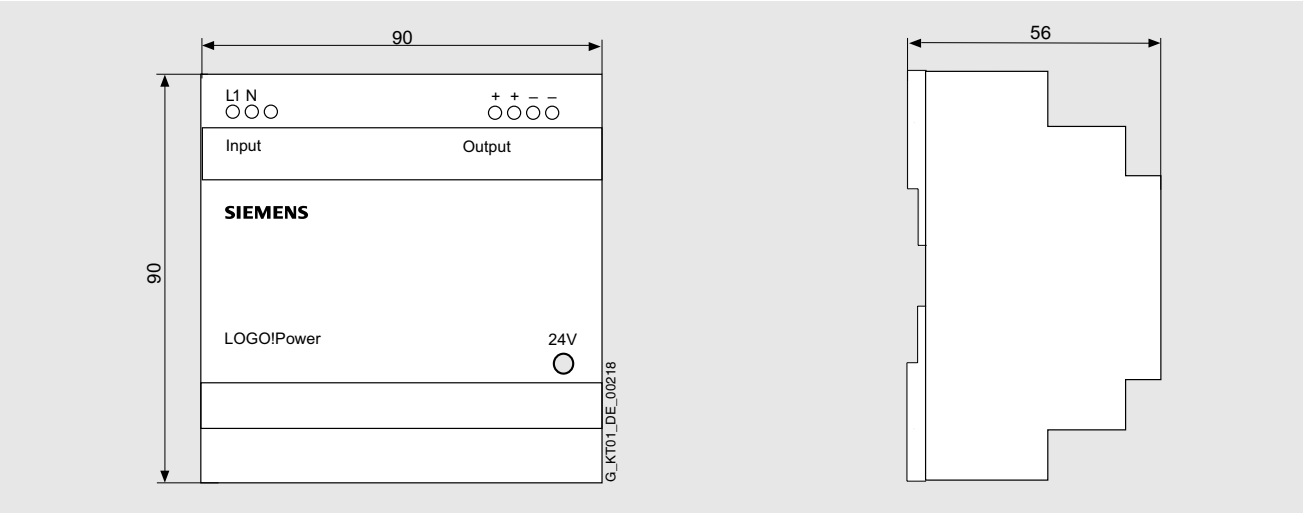

Dimension drawings

Notes





16/2	SITOP contact persons
16/7	Siemens contacts worldwide
16/8	Service & Support Information and Ordering in the Internet and on CD-ROM
16/9	Indexes
16/9	Order No. index
16/10	Subject index
16/11	Customer Support
16/14	Conditions of sale and delivery



Appendix

SITOP contact persons

in Europe

Austria

Bregenz

Siemens AG
Mr. Madlener
Josef-Huter-Str. 6
6901 Bregenz
Tel +43 (0) 51 707 682
Fax +43 (0) 51 707 522
Email guenter.madlener@siemens.at

Graz

Siemens AG
Mr. Kröll
Straßganger Str. 315
8054 Graz
Tel +43 (0) 51 707 639 22
Fax +43 (0) 51 707 586 72
Email josef.kroell@siemens.at

Innsbruck

Siemens AG
Mr. Hampel
Siemensstr. 24
6063 Rum bei Innsbruck
Tel +43 (0) 51 707 642 98
Fax +43 (0) 51 707 549 25
Email johann-georg.hampel@siemens.at

Klagenfurt

Siemens AG
Mr. Weber
Werner v. Siemens Park 1
9020 Klagenfurt
Tel +43 (0) 51 707 642 43
Fax +43 (0) 51 707 544 18
Email richard.r.weber@siemens.at

Linz

Siemens AG
Mr. Schmidt
Wolfgang-Pauli-Str. 2
4020 Linz
Tel +43 (0) 51 707 652 95
Fax +43 (0) 51 707 596 01
Email erich.e.schmidt@siemens.at

Salzburg

Siemens AG
Mr. Mariacher
Innsbrucker-Bundesstr. 35
5020 Salzburg
Tel +43 (0) 51 707 663 50
Fax +43 (0) 51 707 532 29
Email josef.mariacher@siemens.at

Vienna

Siemens AG
Mr. Strasser
Siemensstr. 88-92
1210 Wien
Tel +43 (0) 51 707 237 88
Fax +43 (0) 51 707 539 40
Email josef.strasser@siemens.at

Belarus

Minsk

Siemens
Mr. Göbecke
Ul. Y. Kupaly 25, Off. 304
220030 Minsk
Tel +375 (17) 210 03 96
Fax +375 (17) 210 03 95
Email alexander.goebcke@siemens.com

Belgium

Huizingen

Mr. De Coninck
Predslawinka Str. 11-13
3150 Kiew
Tel +32 (2) 536 95 39
Fax +32 (2) 536 23 87
Email geert.de-coninck@siemens.be

Bosnia-Herzegovina

Sarajevo

Siemens d.o.o.
Mr. Ganic
Dubrovacka 6
71000 Sarajevo
Tel +387 (33) 27 66 41
Fax +387 (33) 27 66 12 79
Email sadudin.ganic@siemens.ba

Bulgaria

Sofia

Siemens
Mrs. Boykova
Nikola Vapzarov Boulevard
1407 Sofia
Tel +359 (2) 965 96 24
Fax +359 (2) 965 96 62
Email simatic.service@siemens.bg

Croatia

Zagreb

Mrs. Ilic
Heinzelova 70a
10000 Zagreb
Tel +385 (1) 6105 337
Fax +385 (1) 6105 621
Email ivana.ilic@siemens.com

Czech Republic

Brno

Siemens s.r.o.
Mr. Bocek
Technicka 15
61600 Brno
Tel +420 (5) 4119 1731
Fax +420 (5) 4119 1749
Email petr.bocek@siemens.com

Prague

Mr. Pömmel
Evropská 33a
Praha 6
Tel +420 (2) 3303 2410
Fax +420 (2) 3303 2492
Email werner.poemmerl@siemens.com

Denmark

Kopenhagen

Mr. Limkilde
Borupvang 3
2750 Ballerup
Tel +45 4477 4883
Fax +45 4477 4002
Email llk@siemens.dk

Estonia

Tallinn

AS Siemens Automation and Drives
Mr. Ristoja
Pärnu mnt. 139 c
11317 Tallinn
Tel +372 630 47 51
Fax +372 630 47 31
Email joel.ristoja@siemens.com

Finland

Helsinki

Siemens Oy Automation and Drives
Mr. Leppala
Majurinkatu 6
02600 Espoo
Tel +358 10 511 3463
Fax +358 10 511 3656
Email ari.leppala@siemens.com

France

Paris

Mr. Rouault
39-47, Boulevard Ornano
93527 Saint-Denis CEDEX 2
Tel +33 (1) 4922 9309
Fax +33 (1) 4922 3951
Email jean-marie.rouault@siemens.fr

Germany

Aachen

Siemens AG
Mr. Schauenberg
Franz-Geuer-Str. 10
50823 Köln
Tel +49 (221) 576 2536
Fax +49 (221) 576 2921
Email frank.schauenberg@siemens.com

Augsburg

Siemens AG
Mr. Greis
Richard-Strauss-Str. 76
81679 München
Tel +49 (89) 9221 3877
Fax +49 (89) 9221 1738
Email wolfgang.greis@siemens.com

Bayreuth

Siemens AG
Mr. Fiedler
Von-der-Tann-Str. 30
90439 Nürnberg
Tel +49 (911) 654 3413
Fax +49 (911) 654 3596
Email wolfram.fiedler@siemens.com

Berlin

Siemens AG
Mr. Förster
Nonnendammallee 72
13629 Berlin
Tel +49 (30) 386 32 303
Fax +49 (30) 386 32 543
Email martin.foerster@siemens.com

Bielefeld

Siemens AG
Mr. Knauth
Frankfurter Str. 3d
38112 Braunschweig
Tel +49 (531) 2712 314
Fax +49 (531) 2712 416
Email bernd.knauth@siemens.com

Braunschweig

Siemens AG
Mr. Knauth
Frankfurter Str. 3d
38112 Braunschweig
Tel +49 (531) 2712 314
Fax +49 (531) 2712 416
Email bernd.knauth@siemens.com

Bremen

Siemens AG
Mr. Kröger
Universitätsallee 16
28359 Bremen
Tel +49 (421) 364 2185
Fax +49 (421) 364 2249
Email helmut.kroeger@siemens.com

Chemnitz

Siemens AG
Mr. Förster
Nonnendammallee 72
13629 Berlin
Tel +49 (30) 386 32 303
Fax +49 (30) 386 32 543
Email martin.foerster@siemens.com

Dresden

Siemens AG
Mr. Förster
Nonnendammallee 72
13629 Berlin
Tel +49 (30) 386 32 303
Fax +49 (30) 386 32 543
Email martin.foerster@siemens.com

Düsseldorf

Siemens AG
Mr. Schauenberg
Franz-Geuer-Str. 10
50823 Köln
Tel +49 (221) 576 2536
Fax +49 (221) 576 2921
Email frank.schauenberg@siemens.com

Erfurt

Siemens AG
Mr. Förster
Nonnendammallee 72
13629 Berlin
Tel +49 (30) 386 32 303
Fax +49 (30) 386 32 543
Email martin.foerster@siemens.com

Essen

Siemens AG
Mr. Poschmann
Kruppstr. 16
45128 Essen
Tel +49 (201) 816 2148
Fax +49 (201) 816 3621
Email rolf.poschmann@siemens.com

Frankfurt

Siemens AG
Mr. Wulle
Dynamostr. 4
68165 Mannheim
Tel +49 (621) 465 2661
Fax +49 (621) 465 2747
Email thomas.wulle@siemens.com

Freiburg

Siemens AG
Mr. Röder
Weissacher Str. 11
70499 Stuttgart
Tel +49 (711) 137 4059
Fax +49 (711) 137 2070
Email bernd.roeder@siemens.com

in Europe (continued)

Hamburg

Siemens AG
Mr. Kröger
Universitätsallee 16
28359 Bremen
Tel +49 (421) 364 2185
Fax +49 (421) 364 2249
Email helmut.kroeger
@siemens.com

Hannover

Siemens AG
Mr. Knauth
Frankfurter Str. 3d
38112 Braunschweig
Tel +49 (531) 2712 314
Fax +49 (531) 2712 416
Email bernd.knauth
@siemens.com

Heilbronn

Siemens AG
Mr. Röder
Weissacher Str. 11
70499 Stuttgart
Tel +49 (711) 137-4059
Fax +49 (711) 137-2070
Email bernd.roeder
@siemens.com

Karlsruhe

Siemens AG
Mr. Wulle
Dynamostr. 4
68165 Mannheim
Tel +49 (621) 465 2661
Fax +49 (621) 465 2747
Email thomas.wulle
@siemens.com

Kassel

Siemens AG
Mr. Knauth
Frankfurter Str. 3d
38112 Braunschweig
Tel +49 (531) 2712 314
Fax +49 (531) 2712 416
Email bernd.knauth
@siemens.com

Kempten

Siemens AG
Mr. Greis
Richard-Strauss-Str. 76
81679 München
Tel +49 (89) 9221 3877
Fax +49 (89) 9221 1738
Email wolfgang.greis
@siemens.com

Kiel

Siemens AG
Mr. Kröger
Universitätsallee 16
28359 Bremen
Tel +49 (421) 364 2185
Fax +49 (421) 364 2249
Email helmut.kroeger
@siemens.com

Koblenz

Siemens AG
Mr. Schauenberg
Franz-Geuer-Str. 10
50823 Köln
Tel +49 (221) 576 2536
Fax +49 (221) 576 2921
Email frank.schauenberg
@siemens.com

Cologne

Siemens AG
Mr. Schauenberg
Franz-Geuer-Str. 10
50823 Köln
Tel +49 (221) 576 2536
Fax +49 (221) 576 2921
Email frank.schauenberg
@siemens.com

Konstanz

Siemens AG
Mr. Röder
Weissacher Str. 11
70499 Stuttgart
Tel +49 (711) 137 4059
Fax +49 (711) 137 2070
Email bernd.roeder
@siemens.com

Leipzig

Siemens AG
Mr. Förster
Nonnendammallee 72
13629 Berlin
Tel +49 (30) 386 32 303
Fax +49 (30) 386 32 543
Email martin.foerster
@siemens.com

Magdeburg

Siemens AG
Mr. Knauth
Frankfurter Str. 3d
38112 Braunschweig
Tel +49 (531) 2712 314
Fax +49 (531) 2712 416
Email bernd.knauth
@siemens.com

Mannheim

Siemens AG
Mr. Wulle
Dynamostr. 4
68165 Mannheim
Tel +49 (621) 465 2661
Fax +49 (621) 465 2747
Email thomas.wulle
@siemens.com

Munich

Siemens AG
Mr. Greis
Richard-Strauss-Str. 76
81679 München
Tel +49 (89) 9221 3877
Fax +49 (89) 9221 1738
Email wolfgang.greis
@siemens.com

Münster

Siemens AG
Mr. Poschmann
Kruppstr. 16
45128 Essen
Tel +49 (201) 816 2148
Fax +49 (201) 816 3621
Email rolf.poschmann
@siemens.com

Nürnberg

Siemens AG
Mr. Fiedler
Von-der-Tann-Str. 30
90439 Nürnberg
Tel +49 (911) 654 3413
Fax +49 (911) 654 3596
Email wolfram.fiedler
@siemens.com

Osnabrück

Siemens AG
Mr. Poschmann
Kruppstr. 16
45128 Essen
Tel +49 (201) 816 2148
Fax +49 (201) 816 3621
Email rolf.poschmann
@siemens.com

Regensburg

Siemens AG
Mr. Fiedler
Von-der-Tann-Str. 30
90439 Nürnberg
Tel +49 (911) 654 3413
Fax +49 (911) 654 3596
Email wolfram.fiedler
@siemens.com

Rostock

Siemens AG
Mr. Kröger
Universitätsallee 16
28359 Bremen
Tel +49 (421) 364 2185
Fax +49 (421) 364 2249
Email helmut.kroeger
@siemens.com

Saarbrücken

Siemens AG
Mr. Wulle
Dynamostr. 4
68165 Mannheim
Tel +49 (621) 465 2661
Fax +49 (621) 465 2747
Email thomas.wulle
@siemens.com

Siegen

Siemens AG
Mr. Schauenberg
Franz-Geuer-Str. 10
50823 Köln
Tel +49 (221) 576 2536
Fax +49 (221) 576 2921
Email frank.schauenberg
@siemens.com

Stuttgart

Siemens AG
Mr. Röder
Weissacher Str. 11
70499 Stuttgart
Tel +49 (711) 137 4059
Fax +49 (711) 137 2070
Email bernd.roeder
@siemens.com

Trier

Siemens AG
Mr. Wulle
Dynamostr. 4
68165 Mannheim
Tel +49 (621) 465 2661
Fax +49 (621) 465 2747
Email thomas.wulle
@siemens.com

Ulm

Siemens AG
Mr. Röder
Weissacher Str. 11
70499 Stuttgart
Tel +49 (711) 137 4059
Fax +49 (711) 137 2070
Email bernd.roeder
@siemens.com

Weingarten

Siemens AG
Mr. Röder
Weissacher Str. 11
70499 Stuttgart
Tel +49 (711) 137 4059
Fax +49 (711) 137 2070
Email bernd.roeder
@siemens.com

Wetzlar

Siemens AG
Mr. Wulle
Dynamostr. 4
68165 Mannheim
Tel +49 (621) 465 2661
Fax +49 (621) 465 2747
Email thomas.wulle
@siemens.com

Würzburg

Siemens AG
Mr. Fiedler
Von-der-Tann-Str. 30
90439 Nürnberg
Tel +49 (911) 654 3413
Fax +49 (911) 654 3596
Email wolfram.fiedler
@siemens.com

Wuppertal

Siemens AG
Mr. Poschmann
Kruppstr. 16
45128 Essen
Tel +49 (201) 816 2148
Fax +49 (201) 816 3621
Email rolf.poschmann
@siemens.com

Great Britain

Manchester

Mr. Mackrory
Sir William Siemens House/
Princess Road
Manchester M20 2UR
Tel +44 (161) 446 6400
Fax +44 (161) 446 6201
Email john.mackrory
@siemens.com

Greece

Athens

Siemens A.E.
Mrs. Antoniou
Artemidos 8
15110 Amaroussio/Athen
Tel +30 (1) 6864 534
Fax +30 (1) 6864 299
Email konstantina.antonou
@siemens.gr

Hungary

Budapest

Mr. Solt
Gizella ut 51-57
1143 Budapest
Tel +36 (1) 471 1717
Fax +36 (1) 471 1704
Email attila.solt@siemens.hu

Ireland

Dublin

Siemens Ltd.
Mr. Feeley
Leeson Close
2 Dublin
Tel +353 (1) 216 2441
Fax +353 (1) 216 2499
Email martin.feeley
@siemens.com

Appendix

SITOP contact persons

in Europe (continued)

Italy

Bari

Mr. Gabellone
Via Lucarelli, 10/b
70124 Bari
Tel +39 (080) 50 24068
Email luca.gabellone@siemens.it

Bologna

Mr. Tosatti
Via del Gomito, 1
40127 Bologna
Tel +39 (051) 63 84509
Email davide.tosatti@siemens.it

Bologna

Mr. Forghieri
Via del Gomito, 1
40127 Bologna
Tel +39 (051) 63 84608
Email mauro.forghieri@siemens.it

Florence

Mr. Vessio
Via Odorico da Pordenone, 26
50127 Firenze
Tel +39 (055) 3392 201
Email domenico.vessio@siemens.it

Milan

Mr. Bischetti
Viale Piero e Alberto Pirelli 10
20126 Milano
Tel +39 (02) 6676 3321
Fax armando.bischetti@siemens.it

Milan

Mr. Berti
Viale Piero e Alberto Pirelli 10
20126 Milano
Tel +39 (02) 6676 2836
Email gualtiero.ber ti@siemens.it

Milan

Mr. Gaspari
Viale Piero e Alberto Pirelli 10
20126 Milano
Tel +39 (02) 6676 2067
Email adolfo.gaspari@siemens.it

Naples

Mr. De Sio
Via G. Quagliariello, 35/E
80146 Napoli
Tel +39 (081) 5454237
Email maurizio.desio@siemens.it

Padova

Mr. Millevoi
Viale dell'Industria, 19
35129 Padova
Tel +39 (049) 8291336
Email piero.millevoi@siemens.it

Padova

Mr. Maffioli
Viale dell'Industria, 19
35129 Padova
Tel +39 (049) 8291359
Email andrea.maffioli@siemens.it

Rome

Mr. D Innocenti
Via Laurentina 455
142 Roma
Tel +39 (06) 59692 285
Email dario.dinnocenti@siemens.it

Torino

Mr. Montoli
Via Pio VII, 127
10127 Torino
Tel +39 (011) 6173 275
Email daniele.montoli@siemens.it

Latvia

Riga

Siemens SIA
Mr. Tumpelis
Vilandes iela 3
1010 Riga
Tel +371 (701) 55 18
Fax +371 (701) 55 01
Email ugis.tumpelis@siemens.com

Lithuania

Vilnius

Siemens UAB
Mr. Laurinaitis
V. Kudirkos g.6
2009 Vilnius
Tel +370 (2) 39 1515
Fax +370 (2) 39 1501
Email rimas.laurinaitis@siemens.com

Luxembourg

Luxembourg

Siemens S.A.
Mr. Koch
20, rue des Peupliers
2328 Luxembourg-Hamm
Tel +352 (43) 8 43-403
Fax +352 (43) 8 43-449
Email edmond.koch@siemens.lu

Netherlands

The Hague

Siemens Nederland N.V.
Mr. Nieuwstraten
Prinses Beatrixlaan 800
2595 BN The Hague
Tel +31 70 333 32 74
Fax +31 70 333 38 85
Email anton.nieuwstraten@siemens.nl

Norway

Oslo

Mr. Otterstad
Østre Aker vei 90
0518 Oslo
Tel +47 2263 4164
Fax +47 2263 3390
Email dag.otterstad@siemens.no

Poland

Gdansk Sales North

Siemens Sp.z o.o.
Mr. Skicki
ul. Batorego 28-32
Gdansk Sales North
Tel +48 (58) 785 8490
Fax +48 (58) 785 8499
Email andrzej.skicki@siemens.com

Katowice Sales South

Siemens Sp.z o.o.
Mr. Mezydło
ul. Dolnych Walow 7
Katowice Sales South
Tel +48 (32) 208 4130
Fax +48 (32) 208 4139
Email tomasz.mezydlo@siemens.com

Poznan Sales West

Siemens Sp.z o.o.
Mr. Kaysiewicz
ul. Romana Maya 1
Poznan Sales West
Tel +48 (61) 650 2823
Fax +48 (61) 650 2824
Email maciej.kaysiewicz@siemens.com

Warsaw Sales East

Siemens Sp.z o.o.
Mr. Zielinski
ul. Zupnicza 11
Warszawa Sales East
Tel +48 (22) 870 9862
Fax +48 (22) 870 9119
Email andrzej.zielinski@siemens.pl

Warsaw

Siemens Sp.z o.o.
Mr. Ciuk
ul. Zupnicza 11
3821 Warszawa
Tel +48 (22) 870 9145
Fax +48 (22) 870 9169
Email andrzej.ciuk@siemens.com

Portugal

Amadora

Siemens S. A.
Mr. Filipe
Rua Irmãos de Siemens, 1
2720093 Amadora
Tel +351 (21) 417 8838
Fax +351 (21) 417 8050
Email sergio.filipe@lis1.siemens.pt

Romania

Bukarest

Siemens S.R.L.
Mr. Razvan
Calea Pleavei Nr. 139,
Corp C, sector 6
RO 77131 Bucuresti
Tel +40 2120 77 469
Fax +40 2120 77 462
Email razvan.ioachim@siemens.com

Russia

Moscow

Mr. Iwanow
Ul. Malaja Kaluzhskaja, 17/19
117071 Moscow
Tel +7 (095) 737 2492
Fax +7 (095) 737 2483
Email pawel.iwanow@siemens.com

Slovakia

Bratislava

Siemens s.r.o.
Mr. Patoprsty
Stromova 9
83796 Bratislava
Tel +421 (2) 5968-2426
Fax +421 (2) 5968 5240
Email radomir.patoprsty@siemens.sk

Slovenia

Ljubljana

Siemens d.o.o.
Mr. Mlinsek
Dunajska 22
1511 Ljubljana
Tel +386 (1) 4746-152
Fax +386 (1) 4746-138
Email matjaz.mlinsek@siemens.si

Spain

Madrid

Mr. Ramón Romero
Ronda de Europa, 5
Tres Cantos (Madrid)
Tel +34 (91) 514 4761
Fax +34 (91) 514 7019
Email pssitop@ssa.siemens.es

Sweden

Stockholm

Siemens AB
Mr. Naglitsch
Johanneslundsvägen 12-14
Upplands Väsby
Tel +46 (8) 728 1872
Fax +46 (8) 728 1290
Email peter.naglitsch@siemens.se

Switzerland

Basel

Siemens Schweiz AG
Mr. Gysin
Viaduktstr. 40
4051 Basel
Tel +41 (0) 848 822 844
Fax +41 (0) 848 822 876
Email rudolf.gysin@siemens.com

Lausanne

Siemens Suisse SA
Mr. Gysin
Avenue des Baumettes 5
1020 Renens
Tel +41 (0) 848 822 844
Fax +41 (0) 848 822 876
Email rudolf.gysin@siemens.com

Zürich

Siemens Schweiz AG
Mr. Gysin
Freilagerstr. 40
8047 Zürich
Tel +41 (0) 848 822 844
Fax +41 (0) 848 822 876
Email rudolf.gysin@siemens.com

Turkey

Istanbul

Siemens Sanayi ve Ticaret A.S.,
Istanbul
Mrs. Ynan
Yakacik Yolu No. 111
81430 Kartal-Istanbul
Tel +90 (216) 459 3706
Fax +90 (216) 459 3079
Email sevtap.inan@siemens.com.tr

in Europe (continued)

Ukraine

Kiew
Siemens AG
Mr. Fadejew
Uliza Worowskowo 27
252054 Kiew 54
Tel +380 (44) 201-2461
Fax +380 (44) 201-2466
Email wladimir.fadejew@siemens.com

Yugoslavia

Belgrade
Siemens d.o.o., Belgrad
Mr. Rajic
Knez Mihailova 30
11000 Belgrad
Tel +381 (11) 3070 184
Fax +381 (11) 3070 050
Email milan.rajic@siemens.com

outside Europe

Africa

Algeria

Algier
Siemens Algérie S.A.R.L.
Mr. Rabah Chaoui
29, rue des pins
16035 Algier
Tel +213 21 60 37 65
Tel +213 21 60 72 07
Fax +213 21 48 09 79
Email rabah.chaoui@siemens.com

Cote d'Ivoire

Abidjan
Semen
Mr. Hellal
Atelier Z.I. Vridi
Rue des Petroliers
15 B.P. 1062
Abidjan 15, Semen
Tel +225 21 27 16 75 (46 57)
Fax +225 21 27 10 21
Email philippehellal@avisoc

Egypt

Cairo
Siemens Ltd.
Mr. El-Bassyouni
55 A & B, El Nakhil and
El Aenab Street
Cairo - Mohandessin, NME
Tel +20 2 33 33 6 12
Fax +20 2 33 33 6 07
Email tamer.bassyouni@siemens.com

Samouha-Alexandria

Siemens Limites
Mr. Lotfy
27, Victor Emmanuel Street
Samouha-Alexandria
Tel +20 (3) 4251007
Fax +20 (3) 4251009
Email mina.lotfy@siemens.com

Kenya

Nairobi
International Energy Technik Ltd.
Mr. Pillay
P.O. Box 46215
Unit 90, The Alpha Centre
Mombasa Road
Nairobi
Tel +254 2 35 1082
Fax +254 2 35 0469
Email rajesh.pillay@iet.co.ke

Morocco

Casablanca
Siemens Marokko S.A.
Immeuble Siemens
Mr. Mostafa Bazokar
km 1 Route de Rabat Aïn-Sebâa
20250 Casablanca
Tel +212 22 66 92 59 (92 28)
Fax +212 22 34 01 51
Email mostafa.bazokar@siemens.com

South Africa

Johannesburg
Siemens SA
Control and Instrumentation
Siemens Park Midrand
Mr. Venter
300 Janadel Avenue
Halfway House 1685
Johannesburg - Südafrika
Tel +27 (011) 652 36 88
Fax +27 (011) 652 36 97
Email stephen.venter@siemens.com

Tunesia

Tuni
Faze Service
Mr. Fantar
Immeuble Nour El Bouhaira E. B.
Rue du Lac Turkana
Les Berges du Lac
1053 Tuni
Tel +216 71 964 266
Fax +216 71 964 265
Email afif.fantar@faze.com.tn

America

Argentina

Buenos Aires
Siemens S.A.
Mr. Abenante
Calle 122 (ex Gral. Roca) 4785,
Ruta 8, km 18 - Casilla de
Correo 32
RA-B1653 JXA San Martin
Prov. de Buenos Aires
Tel +54 11 4738 7341
Fax +54 11 4738 7271
Email matias.abenante@siemens.com

Brazil

São Paulo
Siemens Ltd.
Mr. Marchesan
Rua Coronel Bento Bicudo,
111 - Lapa
05069 900 São Paulo - SP
Tel +55 11 3833 4115
Fax +55 11 3833 4183
Email ricardo.marchesan@siemens.com

Canada

Ontario
Siemens Canada Ltd.
Mr. Udayan
80 Walker Drive
Brampton, ON L6T 4H6
Tel +1 905 819 5800 (2470)
Fax +1 905 819 5719
Email udayan.pandya@siemens.com

Chile

Santiago de Chile
Siemens SA Mercosur
Mr. Gorenberg
Alameda 194, p°3 - Santiago
Santiago de Chile
Tel +56 2 361 4283
Fax +56 2 361 4293
Email andres.gorenberg@siemens.com

Columbia

Santafé de Bogotá D.C.
Siemens S.A.
Mr. Mejia
Carrera 65 No. 11-83
Santafé de Bogotá D.C.
Tel +57 (1) 4253 710
Fax +57 (1) 2942 600
Email jorge.mejia@siemens.com

Costa Rica

San José
Siemens S.A. San José
Mr. Blanco
La Uruca
Apartado: 10022-1000 S.J.
San José, Costa Rica
Tel +506 (287) 5251
Fax +506 (287) 5295
Email sergio.blanco@siemens.com.mx

El Salvador

San Salvador
Mr. Callejas
Antiguo Cuscatlán,
Apartado 1525
01 137 San Salvador
Tel +503 278 3333
Fax +503 278 3334
Email victor.callejas@siemens.com

Guatemala

Ciudad de Guatemala
Siemens S.A.
Mr. Godoy
2a. Calle 6-76, Zona 10
Ciudad de Guatemala
Tel +502 379 2333
Fax +502 379 2318
Email miguel.godoy@siemens.com

Mexico

Colonial Industrial Vallejo
Siemens SA
Mr. Quintana
Poniente 116 No. 560
02300 México, D.F.
Tel +525 55 328 20 00 - 3330
Fax +525 55 328 20 00 - 2097
Email edgar.quintana@siemens.com

Colonial Industrial Vallejo

Siemens SA
Mr. Sánchez
Poniente 116 No. 560
Colonial Industrial Vallejo
Tel +52 (5) 328-2112
Fax +52 (5) 328-2097
Email gregorio.sanchez@siemens.com

Peru

Lima
Siemens
Mr. Balarezo
Av. Domingo Orué 971, Surquillo
Lima
Tel +51 (1) 2150030 (4354)
Fax +51 (1) 42 19 292
Email jesus.balarezo@siemens.com

USA

Norcross
Siemens SE&A
Mr. Bronzel
5300 Triangle Parkway
30092-2538 Norcross, GA
Tel +001 (770) 871 3946
Fax +001 (770) 871 3996
Email kai-uwe.bronzel@siemens.com

Venezuela

Caracas
Siemens s.a.
Mr. Cavada
Av. Don Diego Disneros
(1010-A-Aptdo. 3616) =Pf
Urbanización, Los Ruices
Caracas 1071
Tel +58 (2) 203 8436
Fax +58 (2) 203 8523
Email jesus.cavada@siemens.com

Appendix

SITOP contact persons

outside Europe (continued)

Asia

China

Beijing

Siemens Limited
Mr. Shi
7, Wangjing Zhonghuan Nanlu
100015 Beijing
Tel +86 (10) 6472 1888 (3374)
Fax +86 (10) 6473 9213
Email lin.shi@siemens.com

Beijing

Siemens Limited
Mr. Deng
7, Wangjing Zhonghuan Nanlu
100015 Beijing
Tel +86 (10) 6472 1888 (3903)
Fax +86 (10) 6473 9213
Email xu.deng@siemens.com

Hong Kong

Siemens Ltd.
Mr. Lam
58/F, Central Plaza,
18 Harbour Road
Wanchai, Hong Kong
Tel +86 (852) 2583 3228
Fax +86 (852) 2824 9196
Email jacky.lam@siemens.com

India

Thane

Siemens Limited
Mr. Karmile
Kalwa Works, Thane Belapur
Road
400 601 Thane (Maharashtra)

Indonesia

Jakarta

P.T. Siemens Indonesia
Mr. Ansori
Jalan Jendral Ahmad Yani
Kav. B 67-68
Pulo Mas
13210 Jakarta
Tel +62 (21) 4729-348
Fax +62 (21) 4729-300
Email ato.ansori@siemens.com

Iran

Theran

Siemens Sherkate Sahami (Khas)
Mr. Jashni
Avenue Ayatollah Taleghani 32
15936 Theran
Tel +9821 6142234
Fax +9821 6460615
Email yousef.jashni@siemens.com

Israel

Tel-Aviv

ARDAN
Production & Industrial
Control Ltd.
Mr. Bauer
32, Habanay Street
Holon 58856
Tel +972 (3) 6 50 70 00
Fax +972 (3) 5 58 13 11
Email bauer@ardan-pic.co.il

Japan

Shinagawa-ku, Tokyo

Siemens K.K.
Mr. Ishida
20-14, Higashi-Gotanda 3-
chome
141-8614 Shinagawa-ku, Tokyo
Tel +81 (3) 5423 8594
Fax +81 (3) 5423 8734
Email toshikazu.ishida@siemens.com

Jordan

Amman

F.A. Kettaneh & Co.Ltd.
Mr. Rami
Al Quds Street, P.O. Box 485
11118 Amman
Tel +962 (6) 439 8642/7173
Fax +962 (6) 439 2582
Email al-naqa.rami@kettaneh.com.jo

Lebanon

Mar-Mikhael-Beirut

Kettaneh S.A.
Mr. Markarian
Nahr Street
Mar-Mikhael- Beirut
Tel 00961 1 444560/3
Fax 00961 1 4446284
Email avedis.markarian@kettaneh.com

Kazakhstan

Almaty

Siemens TOO
Mr. Kokoulin
20, Zharokov St.
480008 Almaty
Tel +73 272 597 828
Fax +73 272 583 700
Email andrej.kokoulin@siemens.com

Kuwait

Sharq

Siemens
Mr. Chhabra
Jaber Al-Mubarak Street, Block 4
Sharq, Kuwait
Tel 965 241 8888
Fax 965 246 3222
Email naukhez.arслан@siemens.com

Korea

Seoul

Siemens Limited
Mr. Song
726, Asia Building 10th floor
Yeoksam-dong, Kangnam-gu
135 925 Seoul
Tel +82 (2) 3420 4897
Fax +82 (2) 527 7785
Email songss@siemens.com

Malaysia

Kuala Lumpur

Mrs. Leong
11 section 16/11,
Jalan Damansara
46350 Petaling Jaya,
Selangor Darul Ehsan
Tel +60 (3) 7952 5363
Fax +60 (3) 7955 2282
Email therese.leong@siemens.com

Pakistan

Karachi

Siemens Pakistan
Engineering Co. Ltd.
Mr. Naukhez
B-72, Estate Avenue, S.I.T.E.
75700 Karachi
Tel +92 (21) 2574 910 19-4387
Fax +92 (21) 256 3563
Email naukhez.arслан@siemens.com

Philippines

Makati City

Siemens Inc.
Mr. Salud
169 H.V. De la Costa Street,
Salcedo Village
1227 Makati City
Tel +63 (2) 814 9678
Fax +63 (2) 814 9894
Email bernard.salud@siemens.com

Saudi Arabia

Jeddah

Siemens Ltd.
Mr. Vhora
Baladia/Binzager Street
Jeddah 21412
Tel +966 (2) 661-4444 (2069)
Fax +966 (2) 661-4444 (1500)
Email abdulhafiz.vhora@siemens.com

Thailand

Bangkok

Siemens
Mr. Somchai
2922/283 New Petchburi Road,
Bangkapi, Huay Kwang
10310 Bangkok
Tel +66 2715 4850
Fax +66 2715 4841
Email somchaj@siemens.com

Taiwan

Taipei

Siemens
Mr. Gu
3, Yuan Qu Street,
Nan Gang District
115 Taipei
Tel +886 (2) 2652 8888
Fax +886 (2) 2652 8948
Email ginfu.gu@siemens.com

Uzbekistan

Taschkent

Siemens AG
Mr. Dobrev
K. Yarmatov Str. 6
Taschkent
Tel +998 (71) 120 6403
Fax +998 (71) 120 6402
Email evgeniy.dobrev@siemens.com

Vietnam

Hanoi

Siemens AG
Mr. Phuong
239 Xuan Thuy Road,
Cau Giay District
Hanoi
Tel +84 (4) 8334 400
Fax +84 (4) 8334 371
Email nguyen-ngoc.phuong@siemens.com

Australia

Bayswater Victoria

Siemens Limited
Mr. Avellino
885 Mountain Highway
3153 Bayswater Victoria
Tel +61 3 9721 7592
Fax +61 3 9721 7630
Email mark.avellino@siemens.com

Further information on contact person's addresses can be found in the Internet under <http://www.siemens.com/automation/partner>

Appendix Siemens contacts worldwide



At

www.siemens.com/automation/partner

you can find details of Siemens contact partners worldwide responsible for particular technologies.

You can obtain in most cases a contact partner for

- Technical Support,
- Spare parts/repairs,
- Service,
- Training,
- Sales or
- Consultation/engineering.

You start by selecting a

- Country,
- Product or
- Sector.

By further specifying the remaining criteria you will find exactly the right contact partner with his/her respective expertise.

Appendix Service & Support

Information and Ordering in the Internet and on CD-ROM

A&D in the WWW



A detailed knowledge of the range of products and services available is essential when planning and configuring automation systems. It goes without saying that this information must always be fully up-to-date.

The Siemens Automation and Drives Group (A&D) has therefore built up a comprehensive range of information in the World Wide Web, which offers quick and easy access to all data required.

Under the address

<http://www.siemens.com/automation>

you will find everything you need to know about products, systems and services.

Product Selection Using the Interactive Catalog



Detailed information together with convenient interactive functions:

The interactive catalog CA 01 covers more than 80,000 products and thus provides a full summary of the Siemens Automation and Drives product base.

Here you will find everything that you need to solve tasks in the fields of automation, switchgear, installation and drives.

All information is linked into a user interface which is easy to work with and intuitive.

After selecting the product of your choice you can order at the press of a button, by fax or by online link.

Information on the interactive catalog CA 01 can be found in the Internet under

<http://www.siemens.com/automation/ca01>

or on CD-ROM or DVD.

Easy Shopping with the A&D Mall



The A&D Mall is the virtual department store of Siemens AG in the Internet. Here you have access to a huge range of products presented in electronic catalogs in an informative and attractive way.

Data transfer via EDIFACT allows the whole procedure from selection through ordering to tracking of the order to be carried out online via the Internet.

Numerous functions are available to support you.

For example, powerful search functions make it easy to find the required products, which can be immediately checked for availability. Customer-specific discounts and preparation of quotes can be carried out online as well as order tracking and tracing.

Please visit the A&D Mall on the Internet under:

<http://www.siemens.com/automation/mall>

Order No. index

Type	Page	Type	Page
5SY4		6EP1	
5SY4...	14/16	6EP1 935-6MF01	9/18, 15/12
6EP1		6EP1 961-2BA00	8/4, 15/9
6EP1 311-1SH02	13/2, 15/15	6EP1 961-3BA00	8/2, 15/9
6EP1 311-1SH12	13/2, 15/15	6EP1 961-3BA10	8/2, 15/9
6EP1 321-1SH02	13/4, 15/15	6EP1 961-3BA20	8/2, 15/9
6EP1 322-1SH02	13/4, 15/15	6EP1 971-1AA01	8/6, 15/10
6EP1 331-1SH02	13/8, 15/15	6EP1 971-2BA00	8/6, 15/10
6EP1 331-1SL11	2/3, 15/2	6ES7	
6EP1 331-2BA00	2/2, 15/2	6ES7 305-1BA80-0AA0	2/3, 15/3
6EP1 331-2BA10	2/2, 15/2	6ES7 307-1KA01-0AA	5/3, 15/5
6EP1 332-1SH12	3/2, 15/3	6ES7 307-1BA00-0AA0	2/3, 15/2
6EP1 332-1SH22	3/2, 15/3	6ES7 307-1EA00-0AA0	4/3, 15/3
6EP1 332-1SH31	3/2, 15/3	6ES7 307-1EA80-0AA0	4/3, 15/3
6EP1 332-1SH42	13/8, 15/15	8AW1	
6EP1 332-1SH51	13/8, 15/15	8AW1 011...	14/17
6EP1 333-1AL12	4/3, 15/4		
6EP1 333-1SL11	4/3, 15/3		
6EP1 333-2AA00	4/2, 14/18, 15/4		
6EP1 333-2BA00	4/2, 14/18, 15/4		
6EP1 333-3BA00	4/2, 7/2, 14/19, 15/4		
6EP1 334-1AL12	5/3, 15/4		
6EP1 334-1SH01	5/3, 15/5		
6EP1 334-1SL12	5/3, 15/5		
6EP1 334-2AA00	5/2, 14/18, 15/5		
6EP1 334-2BA00	5/2, 14/18, 15/5		
6EP1 334-2CA00	5/3, 15/5		
6EP1 334-3BA00	5/2, 7/2, 14/19, 15/5		
6EP1 336-2BA00	6/3, 15/8		
6EP1 336-3BA00	6/2, 15/7		
6EP1 337-3BA00	6/2, 15/7		
6EP1 351-1SH02	13/6, 15/15		
6EP1 352-1SH02	13/6, 15/15		
6EP1 353-0AA00	10/2, 15/13		
6EP1 353-2BA00	10/2, 15/13		
6EP1 354-1AL01	11/2, 15/14		
6EP1 434-2BA00	7/6, 15/8		
6EP1 436-2BA00	7/6, 14/20, 15/8		
6EP1 436-3BA00	7/3, 14/21, 15/7		
6EP1 437-2BA00	7/7, 14/20, 15/8		
6EP1 437-2BA10	7/7, 15/8		
6EP1 437-3BA00	7/3, 14/21, 15/7		
6EP1 457-3BA00	10/2, 15/13		
6EP1 536-2AA00	6/3, 15/8		
6EP1 632-1AL01	11/2, 15/14		
6EP1 731-2BA00	2/2, 15/2		
6EP1 732-0AA00	2/3, 15/3		
6EP1 931-2DC21	9/7, 15/11		
6EP1 931-2DC31	9/7, 15/11		
6EP1 931-2DC41	9/7, 15/11		
6EP1 931-2EC21	9/9, 15/11		
6EP1 931-2EC31	9/9, 15/11		
6EP1 931-2EC41	9/9, 15/11		
6EP1 931-2FC01	9/13, 15/11		
6EP1 935-6MC01	9/14		
6EP1 935-6MD11	9/16, 15/12		
6EP1 935-6MD31	9/15, 15/12		
6EP1 935-6ME21	9/17, 15/12		

Appendix

Indexes

Subject index

A		O	
A&D online services	16/8	Overview of product families	1/6
Alternative voltages	10/2	P	
AS interface power supplies	11/2	Parallel connection for redundant operation and performance enhancement	14/12
B		Planning aids	14/11
Battery charging	14/15	Possible system disturbances and causes	14/9
Battery module 1.2 Ah	9/14	Power supplies, single-phase	2/2, 3/2
Battery module 12 Ah	9/18	Power supplies, single- and two-phase	4/2, 5/2, 6/2
Battery module 2.5 Ah	9/15	Power supplies, three-phase	7/2
Battery module 3.2 Ah	9/16	S	
Battery module 7 Ah	9/17	Selection guide	1/9
C		Series connection to increase the voltage	14/14
Conditions of sale and delivery	16/14	SITOP modular buffer module	8/2
Contact persons	16/2	SITOP modular redundancy module	8/2
D		SITOP modular signalling module	8/2
DC UPS module 15 A	9/3	SITOP select	8/4
DC UPS module 40 A	9/11	Specification sheet for customized power supplies	12/3
DC UPS module 6 A	9/3	Stabilized DC power supplies	14/2
DC UPS software	9/2	T	
Dimension drawings	section 15	Totally Integrated Automation – innovations for more productivity	1/4
F		U	
Fusing of the output circuit, selectivity	14/15	Uninterruptible power supplies	9/2
L			
Line-side connection	14/5		
LOGO!Power	13/2		
M			
Mains specifications	14/5		
Mounting	14/10		
Mounting areas and fixing options	14/10		

Our Services for Every Phase of Your Project



In the face of harsh competition you need optimum conditions to keep ahead all the time: A strong starting position. A sophisticated strategy and team for the necessary support - in every phase. Service & Support from Siemens provides this support with a complete range of different services for automation and drives.

In every phase: from planning and startup to maintenance and upgrading.

Our specialists know when and where to act to keep the productivity and cost-effectiveness of your system running in top form.

Online Support



The comprehensive information system available round the clock via Internet ranging from Product Support and Service & Support services to Support Tools in the Shop.

<http://www.siemens.com/automation/service&support>

Technical Support



Competent consulting in technical questions covering a wide range of customer-oriented services for all our products and systems.

Tel.: +49 (0)180 50 50 222
Fax: +49 (0)180 50 50 223
E-Mail: adsupport@siemens.com

Technical Consulting



Support in the planning and designing of your project from detailed actual-state analysis, target definition and consulting on product and system questions right to the creation of the automation solution. ¹⁾

Configuration and Software Engineering



Support in configuring and developing with customer-oriented services from actual configuration to implementation of the automation project. ¹⁾

Service On Site



With Service On Site we offer services for startup and maintenance, essential for ensuring system availability.

In Germany
0180 50 50 444 ¹⁾

Repairs and Spare Parts



In the operating phase of a machine or automation system we provide a comprehensive repair and spare parts service ensuring the highest degree of operating safety and reliability.

In Germany
0180 50 50 448 ¹⁾

Optimization and Upgrading



To enhance productivity and save costs in your project we offer high-quality services in optimization and upgrading. ¹⁾

¹⁾ For country-specific telephone numbers go to our Internet site at: <http://www.siemens.com/automation/service&support>

Appendix Customer Support

Knowledge Base on CD-ROM



For locations without online connections to the Internet there are excerpts of the free part of the information sources available on CD-ROM (Service & Support Knowledge Base). This CD-ROM contains all the latest product information at the time of production (FAQs, Downloads, Tips and Tricks, Updates) as well as general information on Service and Technical Support.

The CD-ROM also includes a full-text search and our Knowledge Manager for targeted searches for solutions. The CD-ROM will be updated every 4 months.

Just the same as our online offer in the Internet, the Service & Support Knowledge Base on CD comes complete in 5 languages (German, English, French, Italian, Spanish).

You can order the **Service & Support Knowledge Base** CD from your Siemens contact.

Order no. **6ZB5310-0EP30-0BA2**

Orders via the Internet (with Automation Value Card or credit card) at:

<http://www.siemens.com/automation/service&support>

in the Shop domain.

Automation Value Card



Small card - great support

The Automation Value Card is an integral component of the comprehensive service concept with which Siemens Automation and Drives will accompany you in each phase of your automation project.

It doesn't matter whether you want just specific services from our Technical Support or want to purchase high-quality Support Tools in our Online Shop, you can always pay with your Automation Value Card. No invoicing, transparent and safe. With your personal card number and associated PIN you can view the state of your account and all transactions at any time.

Services on card. This is how it's done.

Card number and PIN are on the back of the Automation Value Card. When delivered, the PIN is covered by a scratch field, guaranteeing that the full credit is on the card.

By entering the card number and PIN you have full access to the Service & Support services being offered. The charge for the services procured is debited from the credits on your Automation Value Card.

All the services offered are marked in currency-neutral credits, so you can use the Automation Value Card worldwide.

Automation Value Card order numbers

Credits	Order no.
200	6ES7 997-0BA00-0XA0
500	6ES7 997-0BB00-0XA0
1000	6ES7 997-0BC00-0XA0
10000	6ES7 997-0BG00-0XA0

Detailed information on the services offered is available on our Internet site at:

<http://www.siemens.com/automation/service&support>

Service & Support à la Card: Examples

Technical Support	
"Priority"	Priority processing for urgent cases
"24 h"	Availability round the clock
„Extended“	Technical consulting for complex questions
Support Tools in the Support Shop	
"System Utilities"	Tools that can be used directly for configuration, analysis and testing
"Applications"	Complete topic solutions including ready-tested software
"Functions & Samples"	Adaptable blocks for accelerating your developments

Conditions of sale and delivery

Terms and Conditions of Sale and Delivery

By using this catalog you can acquire hardware and software products described therein from the Siemens AG subject to the following terms. Please note! The scope, the quality and the conditions for supplies and services, including software products, by any Siemens entity having a registered office outside of Germany, shall be subject exclusively to the General Terms and Conditions of the respective Siemens entity.

for customers with a seat or registered office in the Federal Republic of Germany

The General Terms of Payment as well as the General Conditions for the Supply of Products and Services of the Electrical and Electronics Industry shall apply.

For software products, the General License Conditions for Software Products for Automation and Drives for Customers with Seat or registered Office in Germany shall apply.

for customers with a seat or registered office outside of Germany

The General Terms of Payment as well as the General Conditions for Supplies of Siemens, Automation and Drives for Customers with a Seat or registered Office outside of Germany shall apply.

For software products, the General License Conditions for Software Products for Automation and Drives for Customers with Seat or registered Office outside of Germany shall apply.

General

The prices are in € (Euro) ex works, exclusive packaging.

The sales tax (value added tax) is not included in the prices. It shall be debited separately at the respective rate according to the applicable legal regulations.

In addition to the prices of products which include silver and/or copper, surcharges may be calculated if the respective limits of the notes are exceeded.

Prices are subject to change without prior notice. We will debit the prices valid at the time of delivery.

The dimensions are in mm. Illustrations are not binding.

Insofar as there are no remarks on the corresponding pages, - especially with regard to data, dimensions and weights given - these are subject to change without prior notice.

Comprehensive Terms and Conditions of Sale and Delivery are available free of charge from your local Siemens business office under the following Order Nos.:

- 6ZB5310-0KR30-0BA0
(for customers based in the Federal Republic of Germany)
- 6ZB5310-0KS53-0BA0
(for customers based outside of the Federal Republic of Germany)

or download them from the Internet:

www.siemens.com/automation/mall

(Germany: A&D Mall Online-Help System)

Export regulations

The products listed in this catalog / price list may be subject to European / German and/or US export regulations.

Therefore, any export requiring a license is subject to approval by the competent authorities.

According to current provisions, the following export regulations must be observed with respect to the products featured in this catalog / price list:

AL	Number of the <u>German Export List</u> . Products marked other than "N" require an export license. In the case of software products, the export designations of the relevant data medium must also be generally adhered to. Goods labeled with an " <u>AL not equal to N</u> " are subject to a European or German export authorization when being exported out of the EU.
ECCN	Export <u>Control Classification Number</u> . Products marked other than "N" are subject to a reexport license to specific countries. In the case of software products, the export designations of the relevant data medium must also be generally adhered to. Goods labeled with an " <u>ECCN not equal to N</u> " are subject to a US re-export authorization.

Even without a label or with an "AL: N" or "ECCN: N", authorization may be required due to the final destination and purpose for which the goods are to be used.

The deciding factors are the AL or ECCN export authorization indicated on order confirmations, delivery notes and invoices.

Errors excepted and subject to change without prior notice.

A&D/VuL/En 14.11.03

Siemens AG
Automation and Drives
Sales Power Supplies, System Cables
Postfach 23 55
90713 FÜRTH
FEDERAL REPUBLIC OF GERMANY

Order No.
E86060-K2410-A101-A5-7600
KG 1004 27.0 BD 148 En/ 522194
Printed in the Federal Republic of Germany

Catalogs of the Automation and Drives Group (A&D)

Further information can be obtained from our
branch offices listed in the appendix of this catalog

Automation and Drives	<i>Catalog</i>	Low-Voltage Controls and Distribution	<i>Catalog</i>
Interactive catalog on CD-ROM		Low-Voltage Switchgear – Controlgear for Industry	LV 10
• The Offline Mall of Automation and Drives	CA 01	Power Distribution – Products and Systems for Low-Voltage Power Distribution	LV 30
Automation Systems for Machine Tools		SIDAC-D reactors and SIDAC-F filters	LV 63
SINUMERIK & SIMODRIVE	NC 60	SIVACON 8PS Busbar Trunking Systems CD, BD01, BD2 up to 1250 A	LV 70
Drive Systems		Busbar trunking systems LDA/LDC	LV 71
<u>Variable-Speed Drives</u>		Busbar trunking systems LXA/LXC	LV 72
SINAMICS G130 Drive Converter Chassis Units	D 11	SETRON WL	NS WL
SINAMICS G150 Drive Converter Cabinet Units		Motion Control System SIMOTION	PM 10
SINAMICS G110 Inverter Chassis Units	D 11.1	Process Instrumentation and Analytics	
SINAMICS S120 Servo Control Drive System	D 21.2	Field Instruments for Process Automation	FI 01
SINAMICS S150 Drive Converter Cabinet Units	D 21.3	Measuring Instruments for Pressure, Differential Pressure, Flow, Level and Temperature, Positioners and Liquid Meters	
DC Motors	DA 12	<i>PDF: Indicators for panel mounting</i>	MP 12
SIMOREG DC MASTER 6RA70 Digital Chassis Converters	DA 21.1	SIREC Recorders and Accessories	MP 20
SIMOREG K 6RA22 Analog Chassis Converters	DA 21.2	SIPART, Controllers and Software	MP 31
SIMOREG DC MASTER 6RM70 Digital Converter Cabinet Units	DA 22	SIWAREX Weighing Systems	WT 01
SIMOVERT PM Modular Converter Systems	DA 45	Continuous Weighing and Process Protection	WT 02
SIEMOSYN Motors	DA 48	Gas Analysis Equipment for the Process Industry	PA 10
MICROMASTER 410/420/430/440 Inverters	DA 51.2	<i>PDF: Process Analytics, Components for the System Integration</i>	PA 11
MICROMASTER 411/COMBIMASTER 411	DA 51.3	SIPAN Liquid Analysis	PA 20
SIMOVERT MV Medium-Voltage Drives	DA 63	SIMATIC Industrial Automation Systems	
SIMOVERT MASTERDRIVES Vector Control	DA 65.10	SIMATIC PCS Process Control System	ST 45
SIMOVERT MASTERDRIVES Motion Control	DA 65.11	<i>PDF: SIMATIC S5/505 Automation Systems</i>	ST 50
Synchronous and asynchronous servomotors for SIMOVERT MASTERDRIVES	DA 65.3	Components for Totally Integrated Automation and Micro Automation	ST 70
SIMODRIVE 611 universal and POSMO	DA 65.4	SIMATIC PCS 7 Process Control System	ST PCS 7
<u>Low-Voltage Three-Phase-Motors</u>		<i>PDF: Add-ons for the SIMATIC PCS 7 Process Control System</i>	ST PCS 7.A
Squirrel-Cage Motors, Totally Enclosed, Fan-Cooled	M 11	SIMATIC Control Systems	ST DA
<u>Automation Systems for Machine Tools SIMODRIVE</u>	NC 60	SIPOS Electric Actuators	
• Main Spindle Motors		Electric Rotary, Linear and Part-turn Actuators	MP 35
• Feed Motors		Electric Rotary Actuators for Nuclear Plants	MP 35.1/2
• Converter Systems SIMODRIVE 611/POSMO		Systems Engineering	
<u>Drive and Control Components for Hoisting Equipment</u>	HE 1	Power supplies SITOP power	KT 10.1
Electrical Installation Technology		System cabling SIMATIC TOP connect	KT 10.2
<i>PDF: ALPHA Small Distribution Boards and Distribution Boards</i>	ET A1	System Solutions	
<i>PDF: ALPHA Side-by-Side Switchgear Cabinets</i>	ET A3	Applications and Products for Industry are part of the interactive catalog CA 01	
<i>PDF: ALPHA FIX Terminal Blocks</i>	ET A5	TELEPERM M Process Control System	
<i>PDF: BETA Modular Installation Devices</i>	ET B1	AS 235, AS 235H and AS 235K automation systems	PLT 111
<i>PDF: DELTA Switches and Outlets</i>	ET D1	<i>PDF: AS 488/TM automation systems</i>	PLT 112
<i>PDF: GAMMA Building Management Systems</i>	ET G1	Operating and monitoring with WinCC/TM	PLT 123
Factory Automation Sensors	FS 10	CS 275 bus system	PLT 130
Human Machine Interface Systems SIMATIC HMI	ST 80		
Industrial Communication for Automation and Drives	IK PI		

PDF: These catalogs are only available as pdf files.

The information provided in this catalog contains descriptions or characteristics of performance which in case of actual use do not always apply as described or which may change as a result of further development of the products. An obligation to provide the respective characteristics shall only exist if expressly agreed in terms of contract. Availability and technical specifications are subject to change without notice.

Siemens AG

Automation and Drives

Systems Engineering

Sales Power Supplies, System Cables

www.siemens.com

Order No.: E86060-K2410-A101-A5-7600